

INTRODUCTION

COURSE DESCRIPTION

There are two major branches in economics:

- Microeconomics
- Macroeconomics

MACROECONOMICS

provides a framework for the study of the determinants & movements of such key economic variables as...

- unemployment
- inflation
- interest rates
- exchange rate
- productivity and growth
- government budget deficit/surplus
- foreign trade deficit

In Macroeconomics, we study the likely response of key economic variables to such public policies as...

- fiscal policy
- monetary policy
- trade policies

OBJECTIVE

- Help you learn how the national economy works
- Enable you to understand such issues as...
 - why key economic variables are at their present levels...
 - what may be the likely future paths of these variables...
 - causes and consequences of recessions, inflation, etc.,
 - what the government can do about these problems...
 - side effects of government actions...
 - pros and cons of free trade versus trade restrictions

OUTLINE OF THIS COURSE

- Introduction
 - Scope of Macroeconomics
 - Macroeconomic data and its measurement
- The Economy in the Long Run
 - National Income
 - Economic Growth
 - Unemployment
 - Money and Inflation
 - Open Economy
- The Economy in the Short Run
 - Economic Fluctuations
 - Aggregate Demand
 - Aggregate Supply
- Govt. Debt and Budget Deficits
- Microeconomic Foundations
 - Consumption

- Investment
- Money supply and demand

Economy. . .

. . . The word *economy* comes from a Greek word for “one who manages a household.”

TEN PRINCIPLES OF ECONOMICS

- A household and an economy face many decisions:
 - Who will work?
 - What goods and how many of them should be produced?
 - What resources should be used in production?
 - At what price should the goods be sold?

Society and Scarce Resources:

- The management of society’s resources is important because resources are scarce.
- Scarcity. . . means that society has limited resources and therefore cannot produce all the goods and services people wish to have.

Economics is the study of how society manages its scarce resources.

- How people make decisions.
 - People face tradeoffs.
 - The cost of something is what you give up to get it.
 - Rational people think at the margin.
 - People respond to incentives.
- How people interact with each other.
 - Trade can make everyone better off.
 - Markets are usually a good way to organize economic activity.
 - Governments can sometimes improve economic outcomes.
- The forces and trends that affect how the economy as a whole works.
 - The standard of living depends on a country’s production.
 - Prices rise when the government prints too much money.
 - Society faces a short-run tradeoff between inflation and unemployment.

PRINCIPLE OF MACROECONOMICS

Principle #1: People Face Tradeoffs

“There is no such thing as a free lunch!”

To get one thing, we usually have to give up another thing.

- Guns v. butter
- Food v. clothing
- Leisure time v. work
- Efficiency v. equity

Making decisions requires trading off one goal against another.

- Efficiency v. Equity
 - *Efficiency* means society gets the most that it can from its scarce resources.
 - *Equity* means the benefits of those resources are distributed fairly among the members of society.

Principle #2: Cost of Something Is What You Give Up to Get It

- Decisions require comparing costs and benefits of alternatives.
 - Whether to go to college or to work?
 - Whether to study or go out on a date?
 - Whether to go to class or sleep in?
- The **opportunity cost** of an item is what you give up to obtain that item.

Principle #3: Rational People Think at the Margin

- Marginal changes are small, incremental adjustments to an existing plan of action. People make decisions by comparing costs and benefits at the margin.

Principle #4: People Respond to Incentives

- Marginal changes in costs or benefits motivate people to respond.
- The decision to choose one alternative over another occurs when that alternative's marginal benefits exceed its marginal costs!

Principle #5: Trade Can Make Everyone Better Off

- People gain from their ability to trade with one another.
- Competition results in gains from trading.
- Trade allows people to specialize in what they do best.

Principle #6: Markets are a good way to organize economic activity

- A **market economy** is an economy that allocates resources through the decentralized decisions of many firms and households as they interact in markets for goods and services.
 - Households decide what to buy and who to work for.
 - Firms decide who to hire and what to produce.
- Adam Smith made the observation that households and firms interacting in markets act as if guided by an “invisible hand.”
 - Because households and firms look at prices when deciding what to buy and sell, they unknowingly take into account the social costs of their actions.

- As a result, prices guide decision makers to reach outcomes that tend to maximize the welfare of society as a whole.

Principle #7: Governments can sometimes improve market outcomes

- **Market failure** occurs when the market fails to allocate resources efficiently.
- When the market fails (breaks down) government can intervene to promote efficiency and equity.
- Market failure may be caused by
 - an **externality**, which is the impact of one person or firm's actions on the well-being of a bystander.
 - **market power**, which is the ability of a single person or firm to unduly influence market prices.

Principle #8: The standard of living depends on a country's production

- Almost all variations in living standards are explained by differences in countries' productivities.
- **Productivity** is the amount of goods and services produced from each hour of a worker's time.
- Standard of living may be measured in different ways:
 - By comparing personal incomes.
 - By comparing the total market value of a nation's production.

Principle #9: Prices rise when the government prints too much money

- Inflation is an increase in the overall level of prices in the economy.
- One cause of inflation is the growth in the quantity of money.
- When the government creates large quantities of money, the value of the money falls.

Principle #10: Society Faces a Short-run Tradeoff Between Inflation and Unemployment.

- The Phillips Curve illustrates the tradeoff between inflation and unemployment:

↓ Inflation → ↑ Unemployment

It's a short-run tradeoff!

Important issues in macroeconomics

- Why does the cost of living keep rising?
- Why are millions of people unemployed, even when the economy is booming?
- Why are there recessions?
Can the government do anything to combat recessions? Should it??
- What is the government budget deficit? How does it affect the economy?
- Why do the economies have such a huge trade deficit?
- Why are so many countries poor?
What policies might help them grow out of poverty?

Gross Domestic Product of Pakistan



IMPORTANCE OF MACROECONOMICS

Why learn macroeconomics?

1. The macroeconomy affects society's well-being.
 - ♦ example:
Unemployment and social problems
Each one-point increase in the unemployment rate is associated with:
 - ♦ 920 more suicides
 - ♦ 650 more homicides
 - ♦ 4000 more people admitted to state mental institutions
 - ♦ 3300 more people sent to state prisons
 - ♦ 37,000 more deaths
 - ♦ increases in domestic violence and homelessness
 - ♦ The macroeconomy affects your well-being.
 - ♦ example 1:
Unemployment and earnings growth
 - ♦ example 2:
Interest rates and mortgage payments



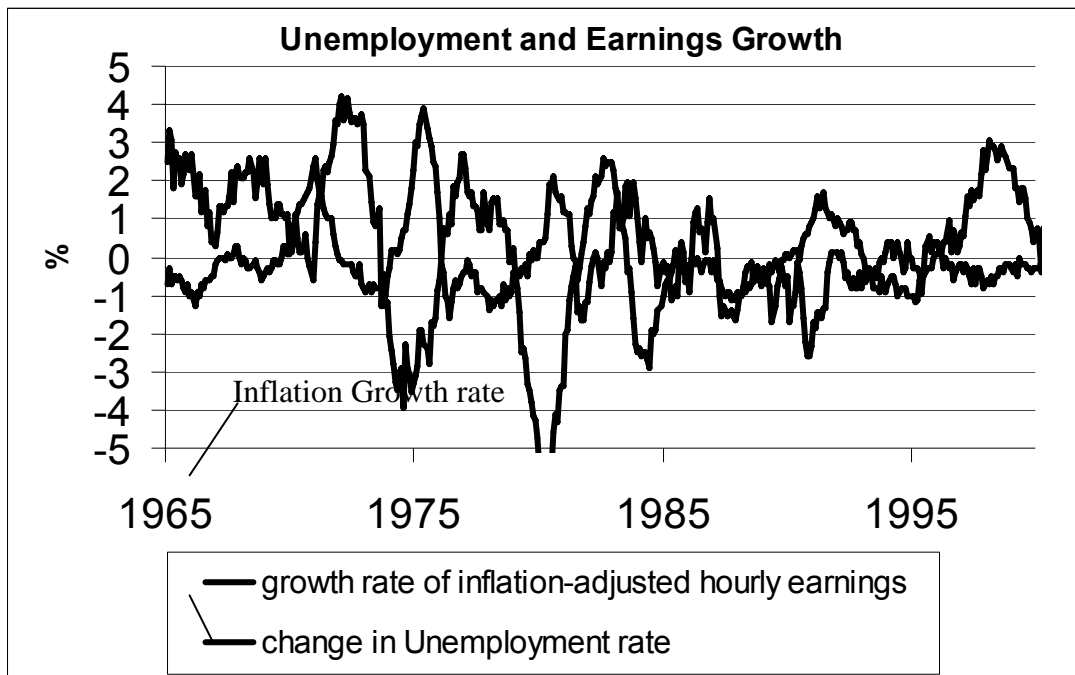

Interest rates and rental payments

For a Rs.320,000; 3-year mortgage

Date	actual rate on 3-year financing	monthly payment	annual payment
May 2003	8.50%	Rs. 10,021	Rs. 120,252
May 2004	7.25%	Rs. 9,839	Rs. 118,068

Why learn macroeconomics?

- 3. The macroeconomy affects politics & current events.
 - example:
Inflation and unemployment in election years

Inflation and Unemployment in Election Years

Year	U rate	inflation rate
1976	7.7%	5.8%
1980	7.1%	13.5%
1984	7.5%	4.3%
1988	5.5%	4.1%
1992	7.5%	3.0%
1996	5.4%	3.3%
2000	4.0%	3.4%

Economic models

...are simplified versions of a more complex reality

- irrelevant details are stripped away

Used to

- show the relationships between economic variables
- explain the economy's behavior
- devise policies to improve economic performance

The supply & demand for new cars

- explains the factors that determine the price of cars and the quantity sold.
- assumes the market is competitive: each buyer and seller is too small to affect the market price
- Variables:

Q_d = quantity of cars that buyers demand

Q_s = quantity that producers supply

P = price of new cars

Y = aggregate income

P_s = price of steel (an input)

The demand for cars

Demand Equation

$$Q_d = D(P, Y)$$

shows that the quantity of cars consumers demand is related to the price of cars and aggregate income.

- General functional notation shows only that the variables are related:

$$Q_d = D(P, Y)$$

THE DATA OF MACROECONOMICS

THE CIRCULAR FLOW

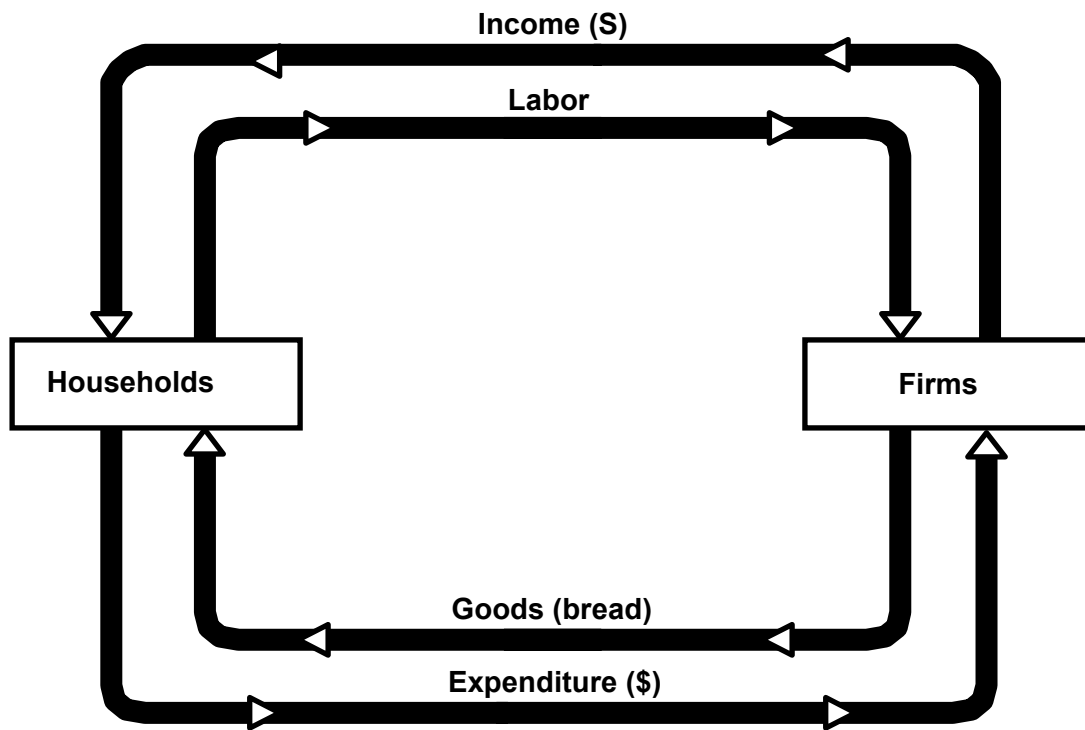

“Expenditure = Income” Why?

In every transaction,
the buyer’s expenditure becomes the seller’s income.

Thus, the sum of all expenditure equals
the sum of all income

Rules for computing GDP

- 1) To compute the total value of different goods and services, the national income accounts use market prices.

Thus, if



$$\begin{aligned} \text{GDP} &= [P(A) \times Q(A)] + [P(O) \times Q(O)] \\ &= (\$0.50 \times 4) + (\$1.00 \times 3) \end{aligned}$$

$$\text{GDP} = \$5.00$$

- 2) Used goods are **not** included in the calculation of GDP.
- 3) Treatment of inventories depends on if the goods are stored or if they spoil.
- 4) Intermediate goods are not counted in GDP— only the value of final goods.

Value added of a firm equals the value of the firm's output less the value of the intermediate goods the firm purchases.

Example

- A farmer grows a bushel of wheat and sells it to a miller for \$1.00
- The miller turns the wheat into flour and sells it to a baker for \$3.00
- The baker uses the flour to make a loaf of bread and sells it to an engineer for \$6.00
- The engineer eats the bread
- Compute
 - value added at each stage of production
 - GDP
- The value of the final goods already includes the value of the intermediate goods, so including intermediate goods in GDP would be double-counting.
- Thus,

Expenditure = Income = Sum of value added

5) Some goods are not sold in the marketplace and therefore don't have market prices. We must use their imputed value as an estimate of their value. For example, home ownership and government services.

- Apt Rent will be included in GDP.
 - Your expenditure and landlord's *income*
- How about people who own houses?
 - They pay themselves their rent.
- How about services of police officers, firefighters and senators?
 - All public goods and services
- These are all included in GDP.

Nominal vs Real GDP

- The value of final goods and services measured at current prices is called nominal GDP.
- It can change over time either because there is a change in the amount (real value) of goods and services or a change in the prices of those goods and services.
- Hence, nominal GDP

$$Y = P \times y$$

where **P** is the price level & **y** is real output

- Real GDP or,

$$y = Y/P$$

is the value of goods and services measured using a constant set of prices?

- This distinction between real and nominal can also be applied to other monetary values, like wages. Nominal (or money) wages can be denoted by (**W**) and decomposed into a real value (**w**) and a price variable (**P**). Hence,

$$W = \text{nominal wage} = P \times w$$

$$w = \text{real wage} = W/P$$

This conversion from nominal to real units allows us to eliminate the problems created by having a measuring stick (dollar value) that essentially changes length over time, as the price level changes.

Apple & Orange Economy

Let's see how real GDP is computed in our apple and orange economy.

For example, if we wanted to compare output in 2002 and output in 2003, we would obtain base-year prices, such as 2002 prices.

- Real GDP in 2002 would be:

$$[2002 P (A) \times 2002 Q (A)] + [2002 P(O) \times 2002 Q(O)]$$

- Real GDP in 2003 would be:

$$[(2002 P (A) \times 2003 Q (A)) + [(2002 P (O) \times 2003 Q (O))]$$

- Real GDP in 2004 would be:

$$[(2002 P (A) \times 2004 Q (A)) + [(2002 P (O) \times 2004 Q (O))]$$

THE DATA OF MACROECONOMICS (Continued...)

Nominal vs. Real GDP

	2001		2002		2003	
	P	Q	P	Q	P	Q
good A	Rs30	900	Rs31	1,000	Rs36	1,050
good B	Rs100	192	Rs102	200	Rs100	205

- Compute nominal GDP in each year
- Compute real GDP in each year using 2001 as the base year.
- Nominal GDP
multiply Ps & Qs from same year
2001: Rs46, 200 = \$30 × 900 + \$100 × 192
2002: Rs51, 400
2003: Rs58, 300
- Real GDP
multiply each year's Qs by 2001 Ps
2001: Rs46, 300

2002: Rs50,000

2003: Rs52,000 = \$30×1050 + \$100 × 205

GDP Deflator

The GDP deflator, also called the implicit price deflator for GDP, measures the price of output relative to its price in the base year. It reflects what's happening to the overall level of prices in the economy

$$\text{GDP Deflator} = \frac{\text{Nominal GDP}}{\text{Real GDP}}$$

	Nom. GDP	Real GDP	GDP deflator	inflation rate
2001	Rs46,200	Rs46,200	100.0	<i>n.a.</i>
2002	51,400	50,000	102.8	2.8%
2003	58,300	52,000	112.1	9.1%

Chain-Weighted Measures of GDP

- In some cases, it is misleading to use base year prices that prevailed 10 or 20 years ago (i.e. computers and college). The base year changes continuously over time.

- New chain-weighted measure is better than the more traditional measure because it ensures that prices will not be too out of date.
- Average prices in 2001 and 2002 are used to measure real growth from 2001 to 2002.
- Average prices in 2002 and 2003 are used to measure real growth from 2002 to 2003 and so on.
- These growth rates are united to form a chain that is used to compare output between any two dates.

Components of Expenditures

$$Y = C + I + G + NX$$

Y => Total Demand for domestic

C => Consumption Spending by Households

I => Investment spending by businesses and households

G => Govt. purchases of goods and services

NX=> Net exports or net foreign demand

Consumption (C)

Definition: the value of all goods and services bought by households. Includes:

- **durable goods** last a long time
ex: cars, home appliances
- **non-durable goods** last a short time
ex: food, clothing
- **Services** work done for consumers
ex: dry cleaning, air travel.

Investment (I)

Definition 1: spending on [the factor of production] capital.

Definition 2: spending on goods bought for future use.

Includes:

- Business Fixed Investment spending on plant and equipment that firms will use to produce other goods & services
- Residential Fixed Investment spending on housing units by consumers and landlords
- Inventory Investment the change in the value of all firms' inventories

Investment vs. Capital

- Capital is one of the factors of production.
At any given moment, the economy has a certain overall stock of capital.
- Investment is spending on new capital.

Example (assumes no depreciation):

- 1/1/2002:
economy has Rs500b worth of capital
- during 2002:
investment = Rs37b
- 1/1/2003:
economy will have Rs537b worth of capital

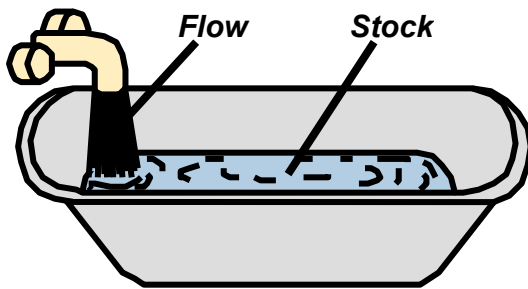
Stocks vs. Flows

More examples:

Stock

a person's wealth
of people with college degrees
the govt. debt

flow

a person's saving
of new college graduates
the govt. budget deficit

What is Investment?

- Ali buys for himself a house (9 years old).
- Saleem built a brand-new house.*
- Baber buys Rs10 million in ABC stock from someone.
- An automobile company sells Rs100 million in stock and builds a new car factory in Lahore.*
- Which one is INVESTMENT included in GDP? Why?

Government spending (G)

- **G** includes all government spending on goods and services.
- **G** excludes transfer payments (e.g. unemployment insurance payments), because they do not represent spending on goods and services.

Net exports (NX = EX - IM)

Definition:

The value of total exports (**EX**) minus the value of total imports (**IM**)

Recall

$$Y = C + I + G + NX$$

Where

$Y = \text{GDP} = \text{the value of total output}$

$C + I + G + NX = \text{aggregate expenditure}$

A question for you:

Suppose a firm

- produces Rs10 million worth of final goods
- but only sells Rs9 million worth.

Does this violate the expenditure = *output* identity?

Why output = expenditure

- Unsold output goes into inventory, and is counted as "inventory investment" ...
...whether the inventory buildup was intentional or not.

- In effect, we are assuming that firms purchase their unsold output.

GDP: An important and versatile concept

We have now seen that GDP measures

- total income
- total output
- total expenditure
- the sum of value-added at all stages in the production of final goods

GNP vs. GDP

- **Gross National Product (GNP):**
total income earned by the nation's factors of production, regardless of where located
- **Gross Domestic Product (GDP):**
total income earned by domestically-located factors of production, regardless of nationality.

$(\text{GNP} - \text{GDP}) = (\text{factor payments from abroad}) - (\text{factor payments to abroad})$

In Pakistan,
which would you want
to be bigger,
GDP or GNP?
Why?

$(\text{GNP} - \text{GDP})$ as a % of GDP for selected countries, 1997.

USA	0.1%
Bangladesh	3.3
Brazil	-2.0
Canada	-3.2
Chile	-8.8
Ireland	-16.2
Kuwait	20.8
Mexico	-3.2
Saudi Arabia	3.3
Singapore	4.2

THE DATA OF MACROECONOMICS (Continued...)

Other Measures of Income

- **Net National Product (NNP) =**
GNP – Depreciation
- **National Income (NI) =**
NNP – Indirect Business Taxes
- **Personal Income (PI) =**
NI – Corporate Profits
– Social Insurance Contributions
– Net Interest
+ Dividends
+ Govt. Transfers to Individuals
+ Personal Interest Income
- **Disposable Personal Income (DPI) =**
PI – Tax

CONSUMER PRICE INDEX (CPI)

- A measure of the overall level of prices
- Published by the Federal **Bureau of Statistics**
- Used to
 - track changes in the typical household's cost of living
 - adjust many contracts for inflation (*i.e.* "COLAs": Cost of Living Adjustments)
 - allow comparisons of dollar figures from different years

How to construct the CPI

1. Survey consumers to determine composition of the typical consumer's "basket" of goods.
2. Every month, collect data on prices of all items in the basket; compute cost of basket
3. CPI in any month equals

$$100 \times \frac{\text{Cost of basket in that month}}{\text{Cost of basket in base period}}$$

CPI: an example

The basket contains 20 pizzas and 10 compact discs.

Prices:		
	Pizza	CDs
2000	\$10	\$15
2001	\$11	\$15
2002	\$12	\$16
2003	\$13	\$15

For each year, compute

- the cost of the basket
- the CPI (use 2000 as the base year)
- the inflation rate from the preceding year

	Cost of basket	CPI	inflation rate
2000	\$350	100.0	N.A.
2001	370	105.7	5.7%
2002	400	114.3	8.1%
2003	410	117.1	2.5%

Understanding the CPI

Example with 3 goods

For good $i = 1, 2, 3$

C_i = the amount of good i in the CPI's basket

P_{it} = the price of good i in month t

E_t = the cost of the CPI basket in month t

E_b = cost of the basket in the base period

$$\begin{aligned} \text{CPI in month } t &= 100 \times \frac{E_t}{E_b} \\ &= 100 \times \frac{P_{1t}C_1 + P_{2t}C_2 + P_{3t}C_3}{E_b} \\ &= 100 \times \left[\left(\frac{C_1}{E_b} \right) P_{1t} + \left(\frac{C_2}{E_b} \right) P_{2t} + \left(\frac{C_3}{E_b} \right) P_{3t} \right] \end{aligned}$$

The CPI is a weighted average of prices.

The weight on each price reflects that good's relative importance in the CPI's basket.

Note that the weights remain fixed over time.

Reasons why the CPI may overstate inflation

- **Substitution bias:** The CPI uses fixed weights, so it cannot reflect consumers' ability to substitute toward goods whose relative prices have fallen.
CPI uses fixed weights.
- **Introduction of new goods:** The introduction of new goods makes consumers better off and, in effect, increases the real value of the dollar. But it does not reduce the CPI, because the CPI uses fixed weights.
- **Unmeasured changes in quality:** Quality improvements increase the value of the dollar, but are often not fully measured.

CPI vs. GDP deflator

prices of capital goods

- included in GDP deflator (if produced domestically)
- excluded from CPI

prices of imported consumer goods

- included in CPI
- excluded from GDP deflator

the basket of goods

- CPI: fixed
- GDP deflator: changes every year

CATEGORIES OF THE POPULATION

- **Employed**
working at a paid job
- **Unemployed**
not employed but looking for a job
- **Labor force**
the amount of labor available for producing goods and services; all employed plus unemployed persons
- **Not in the labor force**
not employed, not looking for work.

Two important labor force concepts

- **unemployment rate**
percentage of the labor force that is unemployed

$$\text{Unemployment Rate} = \frac{\text{Number of Unemployed}}{\text{Labor Force}} \times 100$$

- **labor force participation rate**
the fraction of the adult population that ‘participates’ in the labor force

$$\text{Labor-Force Participation Rate} = \frac{\text{Labor Force}}{\text{Adult Population}} \times 100$$

Suppose

- the population increases by 1%
- the labor force increases by 3%
- the number of unemployed persons increases by 2%

Okun’s Law

- One would expect a negative relationship between unemployment and real GDP.
- This relationship is clear in the data...

$$\text{Percentage Change in Real GDP} = 3\% - 2 * (\text{change in the Unemployment rate})$$

Okun’s Law states that a one-percent decrease in unemployment is associated with two percentage points of additional growth in real GDP

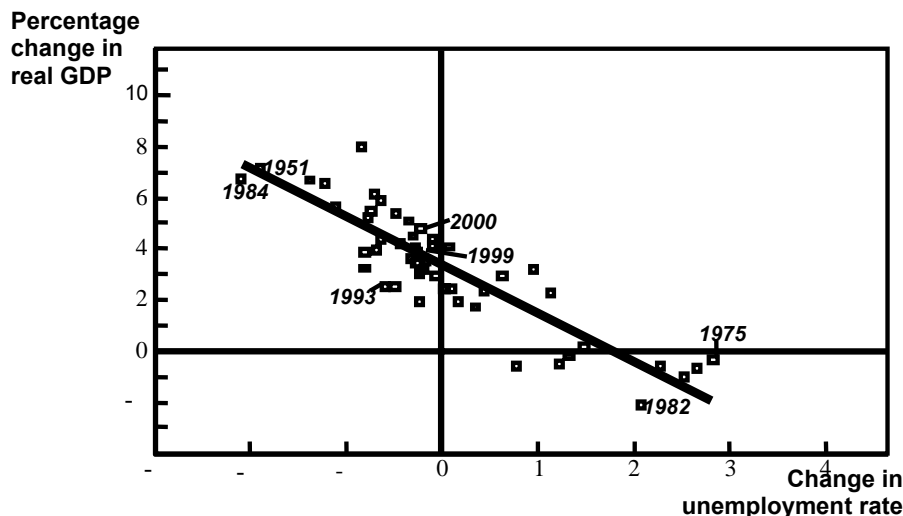

NATIONAL INCOME: WHERE IT COMES FROM AND WHERE IT GOES

Key Questions to be addressed

- What determines the economy's total output/income
- How the prices of the factors of production are determined
- How total income is distributed
- What determines the demand for goods and services
- How equilibrium in the goods market is achieved

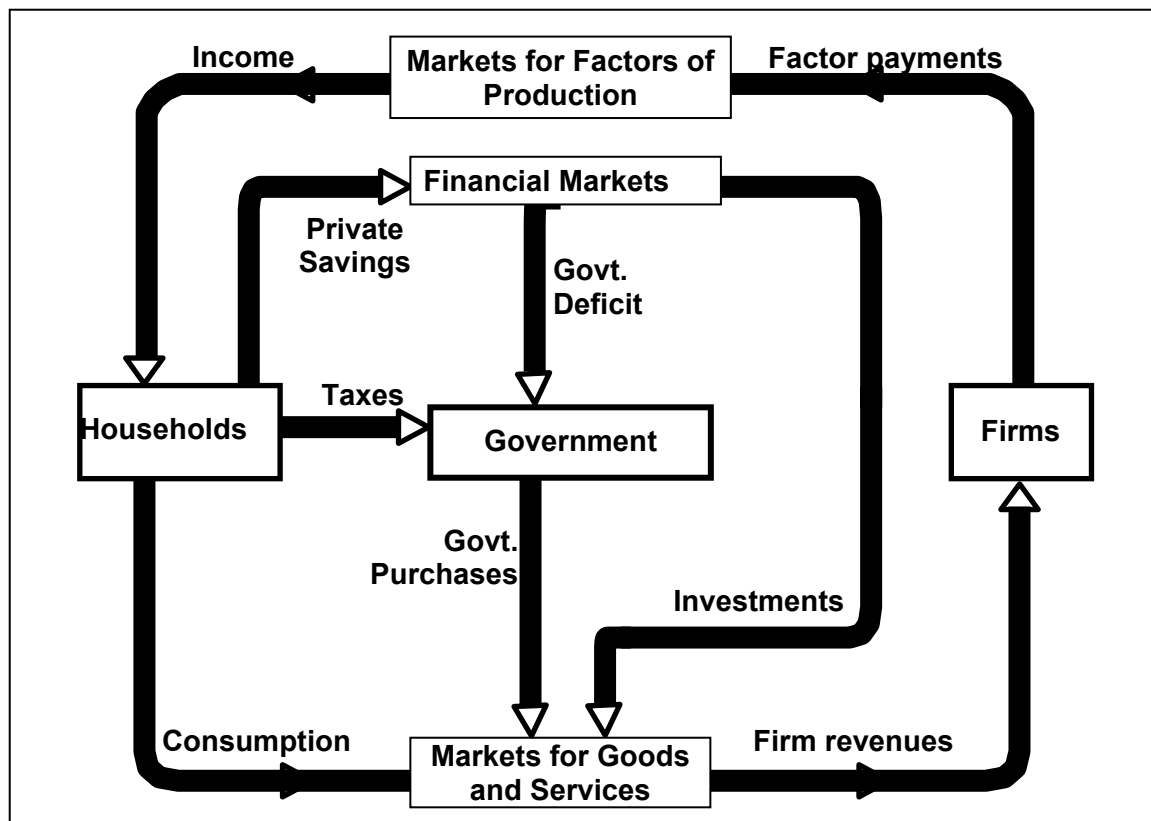

OUTLINE OF MODEL

(A closed economy, market-clearing model)

Supply side

- factor markets (supply, demand, price)
- determination of output/income

Demand side

- determinants of C , I , and G

Equilibrium

- goods market
- loanable funds market

Factors of production

K = capital, tools, machines, and structures used in production

L = labor, the physical and mental efforts of workers

The production function

- denoted $Y = F(K, L)$
- shows how much output (Y) the economy can produce from K units of capital and L units of labor.
- reflects the economy's level of technology.
- exhibits constant returns to scale.

Assumptions of the model

Technology is fixed.

The economy's supplies of capital and labor are fixed at

$$K = \bar{K} \quad \text{and} \quad L = \bar{L}$$

Determining GDP

Output is determined by the fixed factor supplies and the fixed state of technology:

$$\bar{Y} = F(\bar{K}, \bar{L})$$

The distribution of national income

- determined by **factor prices**, the prices per unit that firms pay for the factors of production.
- The **wage** is the price of L , the **rental rate** is the price of K .

Notation

W = Nominal Wage

R = Nominal Rental Rate

P = Price of Output

W/P = Real Wage (Measured in Units of Output)

R/P = Real Rental Rate

How factor prices are determined

- Factor prices are determined by supply and demand in factor markets.
- Recall: Supply of each factor is fixed.
- What about demand?

Demand for labor

- Assume markets are competitive:
each firm takes W , R , and P as given
- Basic idea:
A firm hires each unit of labor
if the cost does not exceed the benefit.
Cost = real wage
Benefit = marginal product of labor

Marginal product of labor (MPL)

def:

The extra output the firm can produce using an additional unit of labor (holding other inputs fixed):

$$MPL = F(K, L + 1) - F(K, L)$$

Production Function

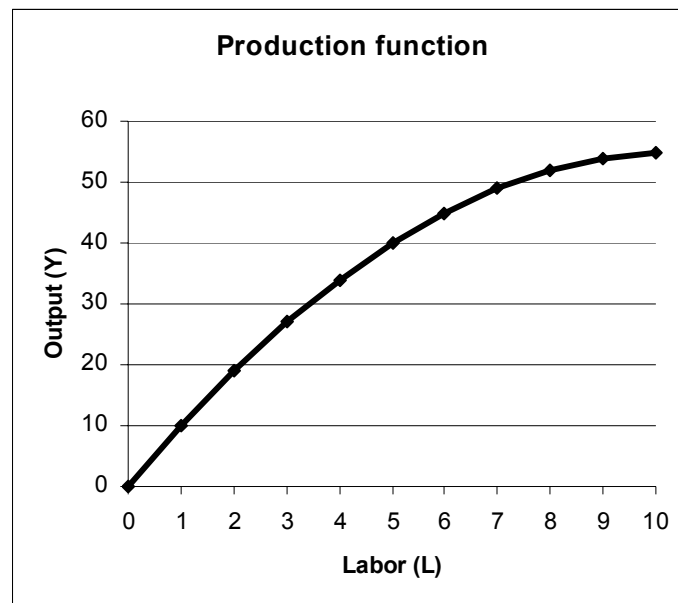

Marginal Product of Labor

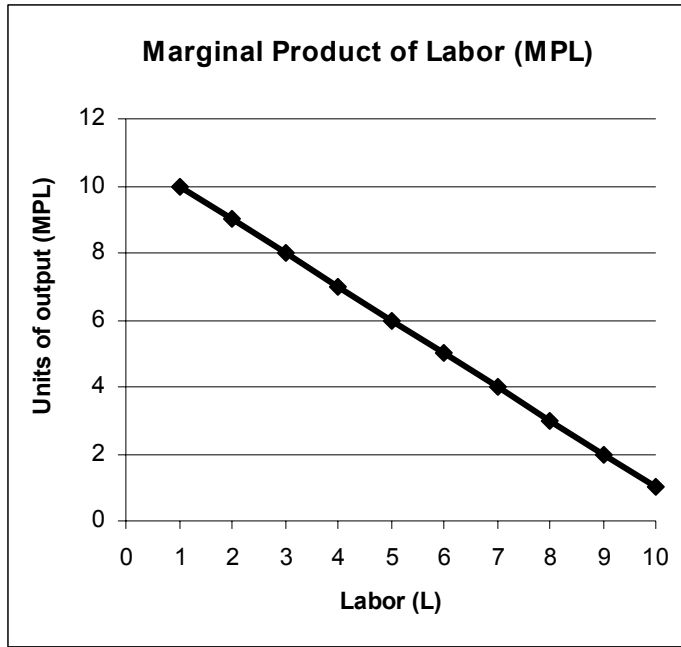

The MPL and the production function

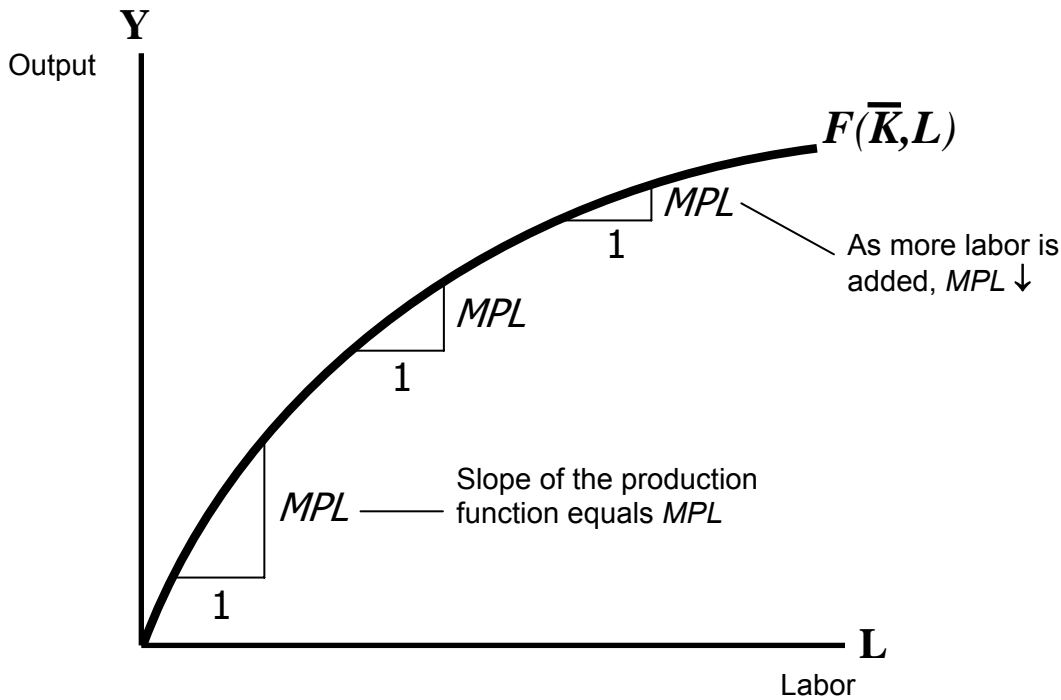

Diminishing marginal returns

- As a factor input is increased, its marginal product falls (other things equal).
 - Intuition:
 - ↑L while holding K fixed
- ⇒ Fewer machines per worker
 ⇒ Lower productivity

MPL and the demand for labor

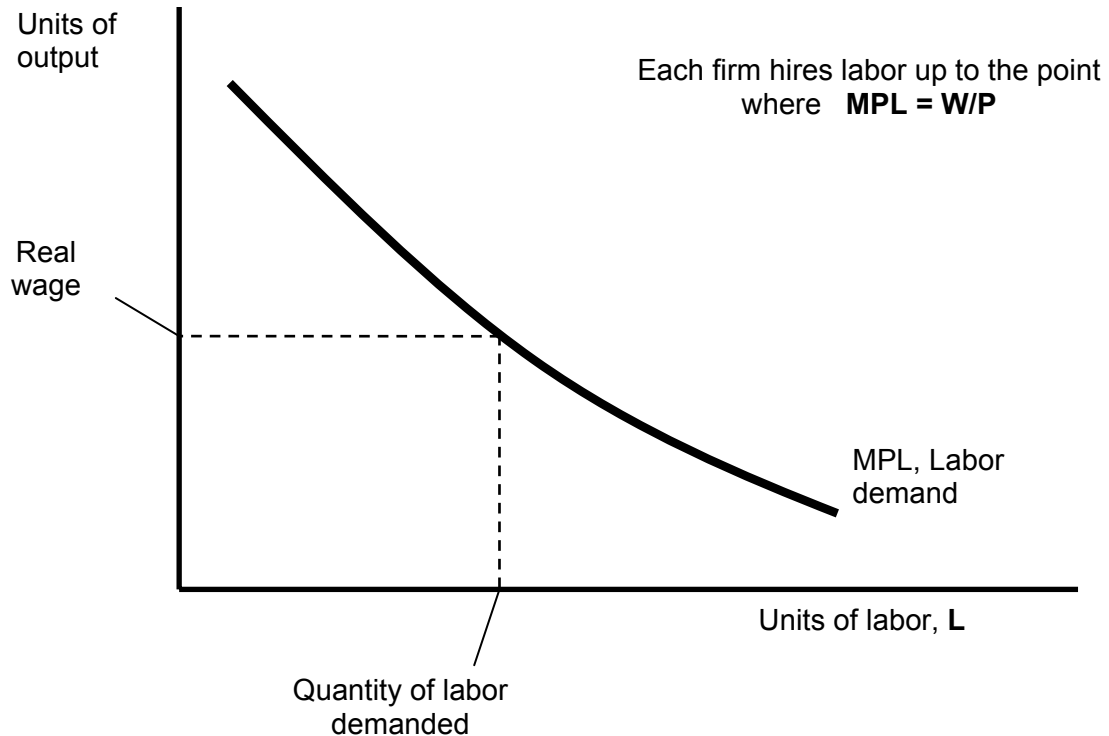

Determining the rental rate

We have just seen that $MPL = W/P$

The same logic shows that $MPK = R/P$:

- Diminishing returns to capital: $MPK \downarrow$ as $K \uparrow$
- MPK curve is the firm's demand curve for renting capital.
- Firms maximize profits by choosing K such that $MPK = R/P$.

NATIONAL INCOME: WHERE IT COMES FROM AND WHERE IT GOES (Continued...)

Marginal product of labor (*MPL*)

def:

The extra output the firm can produce using an additional unit of labor (holding other inputs fixed):

$$MPL = F(K, L + 1) - F(K, L)$$

Diminishing marginal returns

- As a factor input is increased, its marginal product falls (other things equal).
- Intuition:
 - ↑L while holding K fixed
 - ⇒ fewer machines per worker
 - ⇒ lower productivity

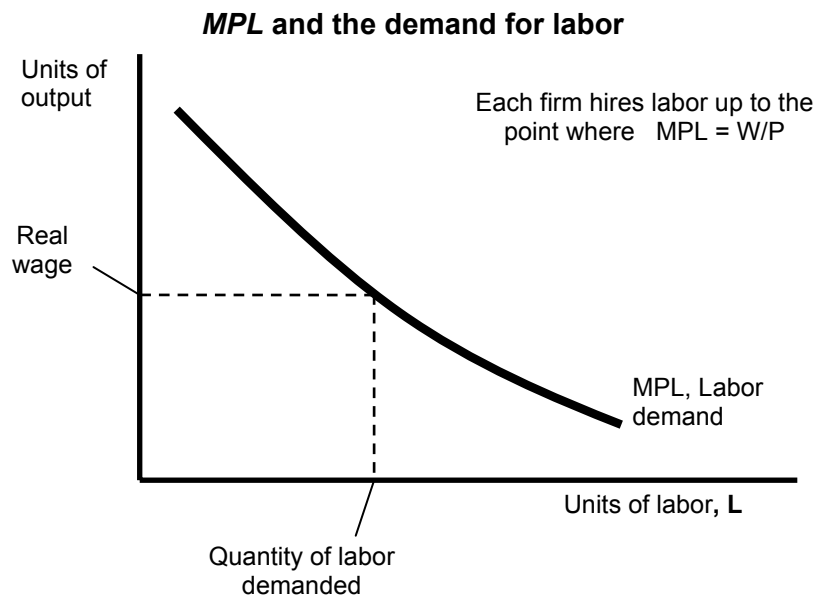

Determining the rental rate

We have just seen that $MPL = W/P$

The same logic shows that $MPK = R/P$:

- diminishing returns to capital: $MPK \downarrow$ as $K \uparrow$
- MPK curve is the firm's demand curve for renting capital.
- Firms maximize profits by choosing K such that $MPK = R/P$.

The Neoclassical Theory of Distribution

- states that each factor input is paid its marginal product
- accepted by most economists

How income is distributed:

$$\text{Total labor income} = W/P \times \bar{L} = \text{MPL} \times \bar{L}$$

$$\text{Total capital income} = R/P \times \bar{K} = \text{MPK} \times \bar{K}$$

If production functions has a constant return to scale, then

$$\bar{Y} = \text{MPL} \times \bar{L} + \text{MPK} \times \bar{K}$$

Outline of model

A closed economy, market-clearing model

Supply side

- Factor markets (supply, demand, price) [Done]
- Determination of output/income [Done]

Demand side

- Determinants of C , I , and G [Next]

Equilibrium

- Goods market
- Loanable funds market

Demand for goods & services

Components of aggregate demand:

C = consumer demand for g & s

I = demand for investment goods

G = government demand for g & s

(Closed economy: no NX)

Consumption, C

- **def:** disposable income is total income minus total taxes: $Y - T$
- Consumption function: $C = C(Y - T)$

Shows that $\uparrow(Y - T) \Rightarrow \uparrow C$

Consumption, C

- **Def.** The **marginal propensity to consume** is the increase in C caused by a one-unit increase in disposable income.

The consumption function

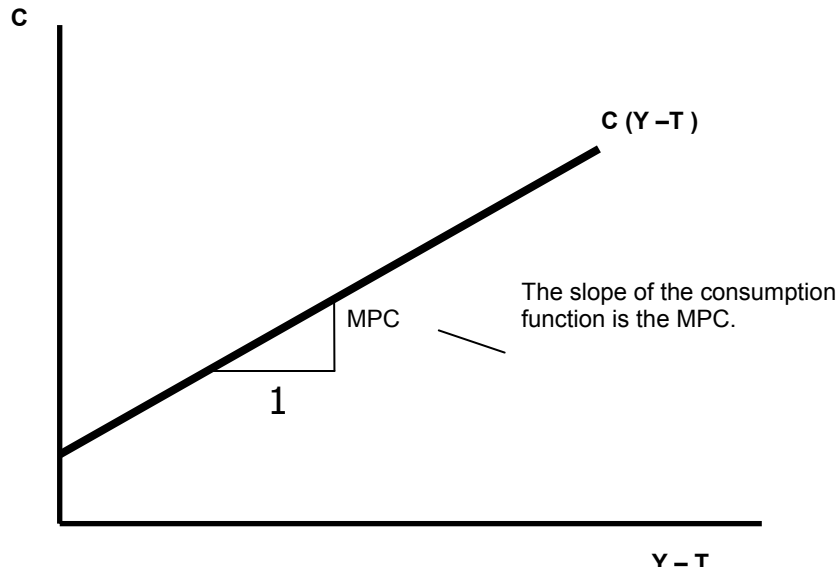

Investment, I

- The investment function is $I = I(r)$

Where r denotes the real interest rate, the nominal interest rate corrected for inflation.

Investment, I

- The real interest rate is
 - the cost of borrowing
 - the opportunity cost of using one's own funds to finance investment spending.
- So, $\uparrow r \Rightarrow \downarrow I$

The investment function

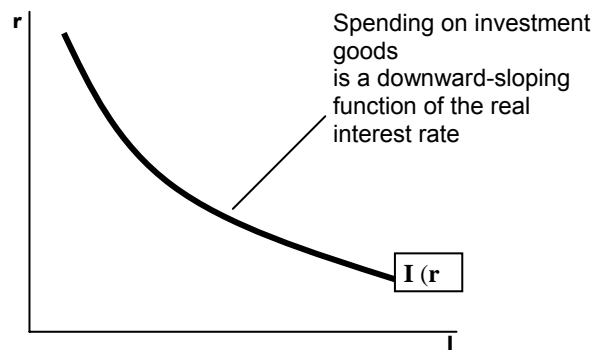

LESSON 09

NATIONAL INCOME: WHERE IT COMES FROM AND WHERE IT GOES (Continued...)

Government spending, G

- G includes government spending on goods and services.
- G excludes transfer payments
 - Assume government spending and total taxes are exogenous:

The market for goods & services

Summarizing the Discussion so far:

$$\begin{aligned} Y &= C + I + G \\ C &= C(Y - T) \\ I &= I(r) \\ G &= G \\ T &= T \end{aligned}$$

Market for goods & services

Agg. Demand:

$$C(\bar{Y} - \bar{T}) + I(r) + \bar{G}$$

Agg. Supply:

$$\bar{Y} = F(\bar{K}, \bar{L})$$

Equilibrium:

$$\bar{Y} = C(\bar{Y} - \bar{T}) + I(r) + \bar{G}$$

The real interest rate adjusts
to equate demand with supply.

The loanable funds market

A simple supply-demand model of the financial system.

One asset:	“loanable funds”
demand for funds:	investment
supply of funds:	saving
“price” of funds:	real interest rate

Demand for funds: Investment

The demand for loanable funds:

- Comes from investment:
Firms borrow to finance spending on plant & equipment, new office buildings, etc.
Consumers borrow to buy new houses.
- Depends negatively on r , the “price” of loanable funds (the cost of borrowing).

Loanable funds demand curve

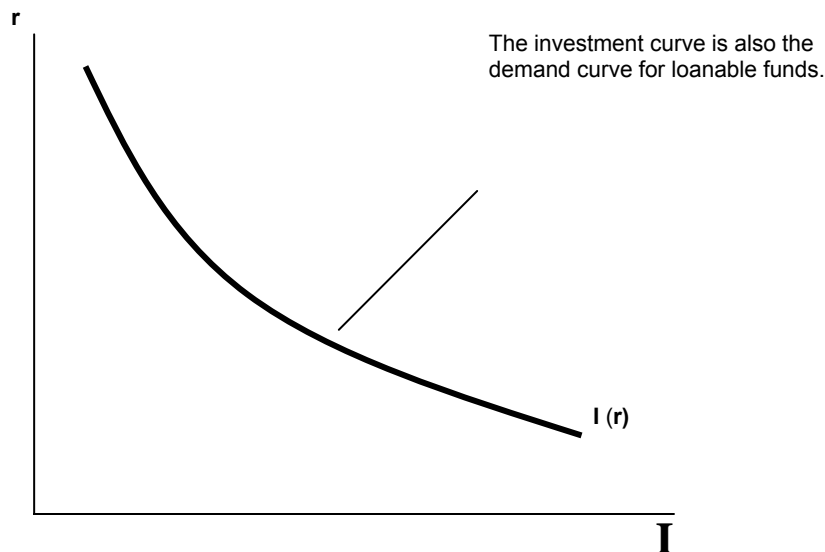

Supply of funds: Saving

The supply of loanable funds comes from saving:

- Households use their saving to make bank deposits, purchase bonds and other assets. These funds become available to firms to borrow to finance investment spending.
- The government may also contribute to saving if it does not spend all of the tax revenue it receives.

Types of saving

- Private saving = $(Y - T) - C$
- Public saving = $T - G$
- National saving, S
= private saving + public saving
= $(Y - T) - C + T - G$
= $Y - C - G$

Digression:

Budget surpluses and deficits

- When $T > G$, *budget surplus* = $(T - G)$ = public saving
- When $T < G$, budget deficit = $(G - T)$ and public saving is negative.
- When $T = G$, budget is balanced and public saving = 0.

Budget Deficit of Pakistan (as % of GDP)

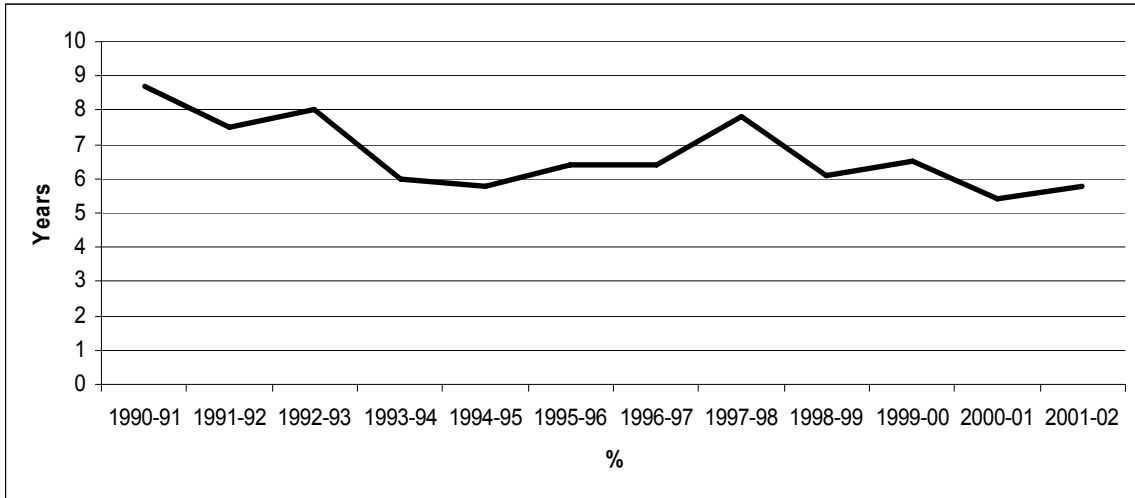

Loanable funds supply curve

National saving does not depend on r , so the supply curve is vertical.

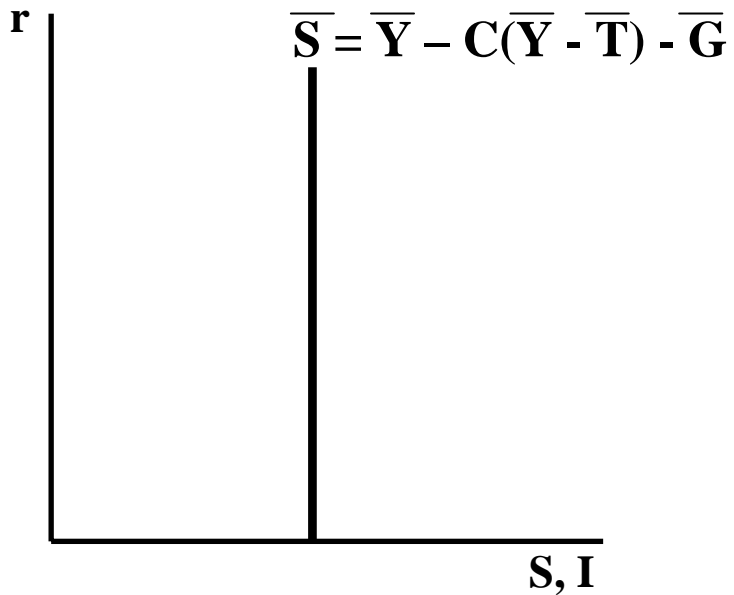

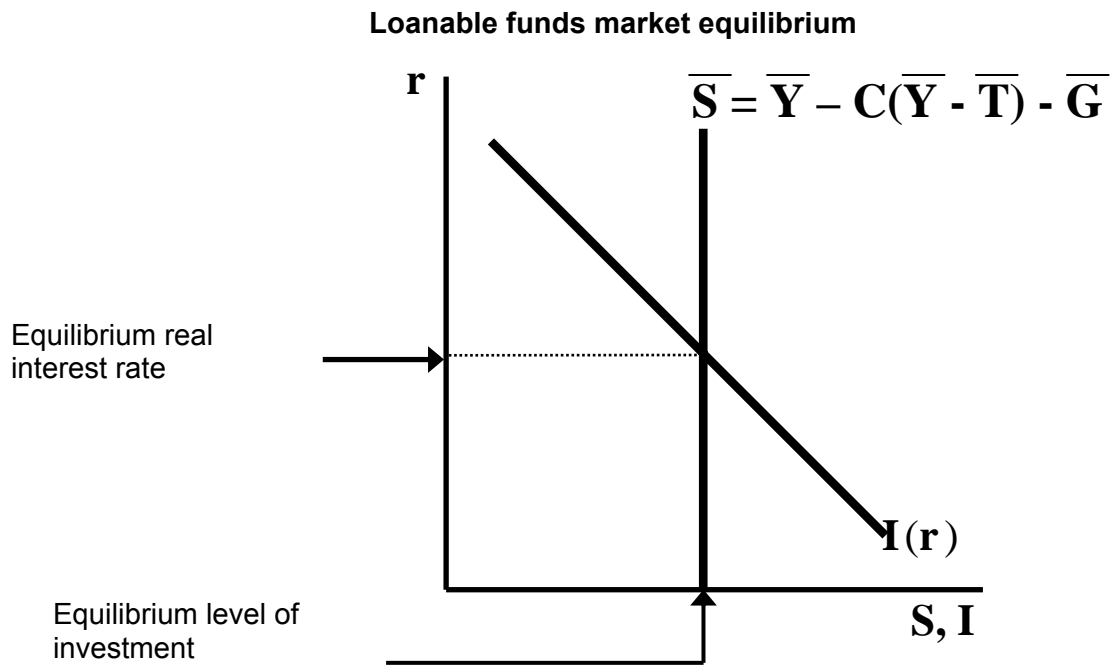

The special role of r

r adjusts to equilibrate the goods market and the loanable funds market simultaneously:

If L.F. market in equilibrium, then

$$S = I \quad \rightarrow \quad (Y - C - G) = I$$

Rewriting as:

$$Y = C + I + G \quad (\text{goods market equilibrium})$$

Thus,

Equilibrium in Loanable funds Market \Leftrightarrow Equilibrium in goods Market

Digression: mastering models

To learn a model well, be sure to know:

1. Which of its variables are endogenous and which are exogenous.
2. For each curve in the diagram, know
 - definition
 - intuition for slope
 - all the things that can shift the curve
3. Use the model to analyze the effects of each item in 2c.

Mastering the loanable funds model

1. Things that shift the saving curve

- Public saving
- Fiscal policy: changes in G or T
- Private saving
- Preferences
- Tax laws that affect saving

Now you try...

- Draw the diagram for the loanable funds model.
- Suppose the tax laws are altered to provide more incentives for private saving.
- What happens to the interest rate and investment?
- (Assume that T doesn't change)

NATIONAL INCOME: WHERE IT COMES FROM AND WHERE IT GOES (Continued...)

The Role of Govt.

- If the Government:
- increases defense spending: $\Delta G > 0$
- big tax cuts: $\Delta T < 0$
- According to our model, both policies reduce national saving:

$$\bar{S} = \bar{Y} - C(\bar{Y} - \bar{T}) - \bar{G}$$

$$\uparrow \bar{G} \Rightarrow \downarrow \bar{S}$$

$$\downarrow \bar{T} \Rightarrow \uparrow C \Rightarrow \downarrow \bar{S}$$

The Role of Govt.

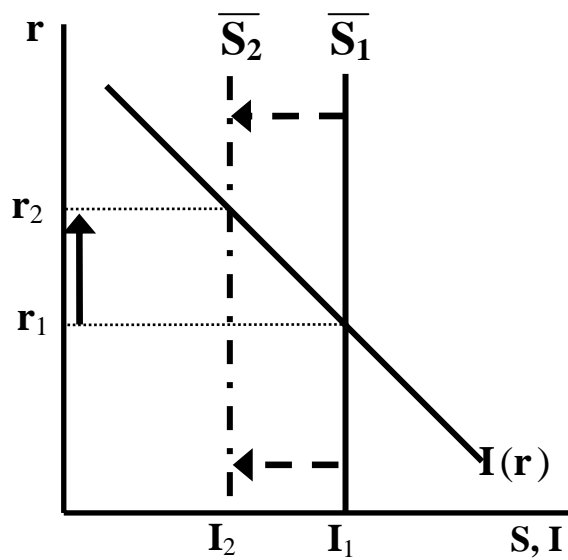

1. The increase in the deficit reduces saving...
2. ...this causes the real interest rate to rise...
3. ...this reduces the level of investment.

An increase in investment demand

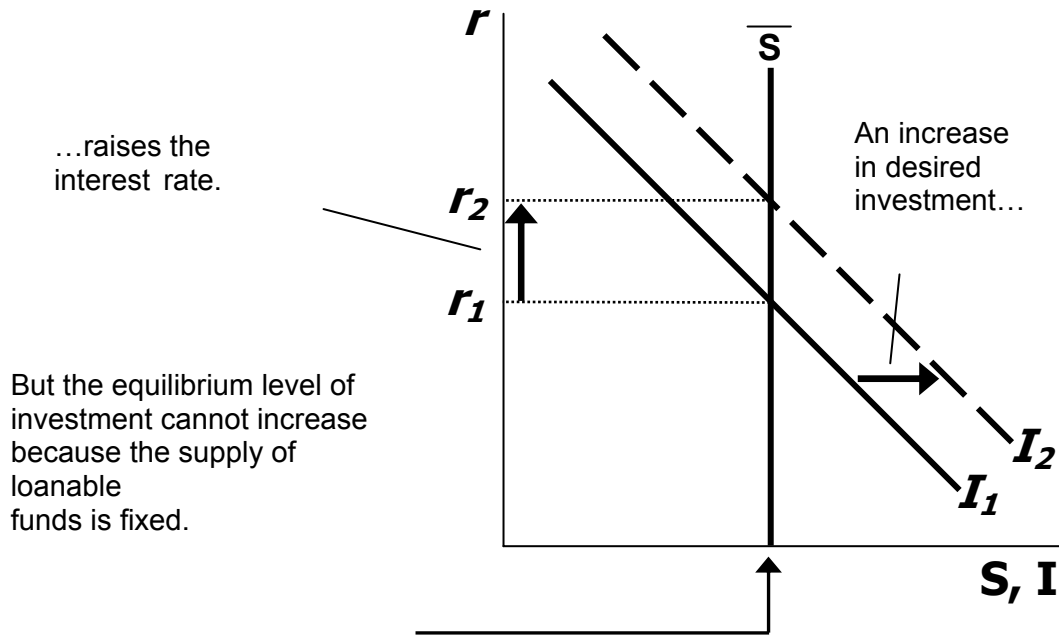

Saving and the interest rate

- Why might saving depend on r ?
- How would the results of an increase in investment demand be different?
 - Would r rise as much?
 - Would the equilibrium value of I change?

Rise in investment demand when saving depends on interest rate

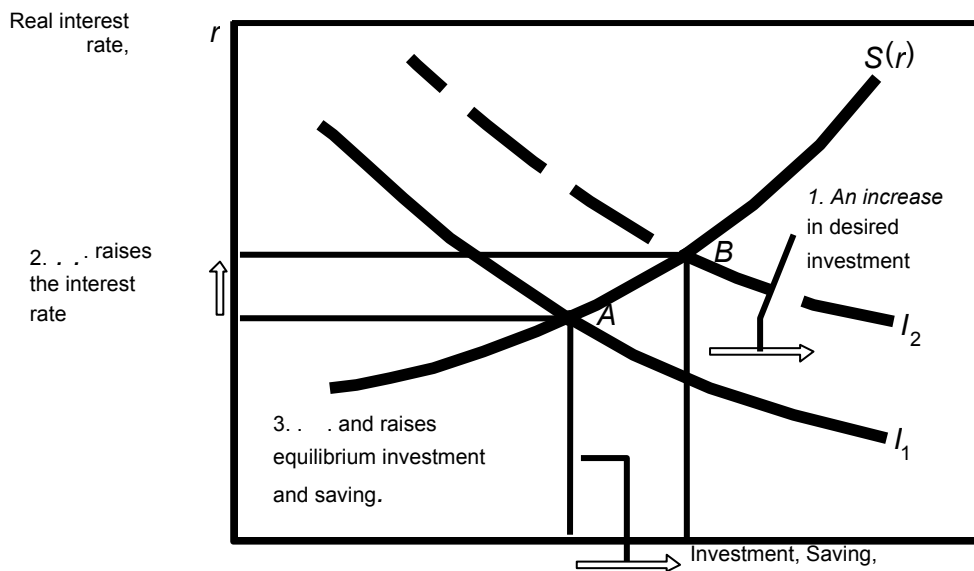

The classical theory of inflation

- Inflation
 - Causes
 - Effects
 - Social costs
 - “Classical” -- assumes prices are flexible & markets clear.
 - Applies to the long run.

Inflation Rate in Pakistan

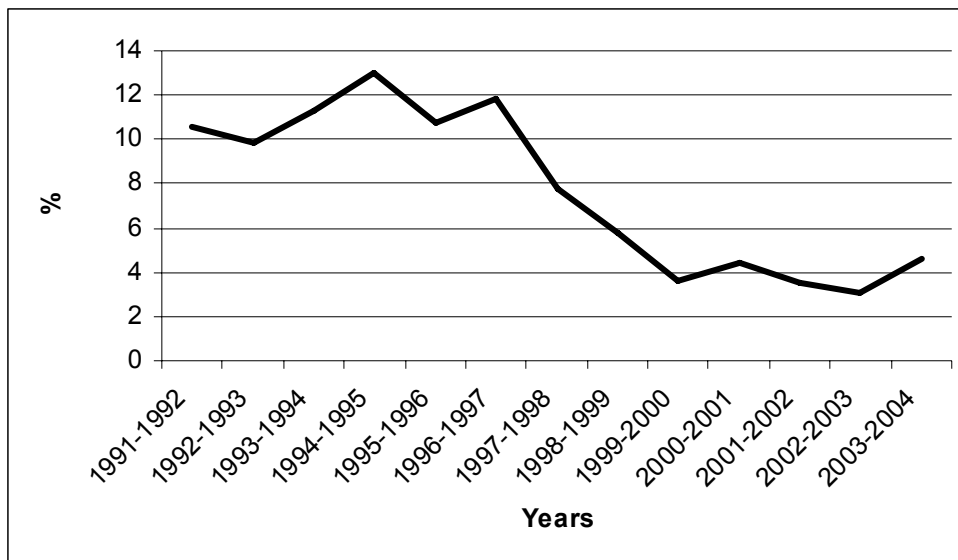

The connection between money and prices

- Inflation rate = the percentage increase in the average level of prices.
- Price = amount of money required to buy a good.
- Because prices are defined in terms of money, we need to consider the nature of money, the supply of money, and how it is controlled.

MONEY: definition

Money is the stock of assets that can be readily used to make transactions.

Money: functions

1. **Medium of exchange**
we use it to buy stuff
2. **Unit of account**
the common unit by which everyone measures prices and values
3. **Store of value**
transfers purchasing power from the present to the future

The ease with which money is converted into other things-- goods and services-- is sometimes called money's liquidity.

Money: Types

1. Fiat money

- has no intrinsic value
- example: the paper currency we use

2. Commodity money

- has intrinsic value
- examples: gold coins,

Which of these is money?

- a. Currency
- b. Checks
- c. Deposits in checking accounts (called demand deposits)
- d. Credit cards
- e. Certificates of deposit (called time deposits)

The money supply & monetary policy

- The money supply is the quantity of money available in the economy.
- Monetary policy is the control over the money supply.

The Central Bank

- Monetary policy is conducted by a country's central bank.
- In Pakistan, the central bank is called State Bank of Pakistan (SBP).
 - To expand the Money Supply:
The State Bank buys **Treasury Bills** and pays for them with new money.
 - To reduce the Money Supply:
The State Bank sells **Treasury Bills** and receives the existing dollars and then destroys them.

State Bank controls the money supply in three ways.

- **Open Market Operations** (buying and selling Treasury bills).
- **Δ Reserve requirements.**
- **Δ Discount rate** which commercial banks pay to borrow from the State Bank.

The Quantity Theory of Money

- A simple theory linking the inflation rate to the growth rate of the money supply.
- Begins with a concept called “velocity”...

Velocity

- Basic concept: the rate at which money circulates
- Definition: the number of times the average rupee bill changes hands in a given time period
- Example:
- Rs50 billion in transactions
- Money supply = Rs10 billion
- The average rupee is used in five transactions
- So, velocity = 5
- This suggests the following definition:

$$V = T / M$$

where

V = velocity

T = value of all transactions

M = money supply

Velocity

- Use nominal GDP as a proxy for total transactions.

Then,

$$V = (P \times Y) / M$$

The Quantity Equation

- The quantity equation

$$M \times V = P \times Y$$
follows from the preceding definition of velocity.
- It is an identity:
it holds by definition of the variables.

MONEY AND INFLATION

Money supply measures

Symbol	Assets included
C	Currency
M1	C + demand deposits, travelers' checks, other checkable deposits
M2	M1 + small time deposits, savings deposits, money market mutual funds, money market deposit accounts
M3	M2 + large time deposits, repurchase agreements, institutional money market mutual fund balances

The Quantity Equation

- The quantity equation

$$M \times V = P \times Y$$
follows from the preceding definition of velocity.
- It is an identity:
it holds by definition of the variables.

Money demand and the quantity equation

- Let's now express the quantity of money in terms of the quantity of goods and services it can buy;
- $M/P = \text{real money balances}$, the purchasing power of the money supply.
- A simple money demand function:

$$(M/P)^d = k Y$$
where
 $k = \text{how much money people wish to hold for each rupee of income}$ (k is exogenous)
- This equation states that the quantity of real money balances demanded is proportional to real income.
- Money demand: $(M/P)^d = k Y$
- Quantity equation: $M \times V = P \times Y$
- The connection between them: $k = 1/V$
- When people hold lots of money relative to their incomes (k is high), money changes hands infrequently (V is low).

THE QUANTITY THEORY OF MONEY

- Recall
The growth rate of a product equals the sum of the growth rates.
- The quantity equation in growth rates:

$$\frac{\Delta M}{M} + \frac{\Delta V}{V} = \frac{\Delta P}{P} + \frac{\Delta Y}{Y}$$

The quantity theory of money assumes

V is constant, so $\frac{\Delta V}{V} = 0$.

Let π (Greek letter "pi") denote the inflation rate:

$$\pi = \frac{\Delta P}{P}$$

We have

$$\frac{\Delta M}{M} = \frac{\Delta P}{P} + \frac{\Delta Y}{Y}$$

Solve this result for π to get

$$\pi = \frac{\Delta M}{M} - \frac{\Delta Y}{Y}$$

- Normal economic growth requires a certain amount of money supply growth to facilitate the growth in transactions.
- Money growth in excess of this amount leads to inflation.

$\Delta Y/Y$ depends on growth in the factors of production and on technological progress (all of which we take as given, for now).

Hence, the Quantity Theory of Money predicts a one-for-one relation between changes in the money growth rate and changes in the inflation rate.

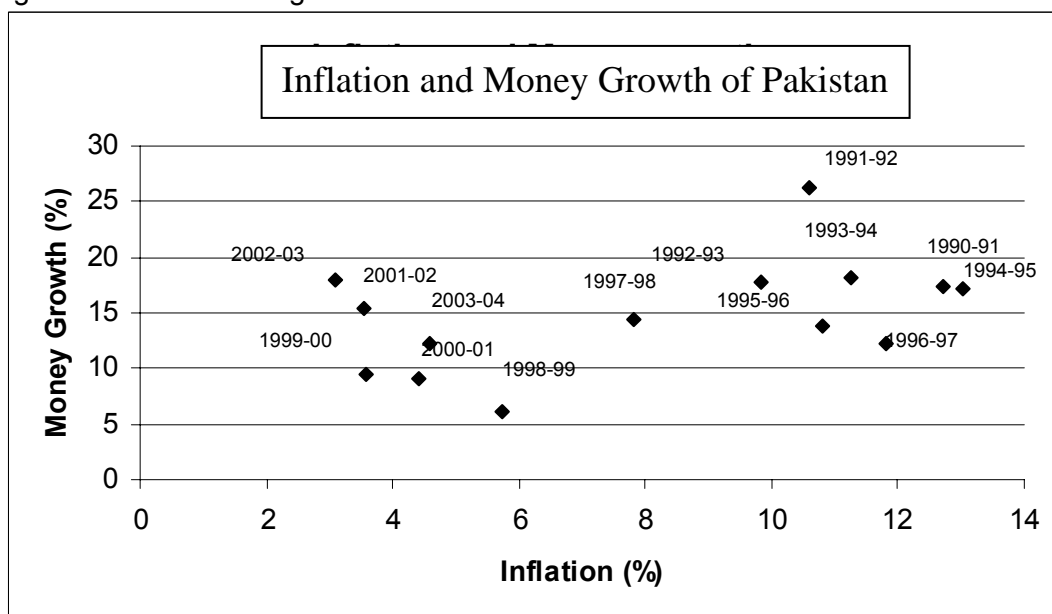

International data on inflation and money growth

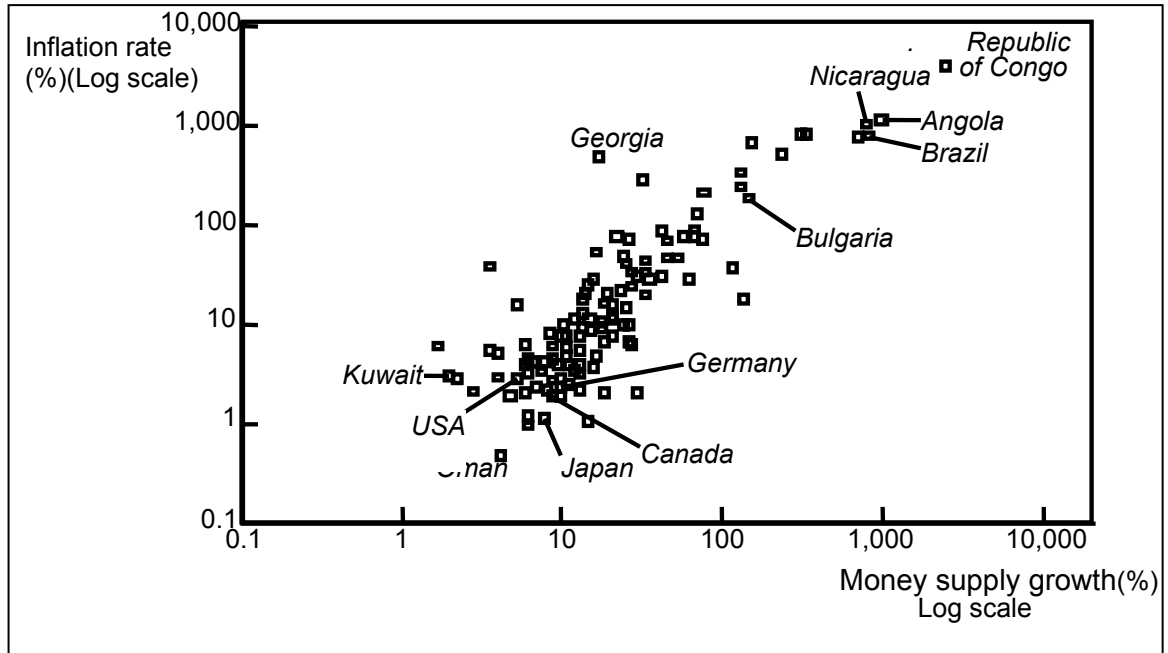

Inflation and Money growth in Pakistan

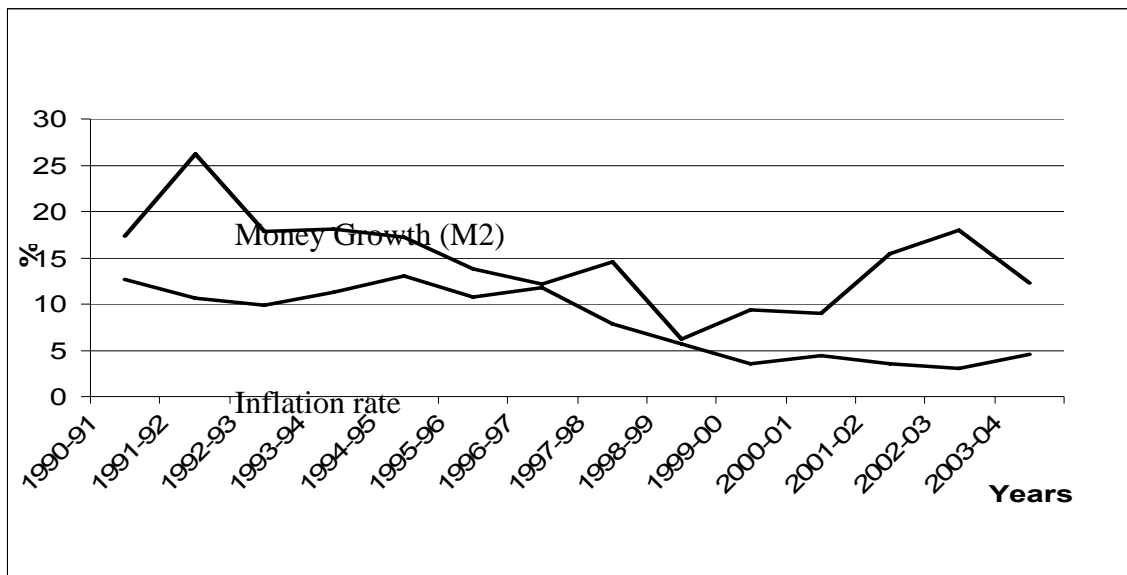

SEIGNIORAGE

- To spend more without raising taxes or selling bonds, the govt. can print money.
- The “revenue” raised from printing money is called seigniorage (pronounced SEEN-your-ige)
- The inflation tax:
Printing money to raise revenue causes inflation. Inflation is like a tax on people who hold money.

Inflation and interest rates

- Nominal interest rate, i
not adjusted for inflation
- Real interest rate, r
adjusted for inflation:
$$r = i - \pi$$

The Fisher Effect

- The Fisher equation:
$$i = r + \pi$$
- $S = I$ determines r .
- Hence, an increase in π causes an equal increase in i .
- This one-for-one relationship is called the Fisher effect.

MONEY AND INFLATION (Continued...)

The Fisher Effect

- The Fisher equation:

$$i = r + \pi$$

- $S = I$ determines r .
- Hence, an increase in π causes an equal increase in i .
- This one-for-one relationship is called the Fisher effect.

Exercise:

Suppose V is constant, M is growing 5% per year, Y is growing 2% per year, and $r = 4$.

- Solve for i (the nominal interest rate).
- If SBP increases the money growth rate by 2 percentage points per year, find Δi .
- If the growth rate of Y falls to 1% per year
- What will happen to π ?
- What must SBP do if it wishes to keep π constant?

Answers:

First, find $\pi = 5 - 2 = 3$.

Then, find $i = r + \pi = 4 + 3 = 7$.

- $\Delta i = 2$, same as the increase in the money growth rate.
- If SBP does nothing, $\Delta \pi = 1$.
To prevent inflation from rising, SBP must reduce the money growth rate by 1 percentage point per year.

Two real interest rates

- π = actual inflation rate
(not known until after it has occurred)
- π^e = expected inflation rate
- $i - \pi^e$ = **ex ante** real interest rate:
what people expect at the time they buy a bond or take out a loan
- $i - \pi$ = ex post real interest rate:
what people actually end up earning on their bond or paying on their loan

Money demand and the nominal interest rate

- The Quantity Theory of Money assumes that the demand for real money balances depends only on real income Y .
- We now consider another determinant of money demand: the nominal interest rate.
- The nominal interest rate i is the opportunity cost of holding money (instead of bonds or other interest-earning assets).

- Hence, $\uparrow i \Rightarrow \downarrow$ in money demand.

Linkages Among Money, Prices and Interest rate

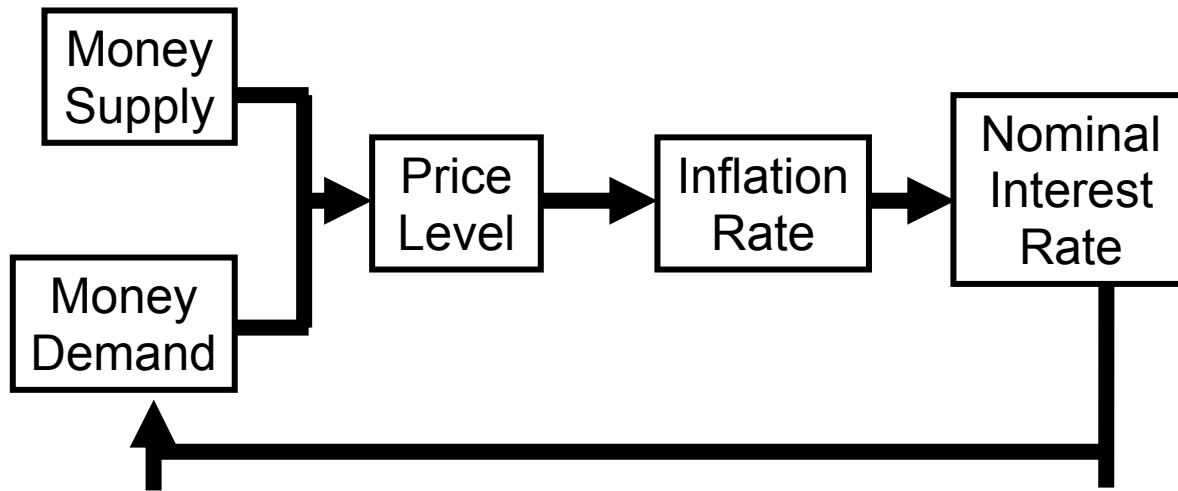

The money demand function

$$(M/P)^d = L(i, Y)$$

$(M/P)^d$ = real money demand, depends

- negatively on i
 i is the opportunity cost of holding money
- positively on Y
higher $Y \Rightarrow$ more spending so, need more money

(L is used for the money demand function because money is the most liquid asset.)

$$\begin{aligned} (M/P)^d &= L(i, Y) \\ &= L(r + \pi^e, Y) \end{aligned}$$

When people are deciding whether to hold money or bonds, they don't know what inflation will turn out to be.

Hence, the nominal interest rate relevant for money demand is $r + \pi^e$.

Equilibrium

$$\frac{M}{P} = L(r + \pi^e, Y)$$

Supply of Real money balances

Real money demand

What determines what

Variable how determined (in the long run)

M exogenous (SBP)

r adjusts to make $S = I$

Y $\bar{Y} = F(\bar{K}, \bar{L})$

P adjusts to make $\frac{M}{P} = L(i, Y)$

How P responds to ΔM

- For given values of r, Y, and π^e ,

a change in M causes P to change by the same percentage --- just like in the Quantity Theory of Money.

What about expected inflation?

- Over the long run, people don't consistently over- or under-forecast inflation, so $\pi^e = \pi$ on average.
- In the short run, π^e may change when people get new information.

EX: Suppose SBP announces it will increase M next year. People will expect next year's P to be higher, so π^e rises.

- This will affect P now, even though M hasn't changed yet.

How P responds to $\Delta \pi^e$

$$\frac{M}{P} = L(r + \pi^e, Y)$$

- For given values of r, Y, and M,

$$\uparrow \pi^e \Rightarrow \uparrow i \text{ (the Fisher effect)}$$

$$\Rightarrow \downarrow (M/P)^d$$

$$\Rightarrow \uparrow P \text{ to make } (M/P) \text{ fall}$$

to re-establish eq'm

The social costs of inflation

...fall into two categories:

1. Costs when inflation is expected
2. Additional costs when inflation is different than people had expected.

LESSON 13

MONEY AND INFLATION (Continued...)

Why is inflation bad?

- What costs does inflation impose on society? List all the ones you can think of.
- Focus on the long run.
- Think like an economist.

A common misperception

- Common misperception: inflation reduces real wages
- This is true only in the short run, when nominal wages are fixed by contracts.
- In the long run, the real wage is determined by labor supply and the marginal product of labor, not the price level or inflation rate.

The classical view of inflation

- The classical view:
A change in the price level is merely a change in the units of measurement.
So why, then, is inflation a social problem?

The social costs of inflation

The social costs of inflation fall into two categories:

1. Costs when inflation is expected
2. Additional costs when inflation is different than people had expected.

Costs of expected inflation:**1. Shoeleather cost**

- **def:** the costs and inconveniences of reducing money balances to avoid the inflation tax.
- $\uparrow \pi \Rightarrow \uparrow i$

$\Rightarrow \downarrow$ real money balances

- Remember: In long run, inflation doesn't affect real income or real spending.
- So, same monthly spending but lower average money holdings means more frequent trips to the bank to withdraw smaller amounts of cash.

2. Menu costs

- **def:** The costs of changing prices.
- Examples:

- Print new menus
- Print & mail new catalogs
- The higher is inflation, the more frequently firms must change their prices and incur these costs.

3. Relative price distortions

- Firms facing menu costs change prices infrequently.
- Example: Suppose a firm issues new catalog each January. As the general price level rises throughout the year, the firm's relative price will fall.
- Different firms change their prices at different times, leading to relative price distortions, which cause microeconomic inefficiencies in the allocation of resources

4. Unfair tax treatment

Some taxes are not adjusted to account for inflation, such as the capital gains tax.

Example:

- 1/1/2001: you bought Rs100, 000 worth of ABC stock
- 12/31/2001: you sold the stock for Rs110, 000, so your nominal capital gain was Rs10, 000 (10%).
- Suppose $\pi = 10\%$ in 2001. Your real capital gain is Rs 0.
- But the govt. requires you to pay taxes on your Rs1000 nominal gain!!

5. General inconvenience

- Inflation makes it harder to compare nominal values from different time periods.
- This complicates long-range financial planning.

Additional cost of unexpected inflation:

Arbitrary redistributions of purchasing power

- Many long-term contracts not indexed, but based on π^e .
- If π turns out different from π^e , then some gain at others' expense.
Example: borrowers & lenders
 - If $\pi > \pi^e$, then $(r - \pi) < (r - \pi^e)$ and purchasing power is transferred from lenders to borrowers.
 - If $\pi < \pi^e$, then purchasing power is transferred from borrowers to lenders.

Additional cost of high inflation:

Increased uncertainty

- When inflation is high, it's more variable and unpredictable: π turns out different from π^e more often, and the differences tend to be larger (though not systematically positive or negative)

- Arbitrary redistributions of wealth become more likely.
- This creates higher uncertainty, which makes risk averse people worse off.

One benefit of inflation

- Nominal wages are rarely reduced, even when the equilibrium real wage falls.
- Inflation allows the real wages to reach equilibrium levels without nominal wage cuts.
- Therefore, moderate inflation improves the functioning of labor markets.

Hyperinflation

- def: $\pi \geq 50\%$ per month
- All the costs of moderate inflation described above become HUGE under hyperinflation.
- Money ceases to function as a store of value, and may not serve its other functions (unit of account, medium of exchange).
- People may conduct transactions with barter or a stable foreign currency.

What causes hyperinflation?

- Hyperinflation is caused by excessive money supply growth:
- When the central bank prints money, the price level rises.
- If it prints money rapidly enough, the result is hyperinflation.

Why governments create hyperinflation

- When a government cannot raise taxes or sell bonds,
- it must finance spending increases by printing money.
- In theory, the solution to hyperinflation is simple: stop printing money.
- In the real world, this requires drastic and painful fiscal restraint.

MONEY AND INFLATION (Continued...)

The Classical Dichotomy

Real variables are measured in physical units: quantities and relative prices, e.g.

- Quantity of output produced
- Real wage: output earned per hour of work
- Real interest rate: output earned in the future by lending one unit of output today

Nominal variables: measured in money units, e.g.

- Nominal wage: dollars per hour of work
- Nominal interest rate: dollars earned in future by lending one dollar today
- The price level: the amount of dollars needed to buy a representative basket of goods

- **Classical Dichotomy:**

“The theoretical separation of real and nominal variables in the classical model, which implies nominal variables do not affect real variables. “

- **Neutrality of Money:**

Changes in the money supply do not affect real variables. In the real world, money is approximately neutral in the long run.

The Open Economy

- Accounting identities for the open economy
- Small open economy model
 - What makes it “small”
 - How the trade balance and exchange rate are determined
 - How policies affect trade balance & exchange rate

Imports and Exports as a percentage of output

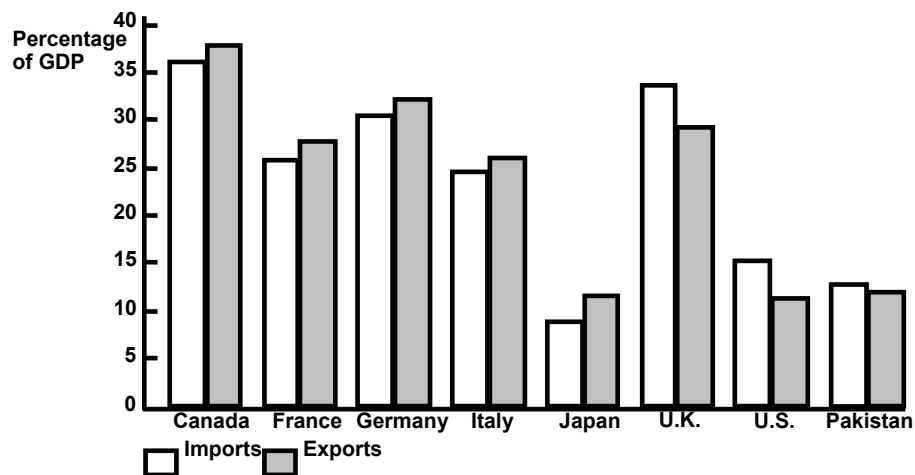

In an open economy:

- Spending need not equal output
- Saving need not equal investment

Preliminaries

$$C = C^d + C^f$$

$$I = I^d + I^f$$

$$G = G^d + G^f$$

Superscripts:

d = spending on domestic goods

f = spending on foreign goods

EX = exports = foreign spending on domestic goods

IM = imports = $C^f + I^f + G^f$ = spending on foreign goods

NX = net exports (the “trade balance”)
= EX – IM

- If $NX > 0$, country has a trade surplus equal to NX
- If $NX < 0$, country has a trade deficit equal to – NX

GDP = expenditure on domestically produced goods & services

$$\begin{aligned} Y &= C^d + I^d + G^d + EX \\ &= (C - C^f) + (I - I^f) + (G - G^f) + EX \\ &= C + I + G + EX - (C^f + I^f + G^f) \\ &= C + I + G + EX - IM \\ &= C + I + G + NX \end{aligned}$$

The national income identity in an open economy

$$Y = C + I + G + NX$$

Or, $NX = Y - (C + I + G)$

Where,

NX => Net Export

Y => Output

$C + I + G$ => Domestic Spending

Net Foreign Investment and Trade Balance

- We have

$$Y = C + I + G + NX$$

Re-arranging;

$$Y - C - G = I + NX$$

- Recall, $Y - C - G$ is national savings S ,
the sum of private savings ($Y - T - C$) and public savings ($T - G$).

Hence;

$$S = I + NX$$

or $S - I = NX$

- $S - I$ is the difference between domestic saving and domestic investment, referred to as Net Foreign Investment
- While NX is the Trade Balance
- So

$$\text{Net Foreign Investment} = \text{Trade Balance}$$

$$S - I = NX$$

International capital flows

- Net capital outflows
= $S - I$
= net outflow of "loanable funds"
= net purchases of foreign assets
 - Net capital outflows
the country's purchases of foreign assets minus foreign purchases of domestic assets
- When $S > I$, country is a net lender
- When $S < I$, country is a net borrower
- An open-economy version of the loanable funds model includes many of the same elements:

Saving and Investment in a Small Open Economy

production function: $Y = \bar{Y} = F(\bar{K}, \bar{L})$

consumption function: $C = C(Y - T)$

investment function: $I = I(r)$

exogenous policy variables: $G = \bar{G}, T = \bar{T}$

National Saving: The Supply of Loanable Funds

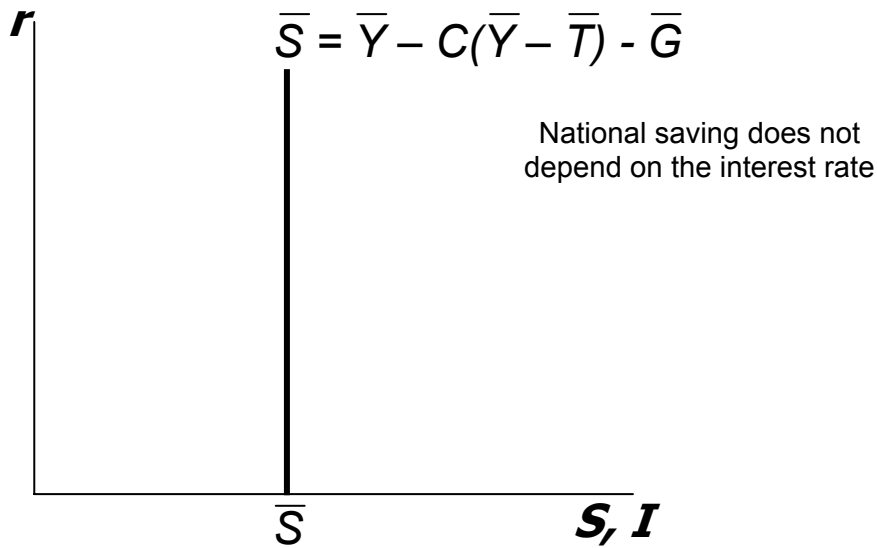

Assumptions: capital flows

- Domestic & foreign bonds are perfect substitutes
- Perfect capital mobility:
no restrictions on international trade in assets
- Economy is small:
cannot affect the world interest rate, denoted r^*

Investment: Demand for Loanable Funds

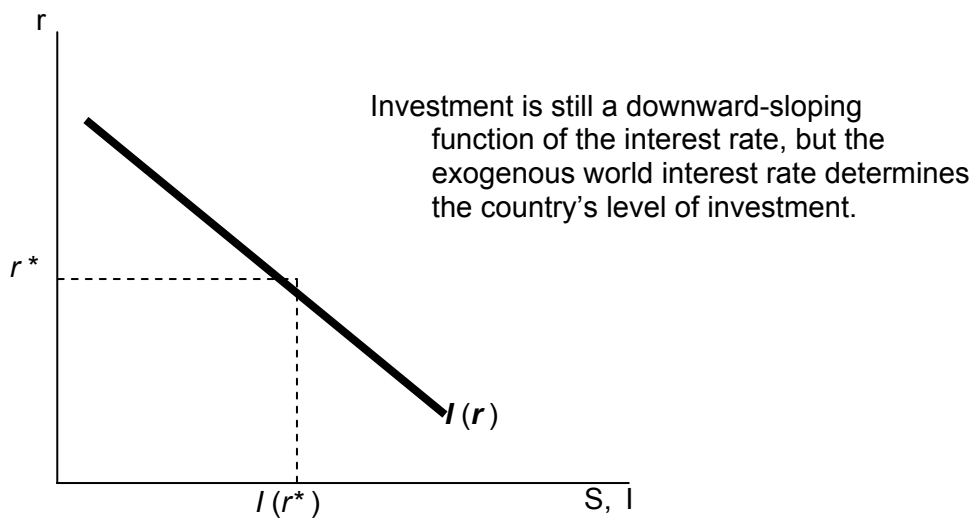

Closed Economy

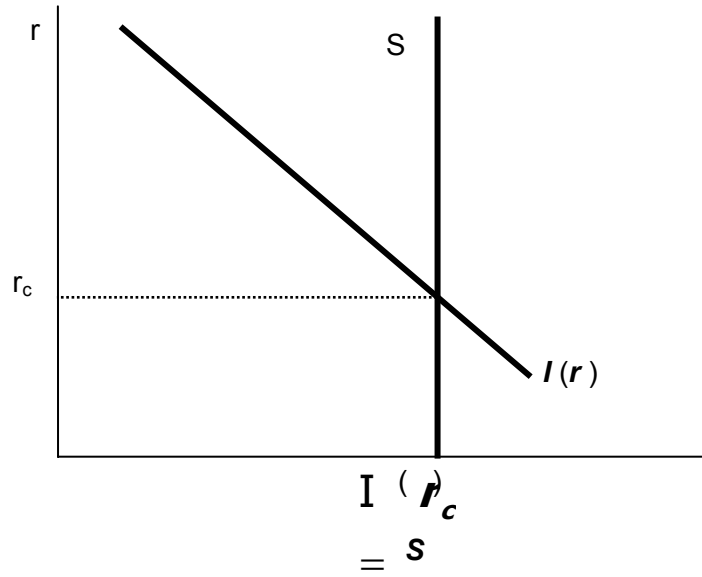

...the interest rate would adjust to equate investment and saving:

A Small Open Economy

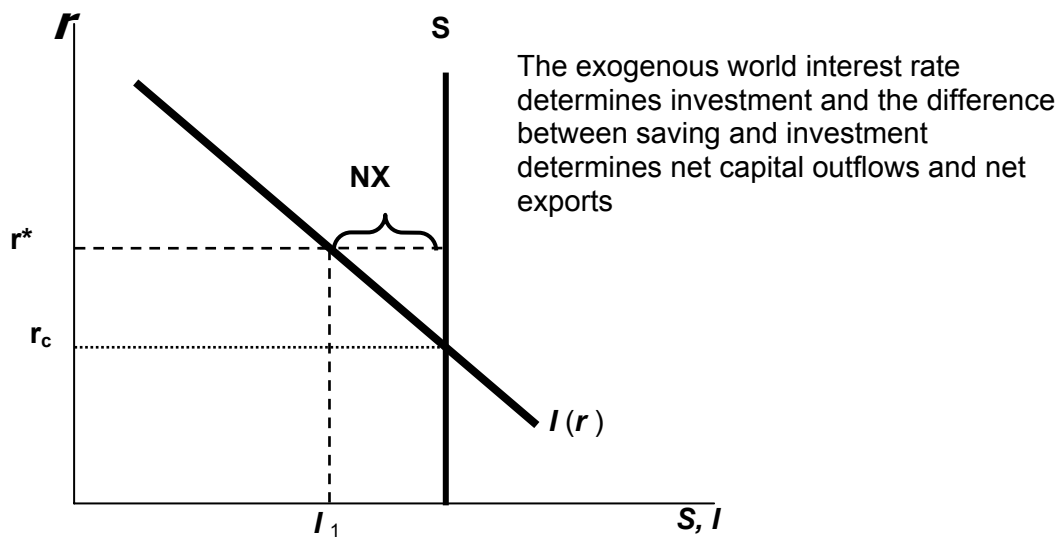

OPEN ECONOMY

Three experiments

1. Fiscal policy at home
2. Fiscal policy abroad
3. An increase in investment demand

1. Fiscal policy at home

An increase in G or decrease in T reduces saving.

Results:

$$\Delta I = 0$$

$$\Delta NX = \Delta S < 0$$

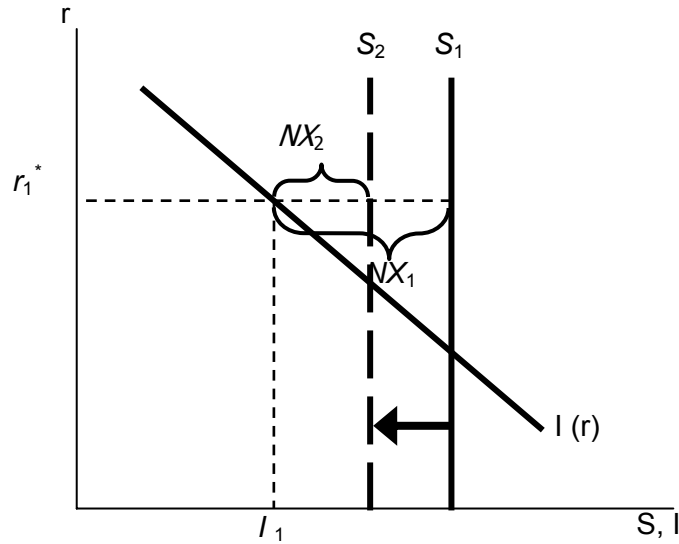

NX and the Govt. Budget Deficit

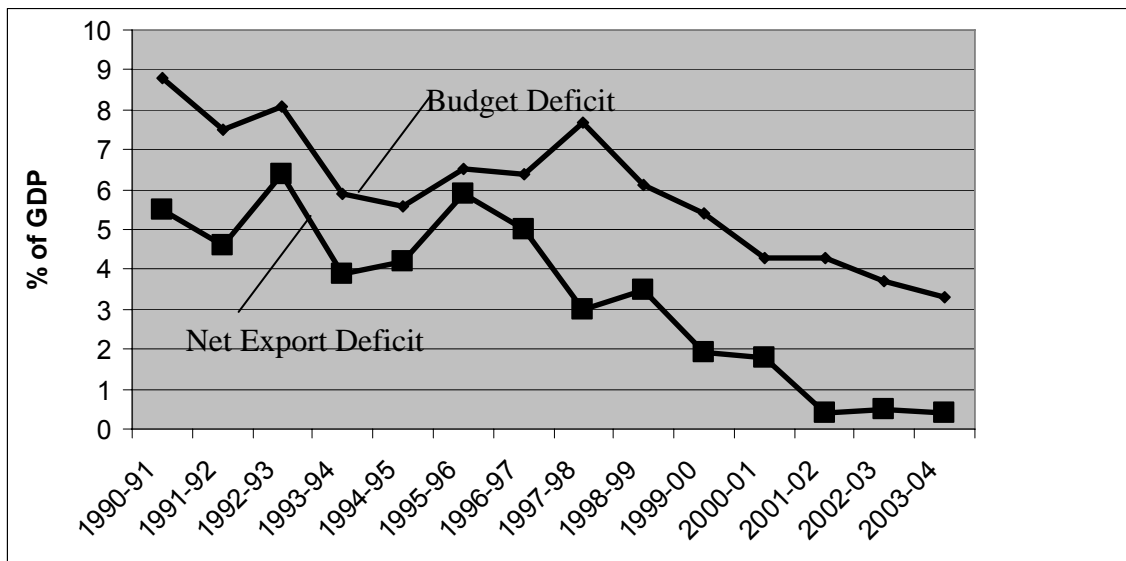

2. Fiscal policy abroad

Expansionary fiscal policy abroad raises the world interest rate.

Results:

$$\Delta I < 0$$

$$\Delta NX = -\Delta I > 0$$

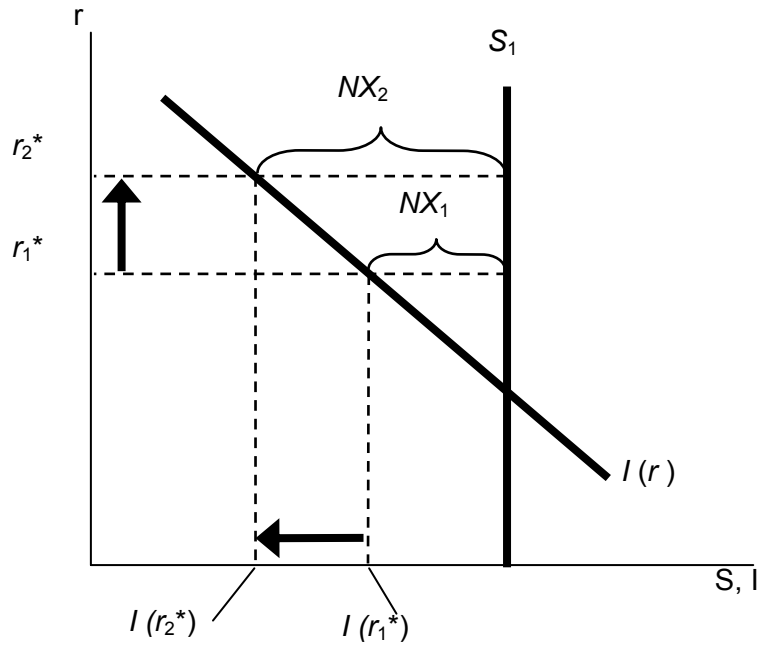

3. An increase in investment demand

$\Delta I > 0,$
 $\Delta S = 0,$
 net capital outflows and net exports fall by the amount ΔI

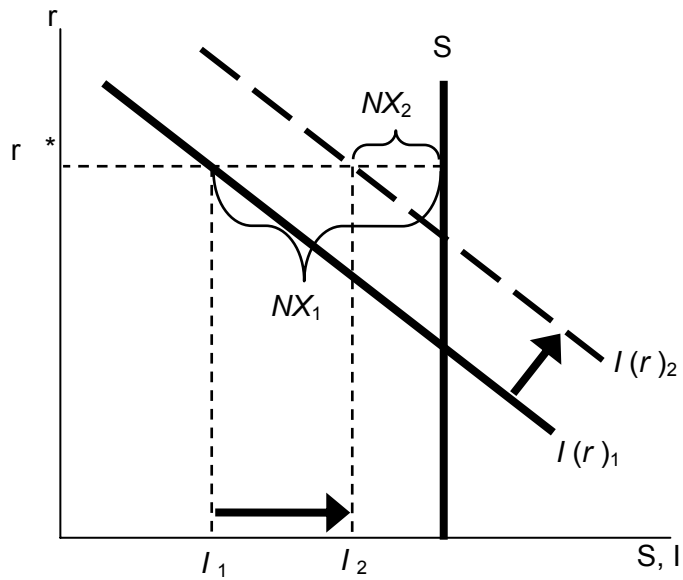

The nominal exchange rate

e = nominal exchange rate, the relative price of domestic currency in terms of foreign currency (e.g. Yen per Dollar)

Exchange rates as of February 26, 2005

<i>Country</i>	<i>Currency</i>	<i>exchange rate</i>
Europe	Euro(€)	Rs. 78.53
Japan	Yen(¥)	Rs. 0.5642
U.K.	Pound(£)	Rs. 113.99
United States	Dollar(\$)	Rs. 59.32
UAE	Dirham	Rs. 16.15

The real exchange rate

ε = real exchange rate, the relative price of domestic goods in terms of foreign goods (e.g. Japanese Big Macs per U.S. Big Mac)

Understanding the units of ε

$$\begin{aligned}
 \mathcal{E} &= \frac{e \times P}{P^*} \\
 &= \frac{(\text{Yen per } \$) \times (\$ \text{ per unit U.S. goods})}{\text{Yen per unit Japanese goods}} \\
 &= \frac{\text{Yen per unit U.S. goods}}{\text{Yen per unit Japanese goods}} \\
 &= \frac{\text{Units of Japanese goods}}{\text{per unit of U.S. goods}}
 \end{aligned}$$

~ Example ~

- One good: Burger
- Price in Japan: $P^* = 200$ Yen
- Price in USA: $P = \$2.50$
- Nominal exchange rate, $e = 120$ Yen/\$

$$\begin{aligned}
 \mathcal{E} &= \frac{e \times P}{P^*} \\
 &= \frac{120 \times \$2.50}{200 \text{ Yen}} = 1.5
 \end{aligned}$$

To buy a U.S. burger, someone from Japan would have to pay an amount that could buy 1.5 Japanese Burgers.

ϵ in the real world & our model

- In the real world:
We can think of ϵ as the relative price of a basket of domestic goods in terms of a basket of foreign goods
- In our macro model:
There's just one good, "output." So ϵ is the relative price of one country's output in terms of the other country's output

How NX depends on ϵ

$\uparrow\epsilon \Rightarrow$ US goods become more expensive relative to foreign goods

$\Rightarrow \downarrow EX, \uparrow IM$

$\Rightarrow \downarrow NX$

OPEN ECONOMY (Continued...)

How ϵ is determined

- The accounting identity says $NX = \bar{S} - I$
- We saw earlier how $\bar{S} - I$ is determined:
- S depends on domestic factors (output, fiscal policy variables, etc)
- I is determined by the world interest rate r^*
- So, ϵ must adjust to ensure

$$NX(\epsilon) = \bar{S} - I(r^*)$$

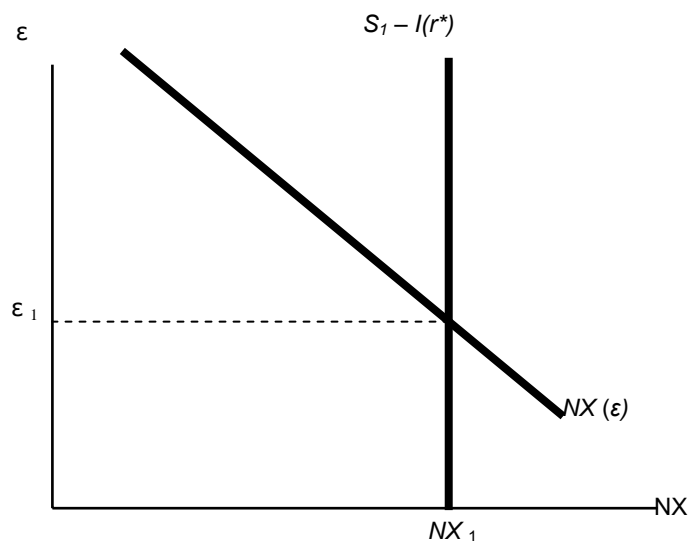

Neither S nor I depend on ϵ , so the net capital outflow curve is vertical. ϵ adjusts to equate NX with net capital outflow, $S - I$.

Supply and demand in foreign exchange market

Demand: Foreigners need dollars to buy U.S. net exports.

Supply: The net capital outflow ($S - I$) is the supply of dollars to be invested abroad.

The net exports function

- The net exports function reflects this inverse relationship between NX and ϵ :

$$NX = NX(\epsilon)$$

The NX curve

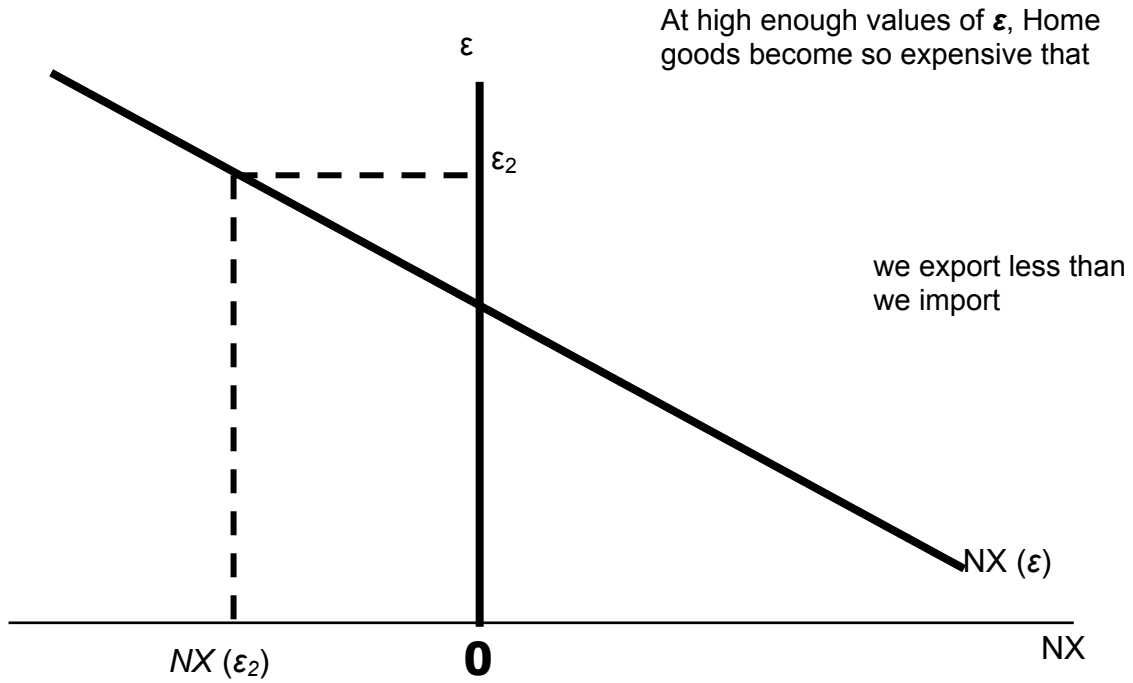
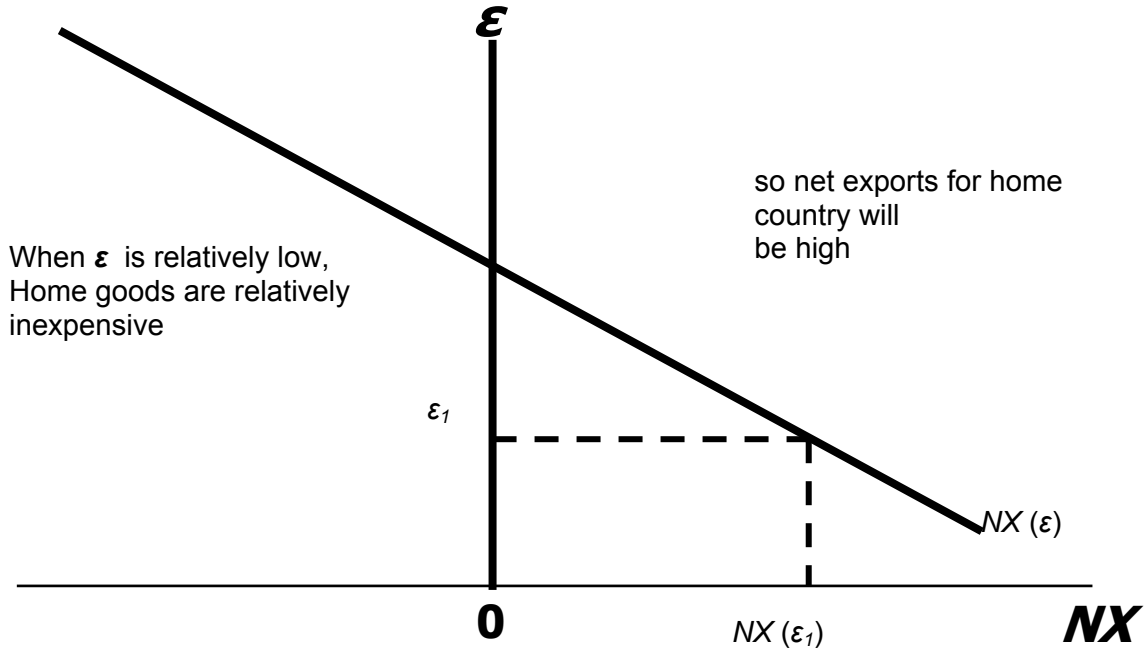

Four experiments

1. Fiscal policy at home
2. Fiscal policy abroad
3. An increase in investment demand
4. Trade policy to restrict imports

1. Fiscal policy at home

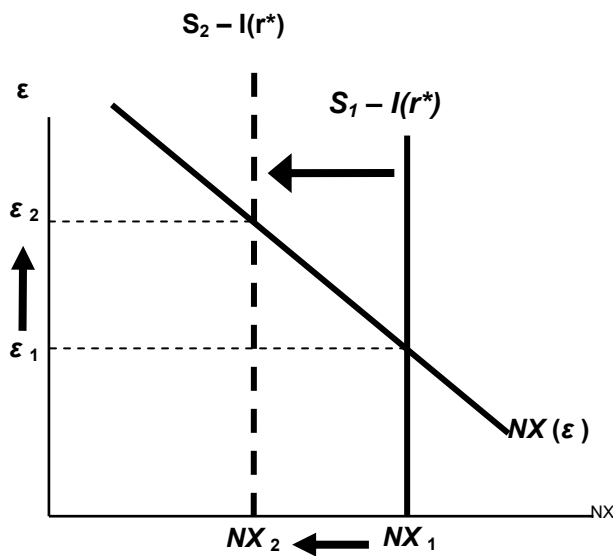

A fiscal expansion reduces national saving, net capital outflows, and the supply of dollars in the foreign exchange market causing the real exchange rate to rise and NX to fall.

2. Fiscal policy abroad

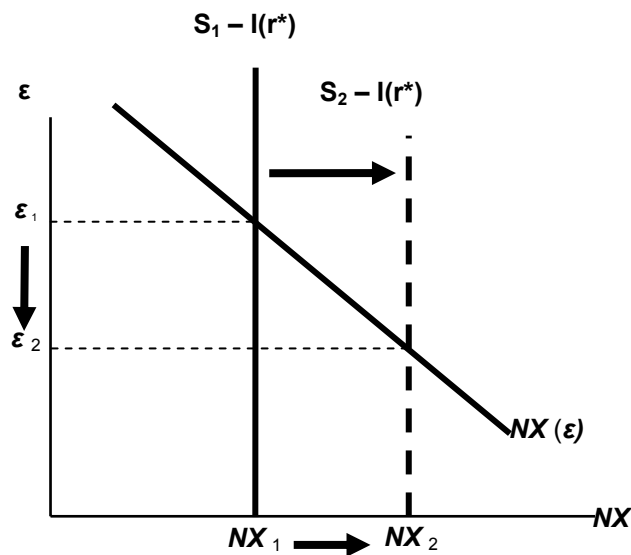

An increase in r^* reduces investment increasing net capital outflows and the supply of dollars in the foreign exchange market causing the real exchange rate to fall and NX to rise.

3. An increase in investment demand

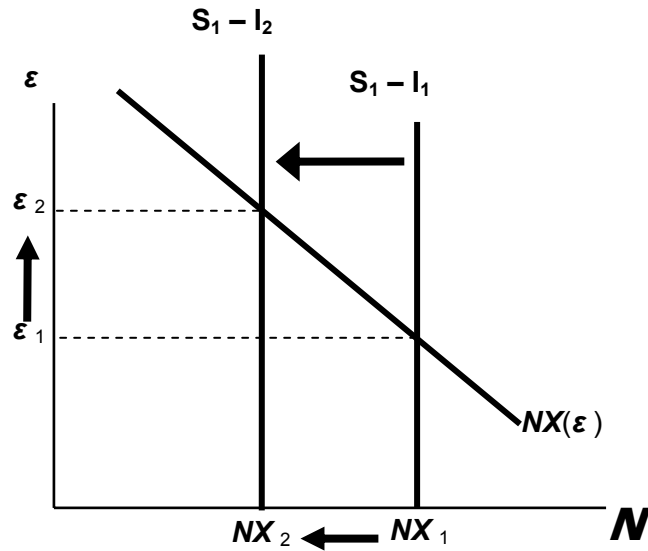

An increase in investment reduces net capital outflows and the supply of dollars in the foreign exchange market causing the real exchange rate to rise and NX to fall.

4. Trade policy to restrict imports

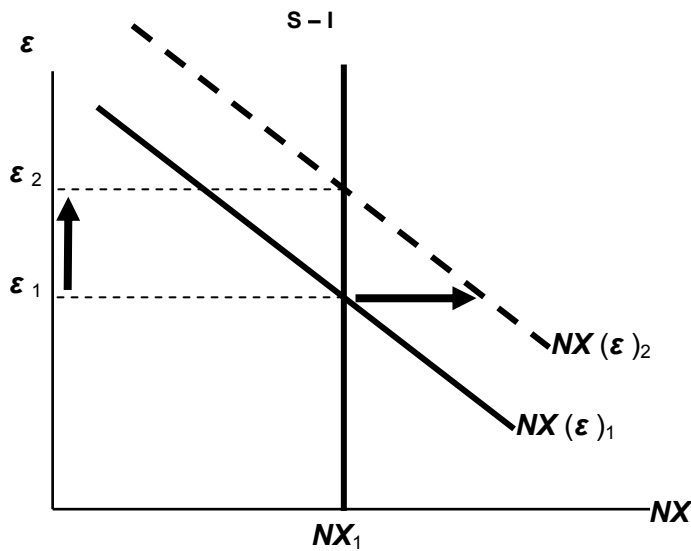

At any given value of ϵ , an import quota

$$\downarrow \text{IM} \rightarrow \uparrow \text{NX}$$

demand for dollars shifts right. Trade policy doesn't affect S or I, so capital flows and the supply of dollars remains fixed.

Results:

$$\Delta \epsilon > 0 \text{ (demand increase)}$$

$$\Delta \text{NX} = 0 \text{ (supply fixed)}$$

$$\Delta \text{IM} < 0 \text{ (policy)}$$

$$\Delta \text{EX} < 0 \text{ (rise in } \epsilon \text{)}$$

The Determinants of the Nominal Exchange Rate

- Start with the expression for the real exchange rate:

$$\epsilon = \frac{e \times P}{P^*}$$

- Solve it for the nominal exchange rate:

$$e = \epsilon \times \frac{P^*}{P}$$

- So e depends on the real exchange rate and the price levels at home and abroad...
- ...and we know how each of them is determined:

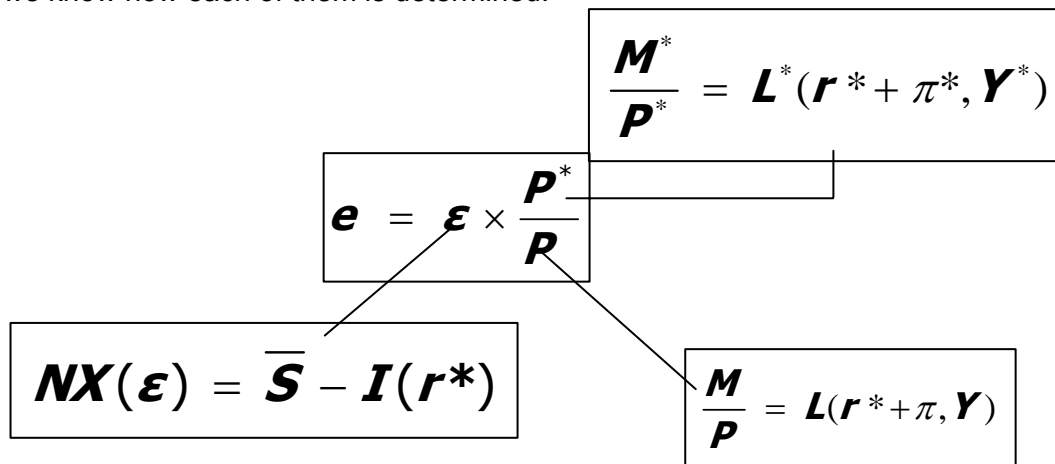

- We can rewrite this equation in terms of growth rates

$$\frac{\Delta e}{e} = \frac{\Delta \epsilon}{\epsilon} + \frac{\Delta P^*}{P^*} - \frac{\Delta P}{P} = \frac{\Delta \epsilon}{\epsilon} + \pi^* - \pi$$

Inflation and nominal exchange rates

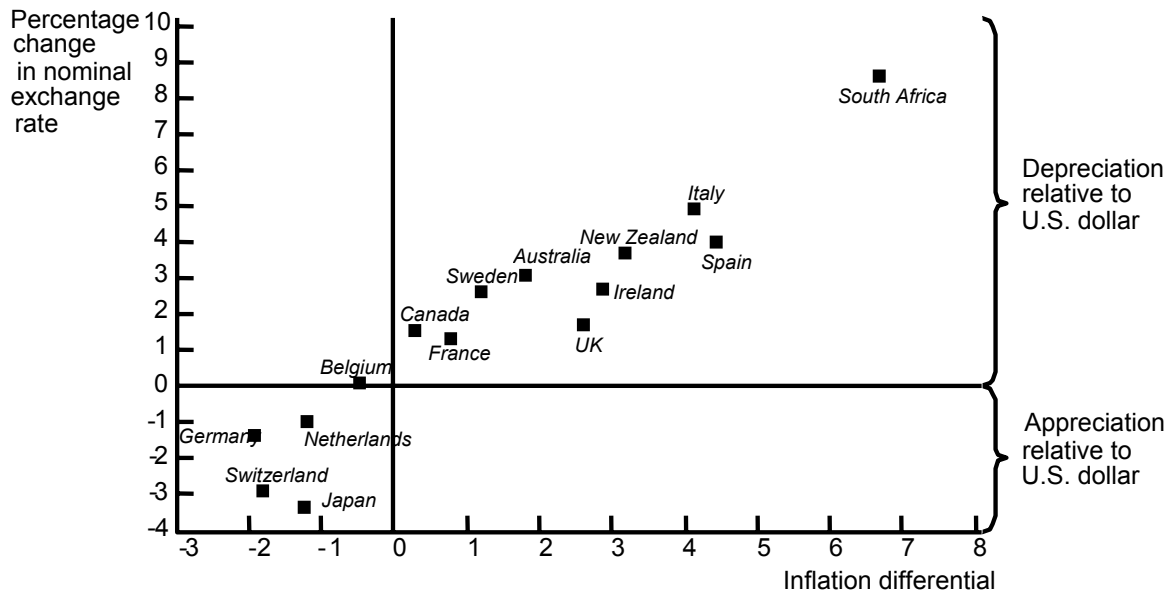

OPEN ECONOMY (Continued...)

Purchasing Power Parity (PPP)

- *def1*: a doctrine that states that goods must sell at the same (currency-adjusted) price in all countries.
- *def2*: the nominal exchange rate adjusts to equalize the cost of a basket of goods across countries.
- Reasoning: arbitrage, the law of one price
- PPP: $e \times P = P^*$

Where

$e \times P$ - Cost of a basket of domestic goods, in foreign currency.

P - Cost of a basket of domestic goods, in domestic currency.

P^* - Cost of a basket of foreign goods, in foreign currency.

Solve for e : $e = P^*/P$

PPP implies that the nominal exchange rate between two countries equals the ratio of the countries' price levels.

$$\epsilon = e \times \frac{P}{P^*} = \frac{P^*}{P} \times \frac{P}{P^*} = 1$$

- If $e = P^*/P$,
then

Does PPP hold in the real world?

No, for two reasons:

1. International arbitrage not possible.
 - Non traded goods
 - Transportation costs
2. Goods of different countries not perfect substitutes.

Nonetheless, PPP is a useful theory:

- It's simple & intuitive
- In the real world, nominal exchange rates have a tendency toward their PPP values over the long run.

Issues in Unemployment

The natural rate of unemployment:

- What it means
- What causes it
- Understanding its behavior in the real world

Natural Rate of Unemployment

- Natural rate of unemployment:
the average rate of unemployment around which the economy fluctuates.
- In a recession, the actual unemployment rate rises above the natural rate.
- In a boom, the actual unemployment rate falls below the natural rate.

Unemployment Rate of Pakistan

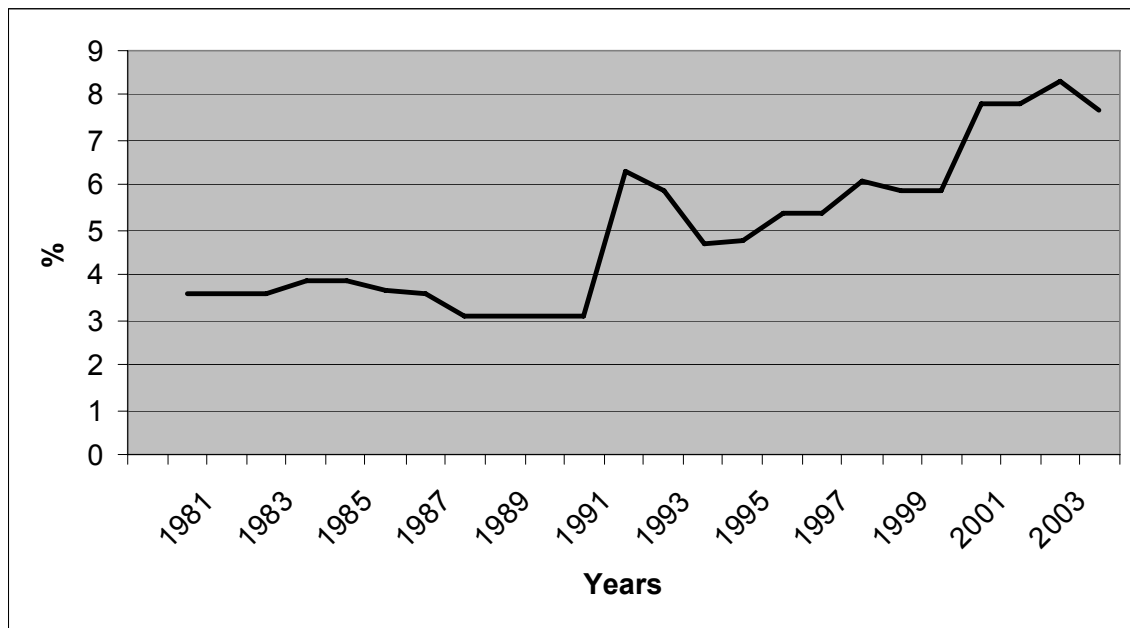

A first model of the natural rate

Notation:

L = # of workers in labor force

E = # of employed workers

U = # of unemployed

U/L = unemployment rate

Assumptions:

1. L is exogenously fixed.

2. During any given month,

s = fraction of employed workers that become separated from their jobs,

f = fraction of unemployed workers that find jobs.

s = rate of job separations, f = rate of job finding (*both exogenous*)

Transitions between employment and unemployment

The steady state condition

- Definition: the labor market is in steady state, or long-run equilibrium, if the unemployment rate is constant.
- The steady-state condition is:

$$s \times E = f \times U$$

number of employed people who lose or leave their jobs = number of unemployed people who find jobs

Solving for the “equilibrium” U rate

$$\begin{aligned}
 f \times U &= s \times E \\
 &= s \times (L - U) \\
 &= s \times L - s \times U
 \end{aligned}$$

Solve for U/L:

$$(f + s) \times U = s \times L$$

$$\frac{U}{L} = \frac{s}{s + f}$$

So,

Example:

- Each month, 1% of employed workers lose their jobs ($s = 0.01$)
- Each month, 19% of unemployed workers find jobs ($f = 0.19$)
- Find the natural rate of unemployment:

$$\frac{U}{L} = \frac{s}{s + f} = \frac{0.01}{0.01 + 0.19} = 0.05, \text{ or } 5\%$$

Policy implication

- A policy that aims to reduce the natural rate of unemployment will succeed only if it lowers s or increases f .

Why is there unemployment?

- If job finding were instantaneous ($f = 1$), then all spells of unemployment would be brief, and the natural rate would be near zero.
- There are two reasons why $f < 1$:
 1. Job search
 2. Wage rigidity

Job Search & Frictional Unemployment

- Frictional unemployment: caused by the time it takes workers to search for a job
- Occurs even when wages are flexible and there are enough jobs to go around

Job Search & Frictional Unemployment

Occurs because

- Workers have different abilities, preferences
- Jobs have different skill requirements
- Geographic mobility of workers not instantaneous
- Flow of information about vacancies and job candidates is imperfect

ISSUES IN UNEMPLOYMENT

Sectoral shifts

- def: changes in the composition of demand among industries or regions
- Example#1 Technological change
increases demand for computer repair persons, decreases demand for typewriter repair persons

Example#2 A new international trade agreements cause greater demand for workers in the export sectors and less demand for workers in import-competing sectors.

- It takes time for workers to change sectors, so sectoral shifts cause frictional unemployment.

Industry shares in GDP, 1969-70

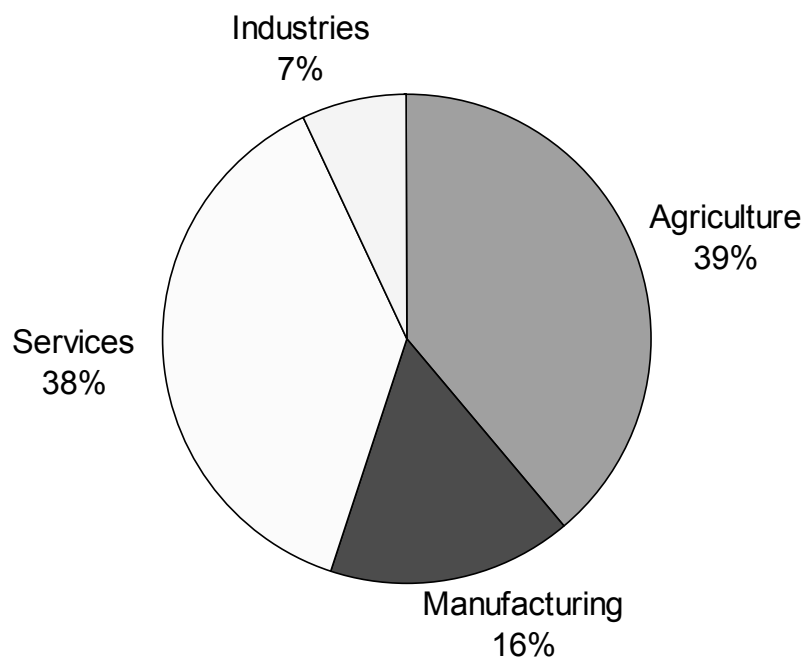

Industry shares in GDP, 2003-04

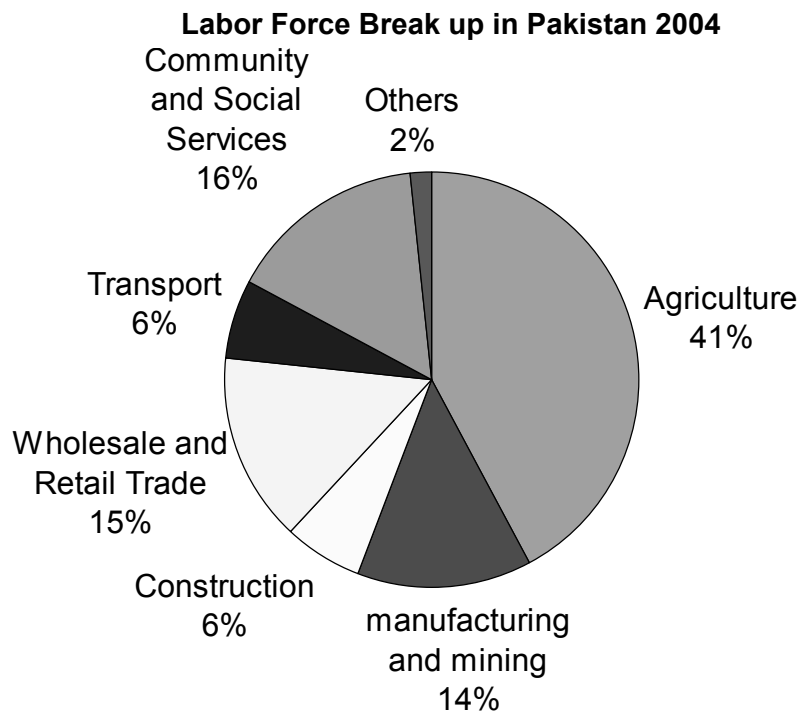
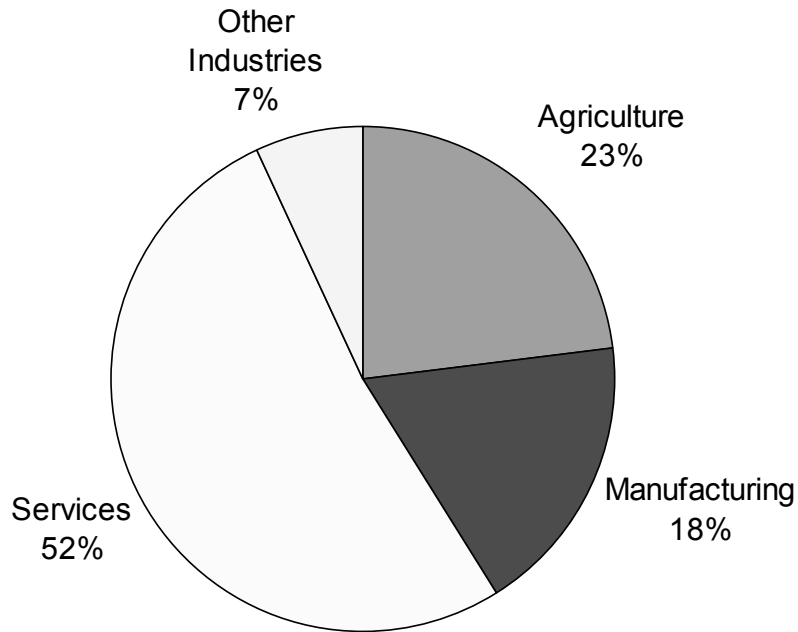

Sectoral shifts abound

- In our dynamic economy, smaller (though still significant) sectoral shifts occur frequently, contributing to frictional unemployment.

Public Policy and Job Search

Govt programs affecting unemployment

- Govt employment agencies: disseminate info about job openings to better match workers & jobs
- Public job training programs: help workers displaced from declining industries get skills needed for jobs in growing industries

Unemployment insurance (UI)

- UI pays part of a worker’s former wages for a limited time after losing his/her job.
- UI increases search unemployment, because it:
 - reduces the opportunity cost of being unemployed
 - reduces the urgency of finding work
 - hence, reduces f
- Studies: The longer a worker is eligible for UI, the longer the duration of the average spell of unemployment.

Benefits of UI

- By allowing workers more time to search, I may lead to better matches between jobs and workers, which would lead to greater productivity and higher incomes.

Why is there unemployment?

The natural rate of unemployment:
$$\frac{U}{L} = \frac{s}{s + f}$$

- There are two reasons why $f < 1$:
 1. Job search
 2. Wage rigidity

Unemployment from real wage rigidity

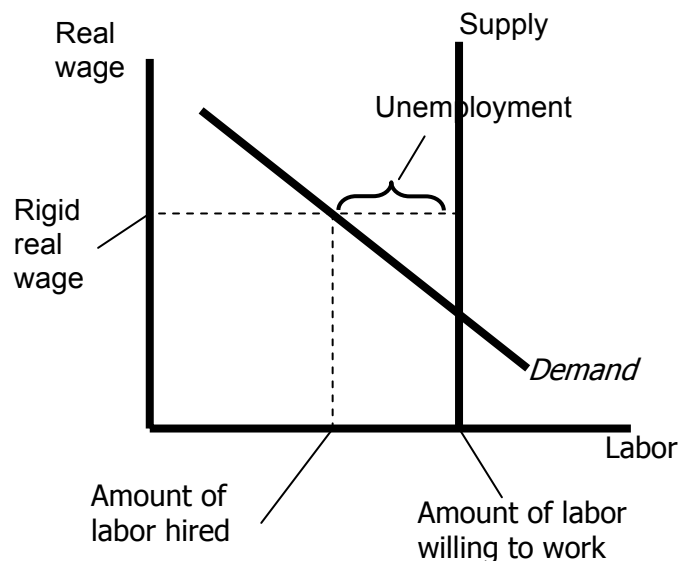

If the real wage is stuck above the equilibrium level, then there aren't enough jobs to go around. Then, firms must ration the scarce jobs among workers.

Structural unemployment: the unemployment resulting from real wage rigidity and job rationing.

Reasons for wage rigidity

1. Minimum wage laws
2. Labor unions
3. Efficiency wages

The minimum wage

- The minimum wage is well below the equilibrium wage for most workers, so it cannot explain the majority of natural rate unemployment.
- However, the minimum wage may exceed the equilibrium wage of unskilled workers, especially teenagers.
- If so, then we would expect that increases in the minimum wage would increase unemployment among these groups.

The minimum wage in the real world:

- In Sept 1996, the minimum wage was raised from \$4.25 to \$4.75 in US.

Unemployment rates, before & after		
	3rd Q 1996	1st Q 1997
Teenagers	16.6%	17.0%
Single mothers	8.5%	9.1%
All workers	5.3%	5.3%

- Other studies: A 10% increase in the minimum wage increases teenage unemployment by 1-3%.

Labor unions

- Unions exercise monopoly power to secure higher wages for their members.
- When the union wage exceeds the equilibrium wage, unemployment results.
- Employed union workers are insiders whose interest is to keep wages high.
- Unemployed non-union workers are outsiders and would prefer wages to be lower (so that labor demand would be high enough for them to get jobs).

Efficiency Wage Theory

- Theories in which high wages increase worker productivity:
 - Attract higher quality job applicants

- Increase worker effort and reduce “shirking”
- Reduce turnover, which is costly
- Improve health of workers (*in developing countries*)
- The increased productivity justifies the cost of paying above-equilibrium wages.
- The result: unemployment

The duration of unemployment

- The data:
 - More spells of unemployment are short-term than medium-term or long-term.
 - Yet, most of the total time spent unemployed is attributable to the long-term unemployed.
- This long-term unemployment is probably structural and/or due to sectoral shifts among vastly different industries.
- Knowing this is important because it can help us craft policies that are more likely to succeed.

Unemployment Rate of Pakistan

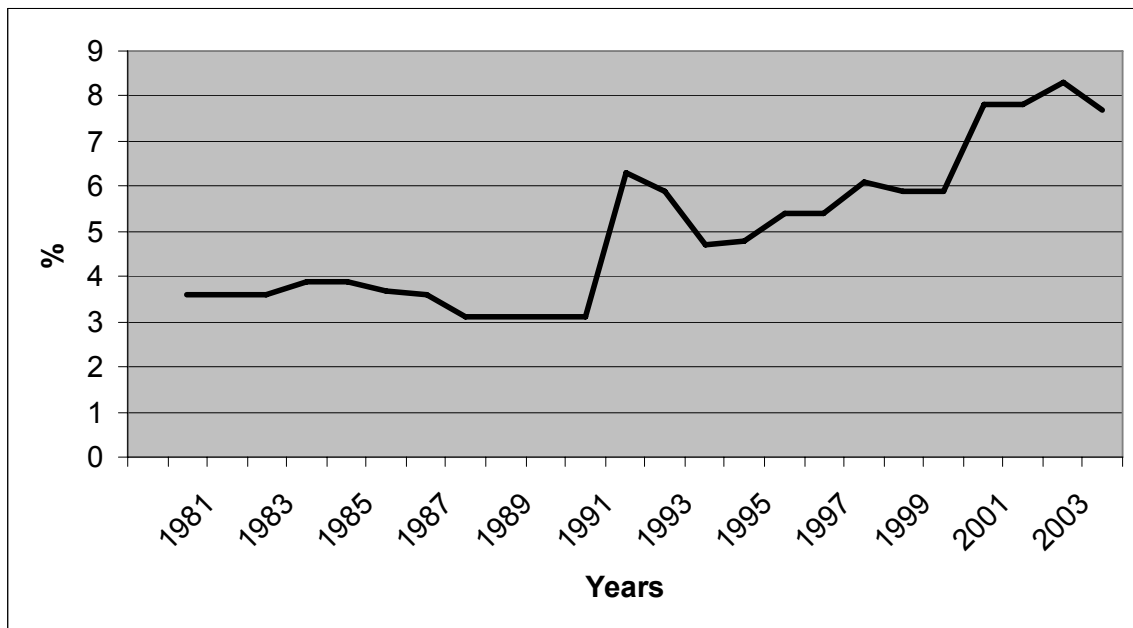

The rise in European Unemployment

Two explanations:

1. Most countries in Europe have generous social insurance programs.
2. Shift in demand from unskilled to skilled workers, due to technological change.

This demand shift occurred in the U.S., too. But wage rigidity is less of a problem here, so the shift caused an increase in the skilled-to-unskilled wage gap instead of increase in unemployment

ECONOMIC GROWTH

Issues in Economic Growth

- Learn the closed economy Solow model
- See how a country's standard of living depends on its saving and population growth rates
- Learn how to use the "Golden Rule" to find the optimal savings rate and capital stock

Per Capita Income of Selected Countries, 2004 (in US \$)

Norway	43,350	Saudi Arabia	8,530
Switzerland	39,880	Mexico	6,230
United States	37,610	Malaysia	3,780
Japan	34,510	Brazil	2,710
United Kingdom	28,350	Russia	2,610
Belgium	25,820	Egypt	1,390
Germany	25,250	China	1,100
France	24,770	Indonesia	810
Australia	21,650	India	530
Italy	21,560	Pakistan	470
Kuwait	16,340	Bangladesh	400
Korea	12,020	Nigeria	320

THE SOLOW MODEL

- Due to Robert Solow, won Nobel Prize for contributions to the study of economic growth
- A major paradigm:
 - Widely used in policy making
 - Benchmark against which most recent growth theories are compared
- Looks at the determinants of economic growth and the standard of living in the long run
- The **Solow Growth Model** is designed to show how growth in the capital stock, growth in the labor force, and advances in technology interact in an economy, and how they affect a nation's total output of goods and services.

How Solow model is different

1. K is no longer fixed: investment causes it to grow, depreciation causes it to shrink.
2. L is no longer fixed: population growth causes it to grow.
3. The consumption function is simpler.
4. No **G** or **T** (only to simplify presentation; we can still do fiscal policy experiments)
5. Cosmetic differences.

The production function

Let's analyze the supply and demand for goods, and see how much output is produced at any given time and how this output is allocated among alternative uses.

The production function represents the transformation of **inputs** (labor (L), capital (K), and production technology) into **outputs** (final goods and services for a certain time period).

- In aggregate terms: $Y = F(K, L)$
- Define: $y = Y/L =$ output per worker
 $k = K/L =$ capital per worker
- Assume constant returns to scale:
 $zY = F(zK, zL)$ for any $z > 0$
- Pick $z = 1/L$. Then
 $Y/L = F(K/L, 1)$
 $y = F(k, 1)$
 $y = f(k)$ where $f(k) = F(k, 1)$

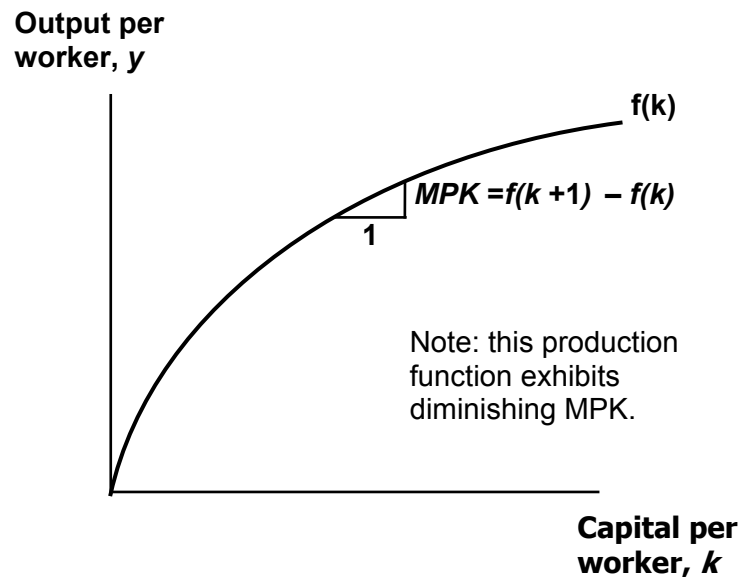

The national income identity

- $Y = C + I$ (remember, no **G**)

- In “per worker” terms:
 $y = c + i$
 where $c = C/L$ and $i = I/L$

The consumption function

- s = the saving rate, the fraction of income that is saved (s is an exogenous parameter)
- Note: s is the only lowercase variable that is not equal to its uppercase version divided by L
- Consumption function: $c = (1-s)y$ (per worker)

Saving and investment

- saving (per worker) = sy
- National income identity is $y = c + i$
 Rearrange to get: $i = y - c = sy$ (investment = saving)
- Using the results above,
 $i = sy = sf(k)$

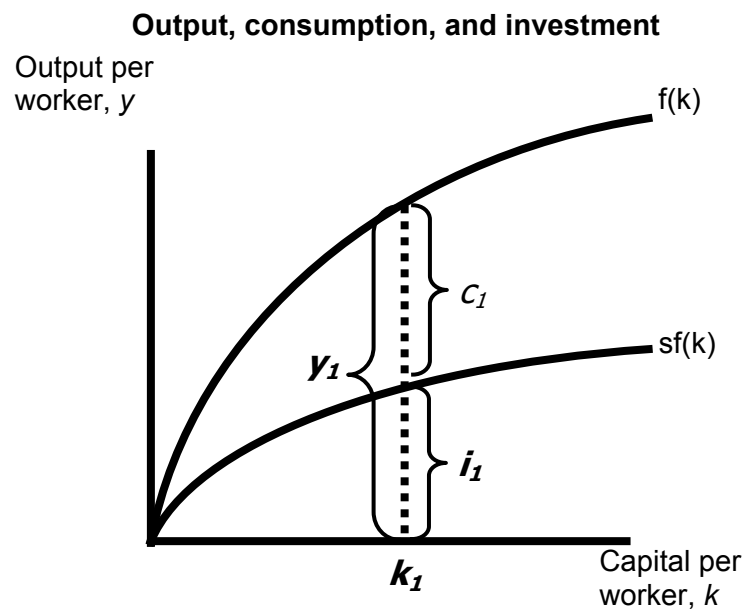

Depreciation

Depreciation per worker, δk

δ = the rate of depreciation
= the fraction of the capital stock that wears out each period

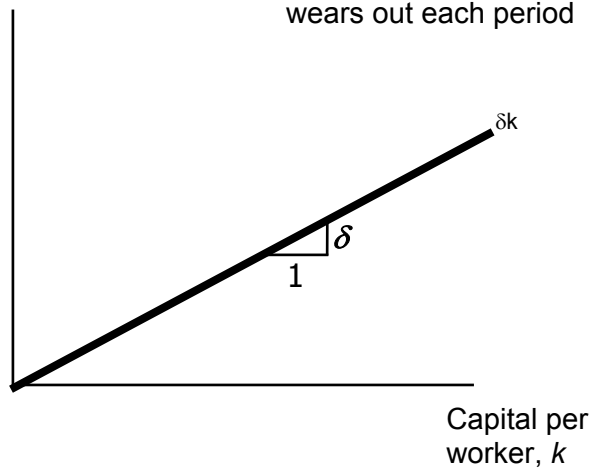

Capital accumulation

The basic idea:

Investment makes the capital stock bigger, depreciation makes it smaller.

Change in capital stock = investment – depreciation

$$\Delta k = i - \delta k$$

Since $i = s f(k)$, this becomes:

$$\Delta k = s f(k) - \delta k$$

The equation of motion for k

$$\Delta k = s f(k) - \delta k$$

- the Solow model's central equation
- Determines behavior of capital over time which, in turn, determines behavior of all of the other endogenous variables because they all depend on k . e.g., income per person: $y = f(k)$
Consumption per person: $c = (1-s) f(k)$

The steady state

If investment is just enough to cover depreciation

$$[s f(k) = \delta k],$$

then capital per worker will remain constant:

$$\Delta k = 0.$$

This constant value, denoted k^* , is called the steady state capital stock.

Investment and
depreciation

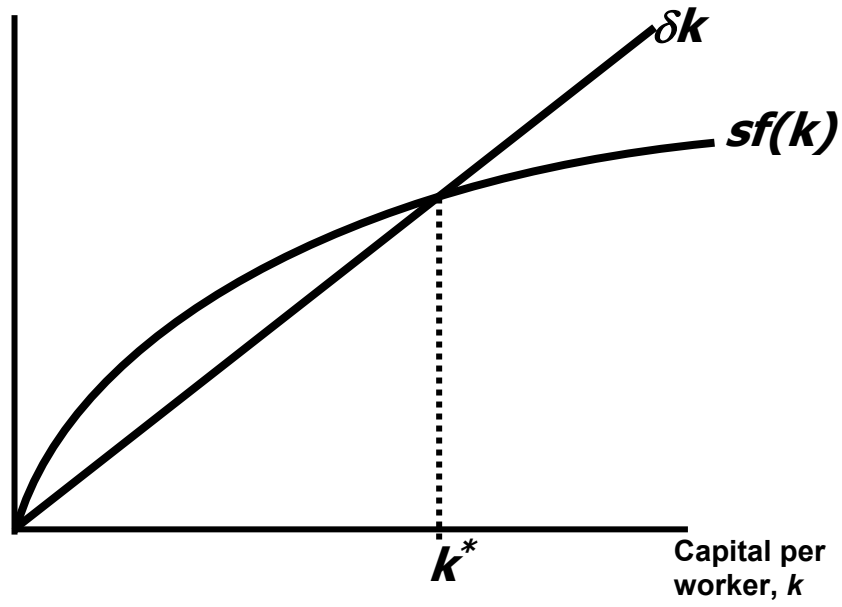

ECONOMIC GROWTH (Continued...)

Moving toward the steady state

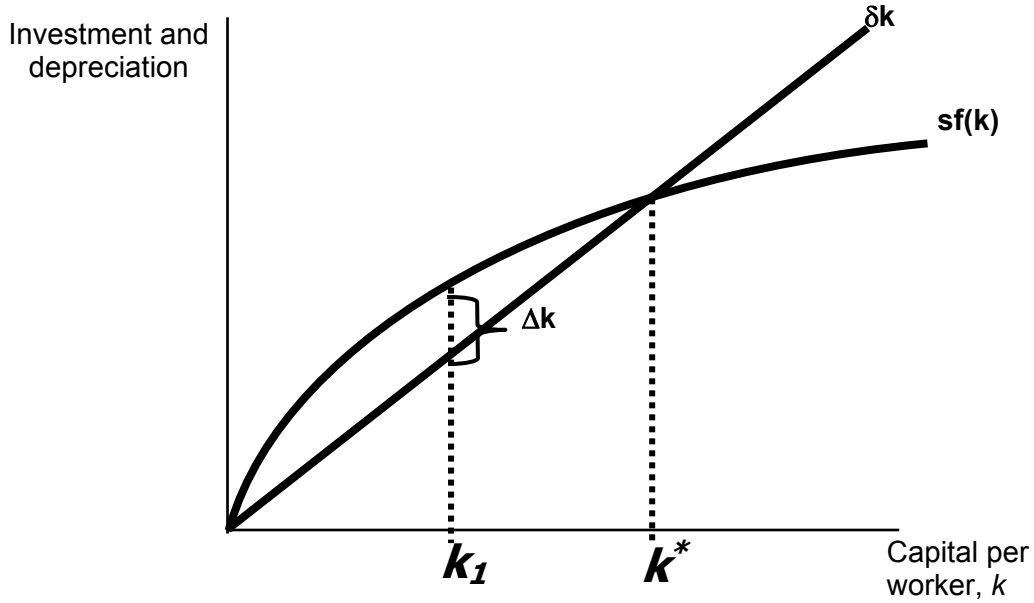
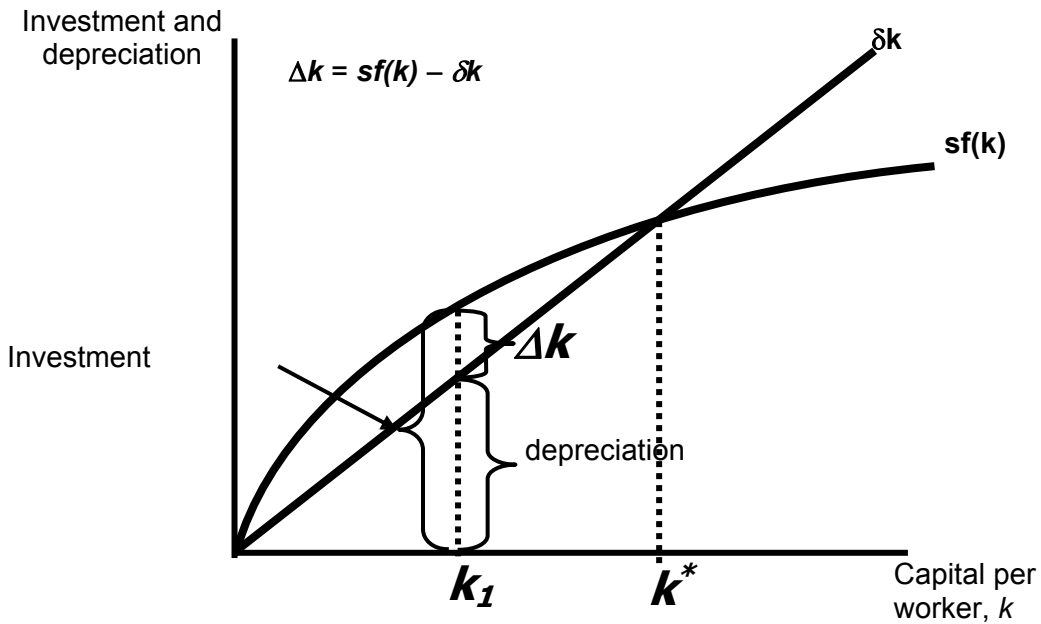

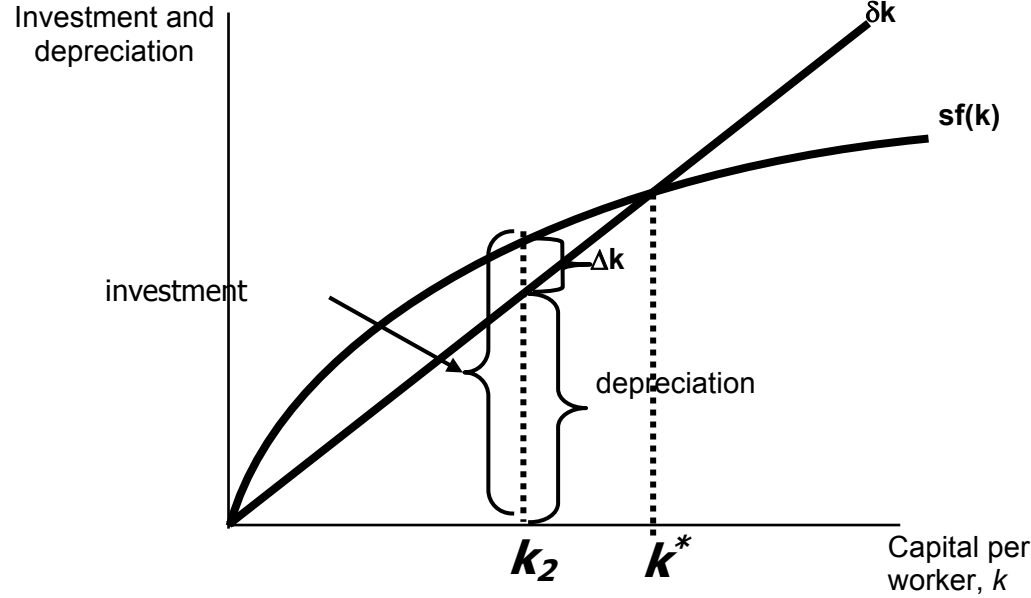
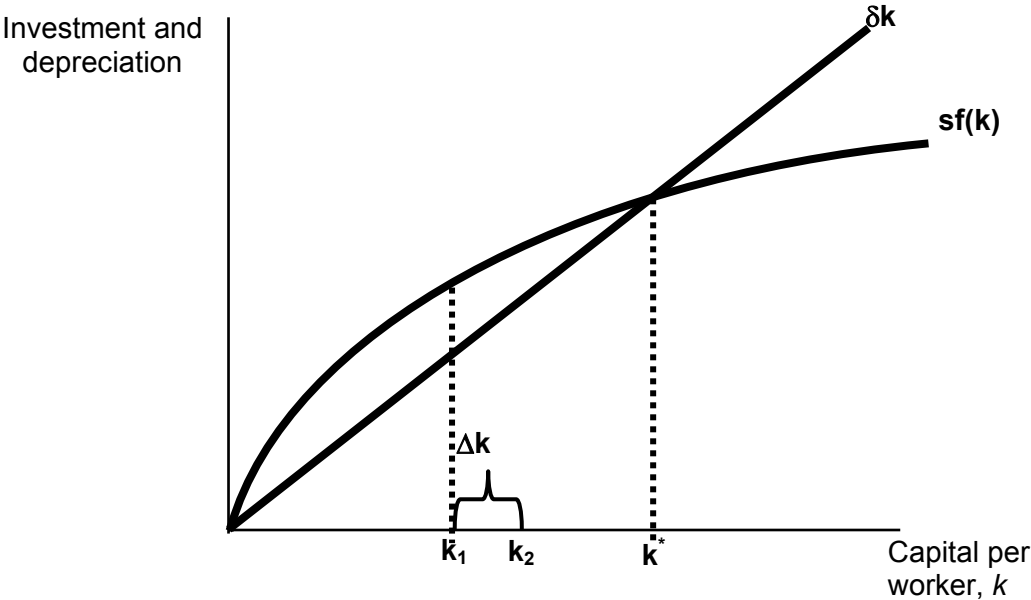

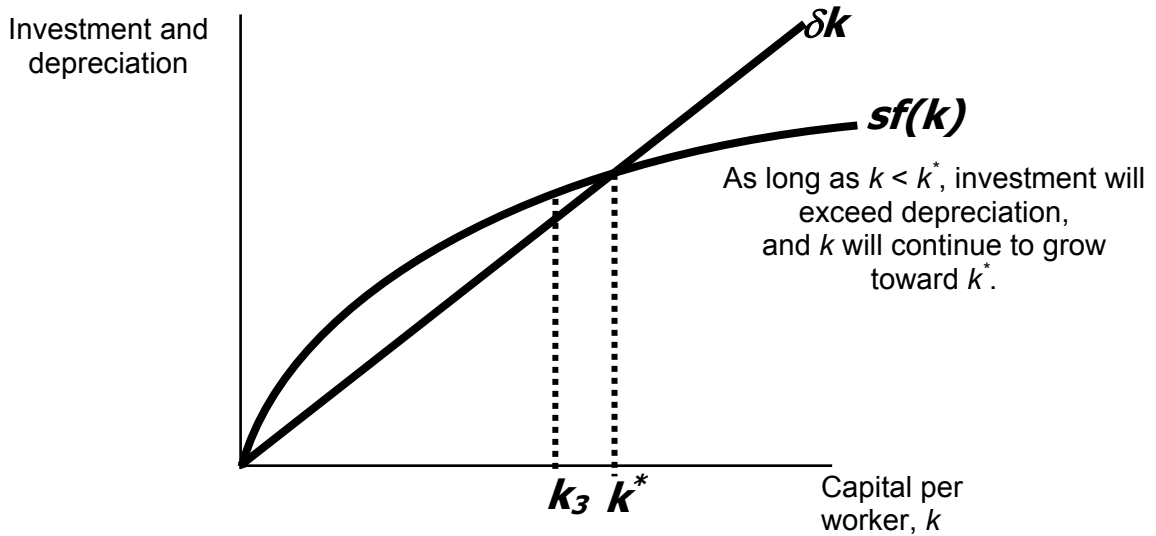
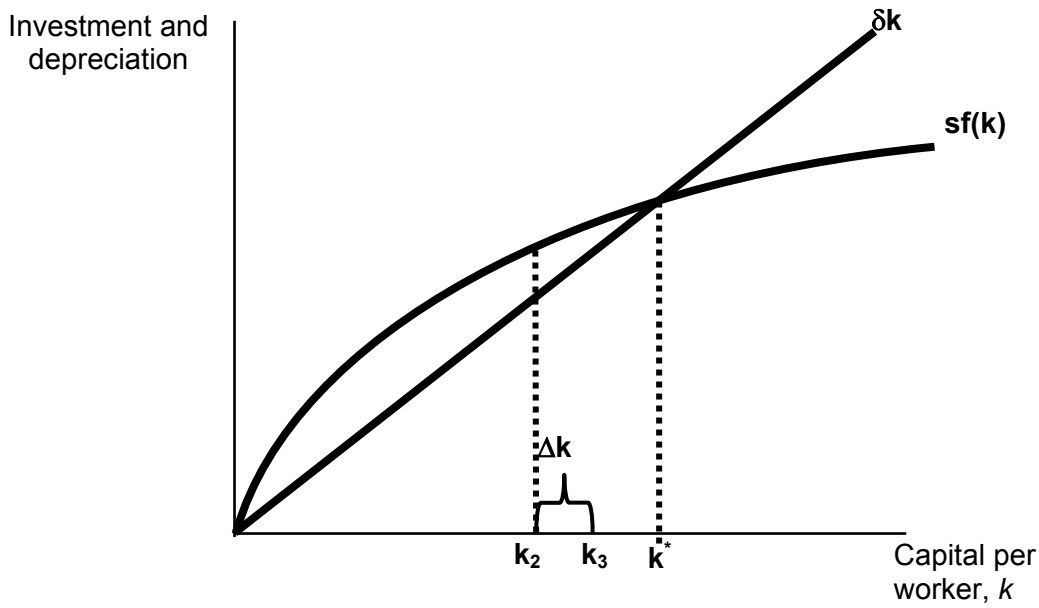

Now you try:

- Draw the Solow model diagram, labeling the steady state k^* .
- On the horizontal axis, pick a value greater than k^* for the economy's initial capital stock. Label it k_1 .
- Show what happens to k over time.
- Does k move toward the steady state or away from it?

The Steady State

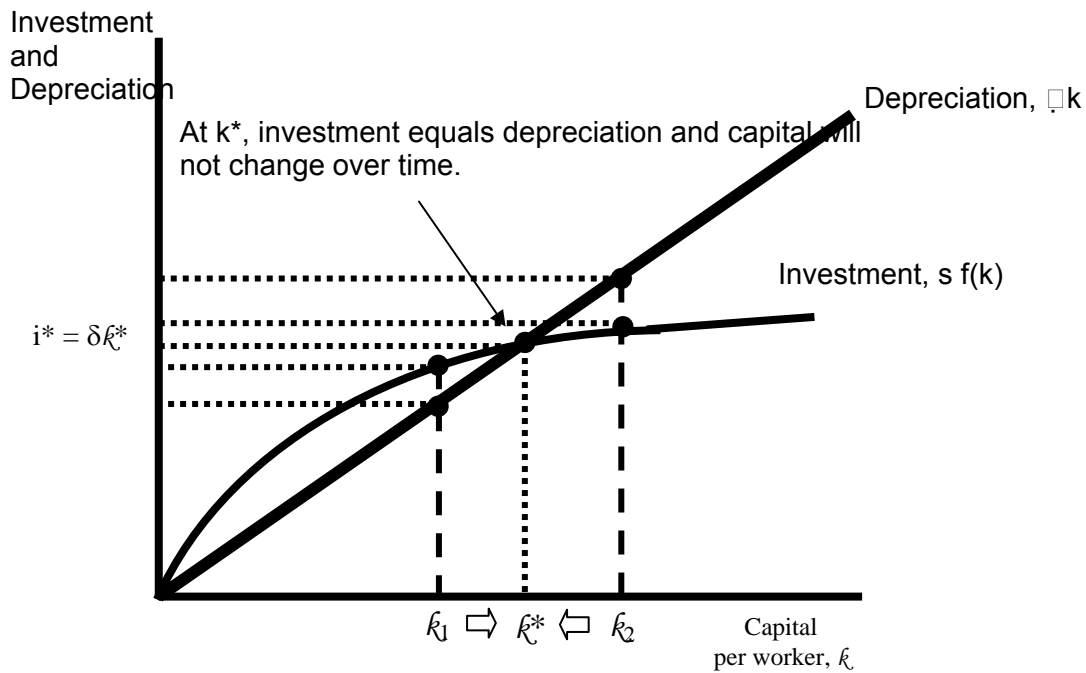

A numerical example

Production function (aggregate):

$$Y = F(K, L) = \sqrt{K \times L} = K^{1/2} L^{1/2}$$

To derive the per-worker production function, divide through by L :

$$\frac{Y}{L} = \frac{K^{1/2} L^{1/2}}{L} = \left(\frac{K}{L}\right)^{1/2}$$

Then substitute $y = Y/L$ and $k = K/L$ to get

$$y = f(k) = k^{1/2}$$

Assume:

- $s = 0.3$
- $\delta = 0.1$
- initial value of $k = 4.0$

Approaching the Steady State

Year	k	y	c	i	δk	Δk
1	4.000	2.000	1.400	0.600	0.400	0.200
2	4.200	2.049	1.435	0.615	0.420	0.195
3	4.395	2.096	1.467	0.629	0.440	0.189
4	4.584	2.141	1.499	0.642	0.458	0.184
...						
10	5.602	2.367	1.657	0.710	0.560	0.150
...						
25	7.351	2.706	1.894	0.812	0.732	0.080
...						
100	8.962	2.994	2.096	0.898	0.896	0.002
...						
∞	9.000	3.000	2.100	0.900	0.900	0.000

Exercise: solve for the steady state

Continue to assume

$$s = 0.3, \quad \delta = 0.1, \quad \text{and } y = k^{1/2}$$

Use the equation of motion

$$\Delta k = s f(k) - \delta k$$

to solve for the steady-state values of k , y , and c .

Solution:

$$\Delta k = 0 \quad \text{def. of steady state}$$

$$s f(k^*) = \delta k^* \quad \text{eq'n of motion with } \Delta k = 0$$

$$0.3\sqrt{k^*} = 0.1k^* \quad \text{using assumed values}$$

$$3 = \frac{k^*}{\sqrt{k^*}} = \sqrt{k^*}$$

$$\text{Solve to get: } k^* = 9 \quad \text{and } y^* = \sqrt{k^*} = 3$$

$$\text{Finally, } c^* = (1 - s)y^* = 0.7 \times 3 = 2.1$$

An increase in the saving rate

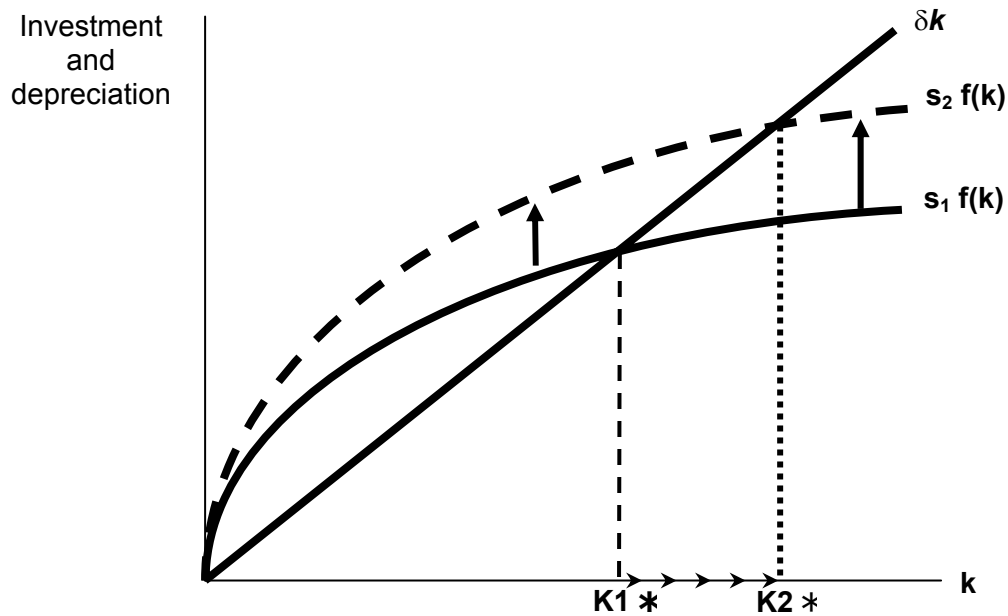

An increase in the saving rate raises investment causing the capital stock to grow toward a new steady state

Prediction:

- Higher $s \Rightarrow$ higher k^* .
- And since $y = f(k)$,
higher $k^* \Rightarrow$ higher y^* .
- Thus, the Solow model predicts that countries with higher rates of saving and investment will have higher levels of capital and income per worker in the long run.

International Evidence on Investment Rates and Income per Person

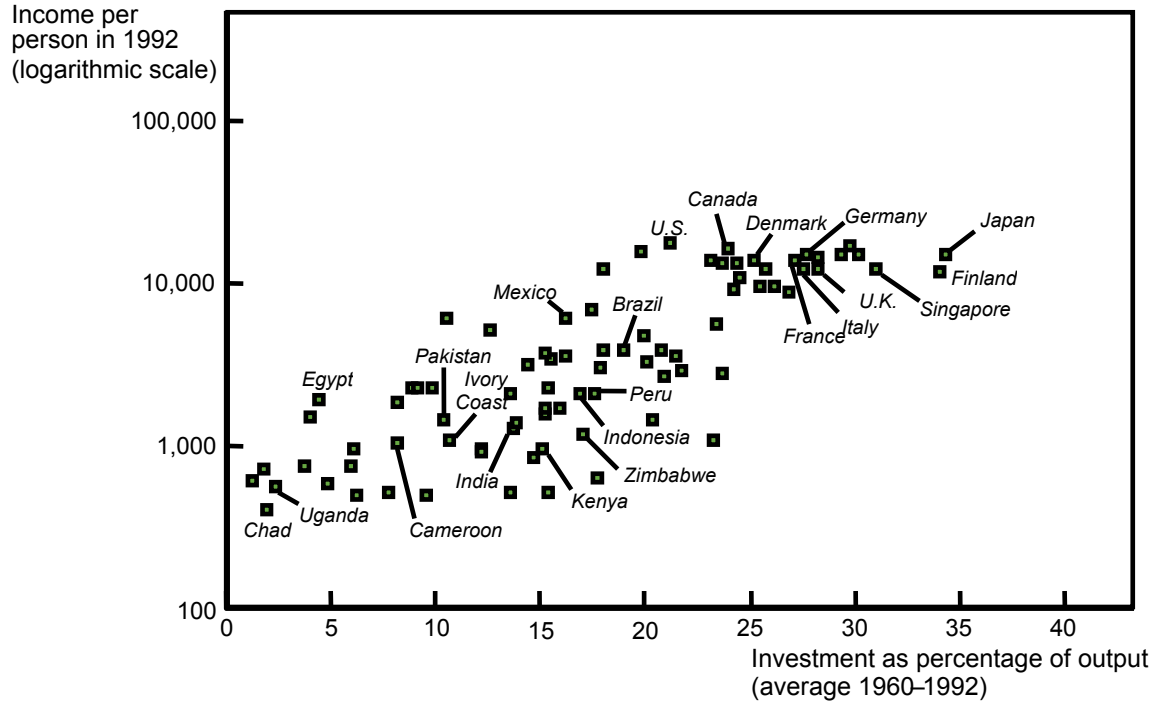

ECONOMIC GROWTH (Continued...)

The Golden Rule: introduction

- Different values of s lead to different steady states. How do we know which is the “best” steady state?
- Economic well-being depends on consumption, so the “best” steady state has the highest possible value of consumption per person:

$$c^* = (1-s) f(k^*)$$

- An increase in s
 - leads to higher k^* and y^* , which may raise c^*
 - reduces consumption's share of income $(1-s)$, which may lower c^*
- So, how do we find the s and k^* that maximize c^* ?

The Golden Rule Capital Stock

K^*_{gold} = the Golden Rule level of capital, the steady state value of k that maximizes consumption.

To find it, first express c^* in terms of k^* :

$$\begin{aligned} C^* &= y^* - i^* \\ &= f(k^*) - i^* \\ &= f(k^*) - \delta k^* \end{aligned}$$

In general:

$$i = \Delta k + \delta k$$

In the steady state: $i^* = \delta k^*$ because $\Delta k = 0$.

Then, graph $f(k^*)$ and δk^* , and look for the point where the gap between them is biggest.

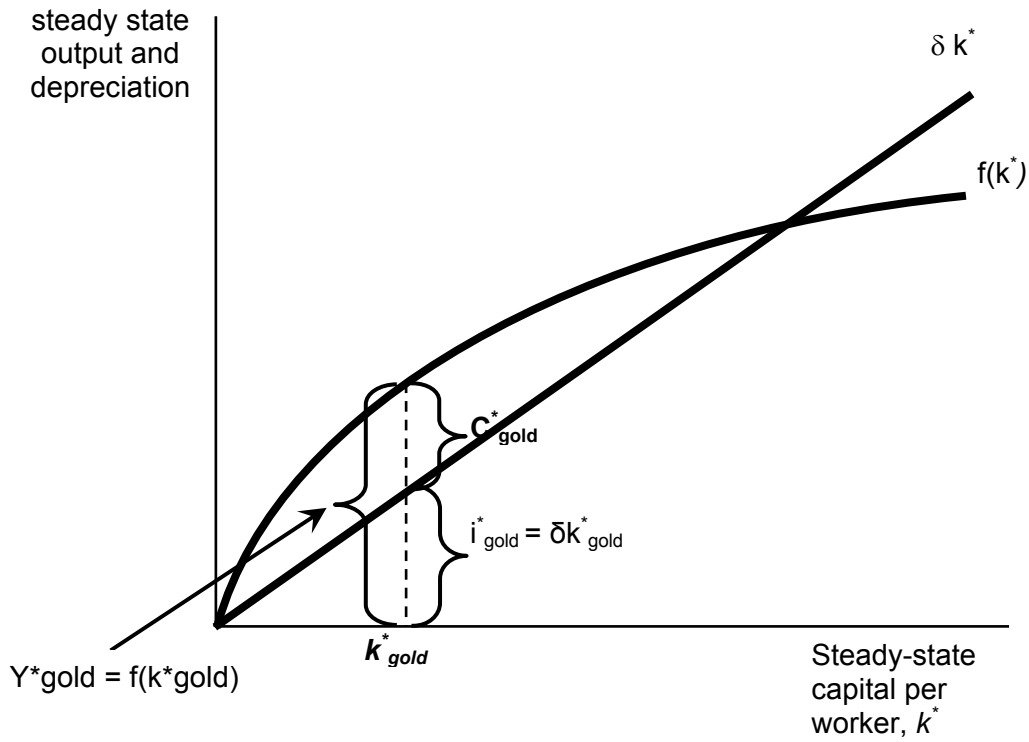

$c^* = f(k^*) - \delta k^*$ is biggest where the slope of the production function equals the slope of the depreciation line: $MPK = \delta$

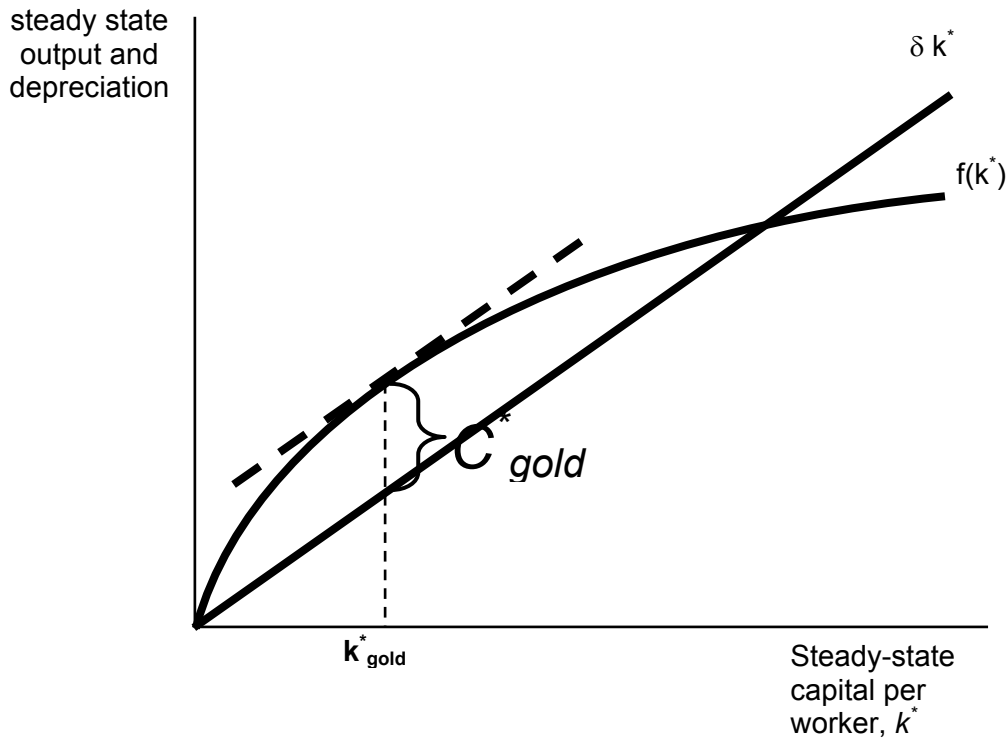

The transition to the Golden Rule Steady State

- The economy does NOT have a tendency to move toward the Golden Rule steady state.
- Achieving the Golden Rule requires that Policymakers adjust s .
- This adjustment leads to a new steady state with higher consumption.
- But what happens to consumption during the transition to the Golden Rule?

Starting with too much capital

If $k^* > k_{gold}^*$

then increasing c^* requires a fall in s .

In the transition to the Golden Rule, consumption is higher at all points in time.

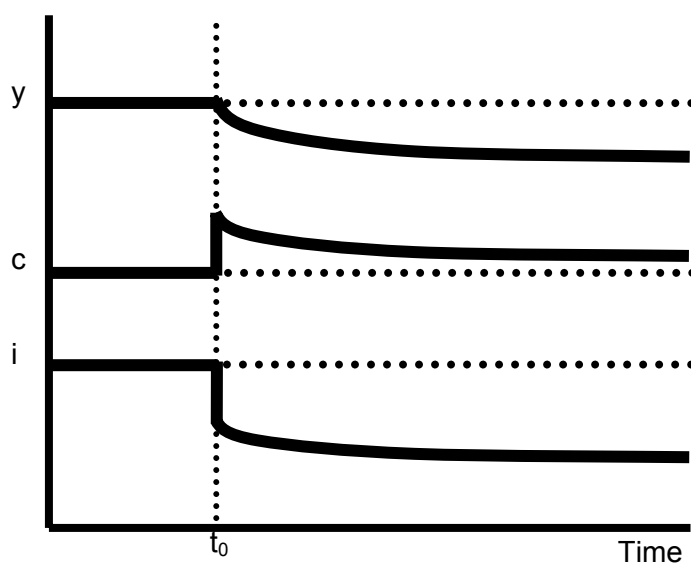

Starting with too little capital

If $k^* < k_{gold}^*$

then increasing c^* requires an increase in s .

Future generations enjoy higher consumption, but the current one experiences an initial drop in consumption.

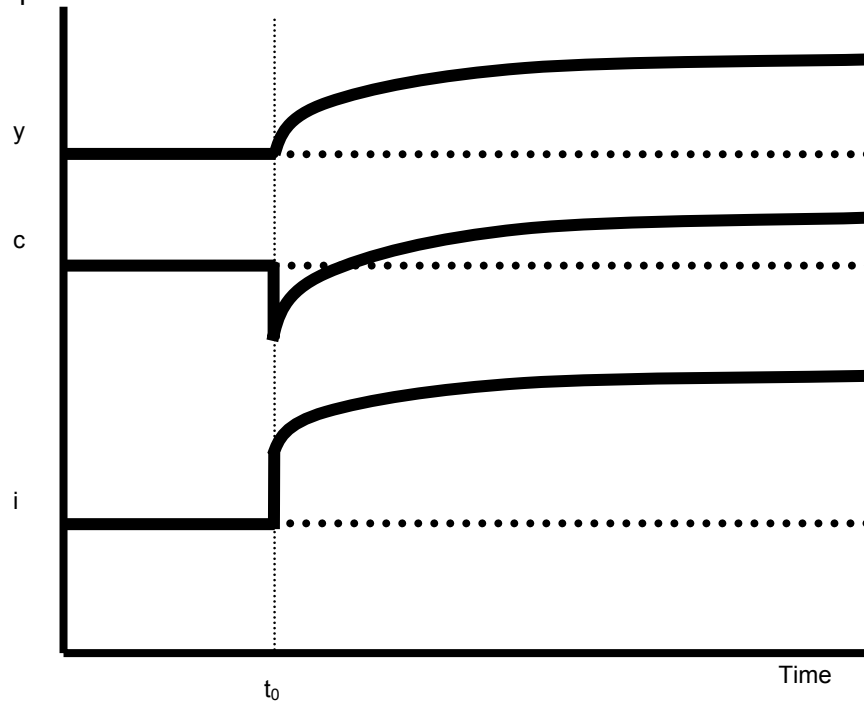

- The basic Solow model cannot explain sustained economic growth. It simply says that high rates of saving lead to high growth temporarily, but the economy eventually approaches a steady state.
- We need to incorporate two sources of growth to explain sustained economic growth: population and technological progress.

Population Growth

- Assume that the population--and labor force-- grow at rate n . (n is exogenous)

$$\frac{\Delta L}{L} = n$$

- EX: Suppose $L = 1000$ in year 1 and the population is growing at 2%/year ($n = 0.02$). Then $\Delta L = n L = 0.02 \times 1000 = 20$, so $L = 1020$ in year 2.

Break-even investment

$(\delta + n)k$ = break-even investment, the amount of investment necessary to keep k constant.

Break-even investment includes:

- δk to replace capital as it wears out
- $n k$ to equip new workers with capital (otherwise, k would fall as the existing capital stock would be spread more thinly over a larger population of workers)

The equation of motion for k

- With population growth, the equation of motion for k is

$$\Delta k = s f(k) - (\delta + n) k$$

Where

$S f(k)$ = actual investment

$(\delta + n) k$ = breakeven investment

The impact of population growth

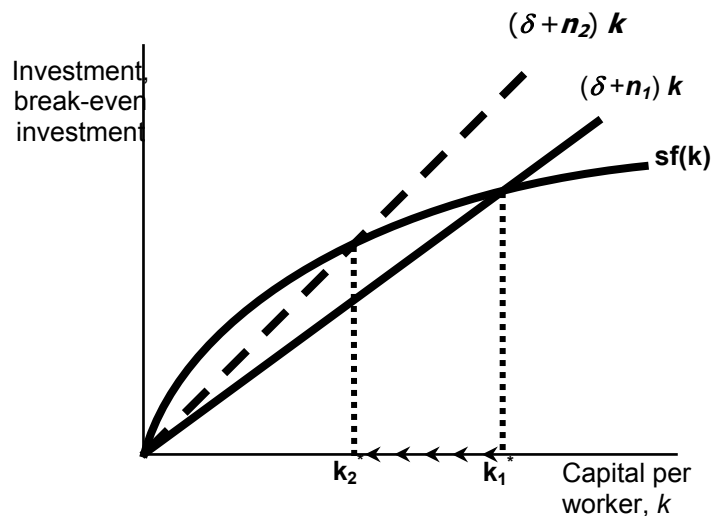

Prediction:

- Higher $n \Rightarrow$ lower k^* .
- And since $y = f(k)$,
lower $k^* \Rightarrow$ lower y^* .
- Thus, the Solow model predicts that countries with higher population growth rates will have lower levels of capital and income per worker in the long run.

The Golden Rule with Population Growth

To find the Golden Rule capital stock, we again express c^* in terms of k^* :

$$\begin{aligned} c^* &= y^* - i^* \\ &= f(k^*) - (\delta + n)k^* \end{aligned}$$

c^* is maximized when

$$MPK = \delta + n$$

or equivalently,

$$MPK - \delta = n$$

In the Golden Rule Steady State, the marginal product of capital net of depreciation equals the population growth rate.

ECONOMIC GROWTH (Continued...)

Issues under Consideration

- Technological progress in the Solow model
- Policies to promote growth
- Growth empirics:
Confronting the theory with facts
- Endogenous growth:
Two simple models in which the rate of technological progress is endogenous

Introduction

Previously, in the Solow model

- The production technology was held constant
- Income per capita was constant in the steady state.

Neither point is true in the real world

Tech. progress in the Solow model

- A new variable: E = labor efficiency
- Assume:
Technological progress is labor-augmenting: it increases labor efficiency at the exogenous rate g :

$$g = \frac{\Delta E}{E}$$

- We now write the production function as:

$$Y = F(K, L \times E)$$

- Where $L \times E$ = the number of effective workers.
 - Hence, increases in labor efficiency have the same effect on output as increases in the labor force.

- Notation:

$y = Y/LE$ = output per effective worker

$k = K/LE$ = capital per effective worker

- Production function per effective worker:
 $y = f(k)$
- Saving and investment per effective worker:
 $s y = s f(k)$

$(\delta + n + g)k$ = break-even investment:
the amount of investment necessary to keep k constant.

Consists of:

δk to replace depreciating capital

$n k$ to provide capital for new workers

$g k$ to provide capital for the new “effective” workers created by technological progress

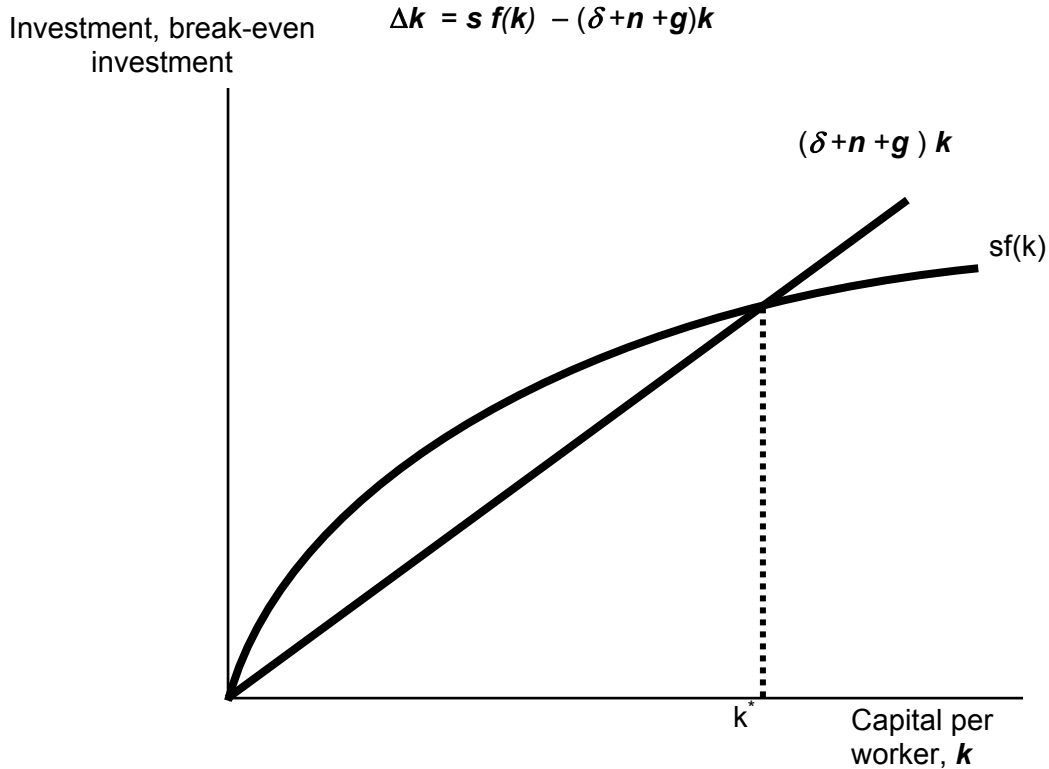

Steady-State Growth Rates in the Solow Model with Tech. Progress

Variable	Symbol	Steady-State growth rate
Capital per effective worker	$k = K / (L \times E)$	0
Output per effective worker	$y = Y / (L \times E)$	0
Output per worker	$(Y / L) = y \times E$	g
Total output	$Y = y \times E \times L$	$n + g$

The Golden Rule

To find the Golden Rule capital stock, express c^* in terms of k^* :

$$c^* = y^* - i^* = f(k^*) - (\delta + n + g) k^*$$

c^* is maximized when

$$MPK = \delta + n + g$$

or equivalently,

$$MPK - \delta = n + g$$

In the Golden Rule Steady State, the marginal product of capital net of depreciation equals the population growth rate plus the rate of tech progress.

The Golden Rule Capital Stock

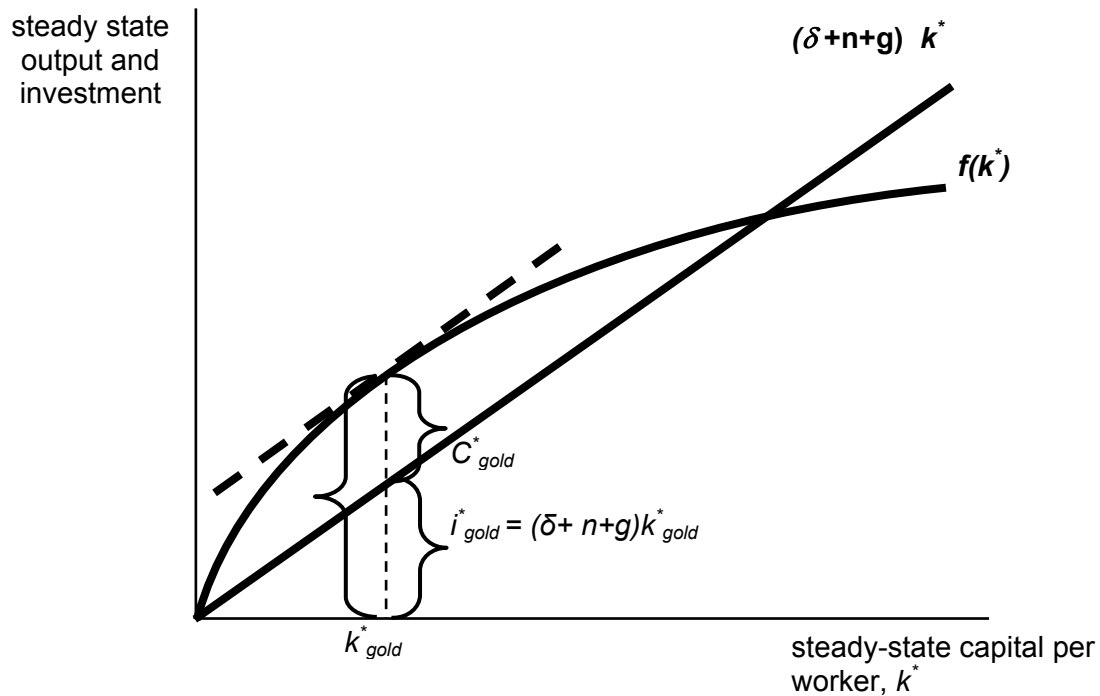

Policies to promote growth

Four policy questions:

- Are we saving enough? Too much?
- What policies might change the saving rate?
- How should we allocate our investment between privately owned physical capital, public infrastructure, and “human capital”?
- What policies might encourage faster technological progress?

1. Evaluating the Rate of Saving

- Use the Golden Rule to determine whether our saving rate and capital stock are too high, too low, or about right.
- To do this, we need to compare $(MPK - \delta)$ to $(n + g)$.
- If $(MPK - \delta) > (n + g)$, then we are below the Golden Rule steady state and should increase s .
- If $(MPK - \delta) < (n + g)$, then we are above the Golden Rule steady state and should reduce s .

To estimate $(MPK - \delta)$, we use three facts about an economy;

1. $k = 2.5 y$
the capital stock is about 2.5 times one year's GDP.
2. $\delta k = 0.1 y$
about 10% of GDP is used to replace depreciating capital.
3. $MPK \times k = 0.3 y$
Capital income is about 30% of GDP

So

1. $k = 2.5 y$
2. $\delta k = 0.1 y$
3. $MPK \times k = 0.3 y$

To determine δ , divided 2 by 1:

$$\frac{\delta k}{k} = \frac{0.1 y}{2.5 y} \Rightarrow \delta = \frac{0.1}{2.5} = 0.04$$

To determine MPK, divided 3 by 1:

$$\frac{MPK \times k}{k} = \frac{0.3 y}{2.5 y} \Rightarrow MPK = \frac{0.3}{2.5} = 0.12$$

Hence, $MPK - \delta = 0.12 - 0.04 = 0.08$

- Real GDP grows an average of 3%/year,
so $n + g = 0.03$
- Thus, in this economy,
 $MPK - \delta = 0.08 > 0.03 = n + g$

Conclusion:

The economy is below the Golden Rule steady state:

if we increase saving rate of this economy, the economy will have faster growth until it reaches to a new steady state with higher consumption per capita.

LESSON 23

ECONOMIC GROWTH (Continued...)**2. Policies to increase the saving rate**

- Reduce the government budget deficit (or increase the budget surplus)
- Increase incentives for private saving:
 - Reduce capital gains tax, corporate income tax, estate tax as they discourage saving
 - Replace federal income tax with a consumption tax
 - Expand tax incentives for individual retirement accounts and other retirement savings accounts

3. Allocating the economy's investment

- In the Solow model, there's one type of capital.
- In the real world, there are many types, which we can divide into three categories:
 - Private capital stock
 - Public infrastructure
 - Human capital: the knowledge and skills that workers acquire through education
- How should we allocate investment among these types?

Two viewpoints

1. Equalize tax treatment of all types of capital in all industries, and then let the market allocate investment to the type with the highest marginal product.
2. **Industrial policy:** Govt. should actively encourage investment in capital of certain types or in certain industries, because they may have positive externalities (by-products) that private investors don't consider.

Possible problems with industrial policy

- Does the govt. have the ability to "pick winners" (choose industries with the highest return to capital or biggest externalities)?
- Would politics rather than economics influence which industries get preferential treatment?

4. Encouraging technological progress

- Patent laws: encourage innovation by granting temporary monopolies to inventors of new products
- Tax incentives for R&D
- Grants to fund basic research at universities
- Industrial policy: encourage specific industries that are key for rapid tech. progress (subject to the concerns on the preceding slide)

Growth empirics: Confronting the Solow model with the facts

Solow model's steady state exhibits balanced growth - many variables grow at the same rate.

- Solow model predicts Y/L and K/L grow at same rate (g), so that K/Y should be constant. This is true in the real world.
- Solow model predicts real wage grows at same rate as Y/L , while real rental price is constant. Also true in the real world.

Convergence

- Solow model predicts that, other things equal, "poor" countries (with lower Y/L and K/L) should grow faster than "rich" ones.
- If true, then the income gap between rich & poor countries would shrink over time, and living standards "converge."
- In real world, many poor countries do NOT grow faster than rich ones. Does this mean the Solow model fails?
- No, because "other things" aren't equal.
 - In samples of countries with similar savings & population growth rates, income gaps shrink about 2%/year.
 - In larger samples, if one controls for differences in saving, population growth, and human capital, incomes converge by about 2%/year.
- What the Solow model really predicts is conditional convergence - countries converge to their own steady states, which are determined by saving, population growth, and education. And this prediction comes true in the real world.

Factor accumulation vs. Production efficiency

Two reasons why income per capita are lower in some countries than others:

1. Differences in capital (physical or human) per worker
2. Differences in the efficiency of production (the height of the production function)

Studies:

- Both factors are important
- Countries with higher capital (phys or human) per worker also tend to have higher production efficiency

Explanations:

- Production efficiency encourages capital accumulation
- Capital accumulation has externalities that raise efficiency
- A third, unknown variable causes cap accumulation and efficiency to be higher in some countries than others

Endogenous Growth Theory

- Solow model:
 - Sustained growth in living standards is due to tech progress
 - The rate of tech progress is exogenous

- Endogenous growth theory:
 - a set of models in which the growth rate of productivity and living standards is endogenous

A basic model

- Production function: $Y = A K$
where A is the amount of output for each unit of capital (A is exogenous & constant)
- Key difference between this model & Solow: MPK is constant here, diminishes in Solow
- Investment: $s Y$
- Depreciation: δK
- Equation of motion for total capital:

$$\Delta K = s Y - \delta K$$

- Divide through by K and use $Y = A K$, get:

$$\frac{\Delta Y}{Y} = \frac{\Delta K}{K} = sA - \delta$$

- If $sA > \delta$, then income will grow forever, and investment is the “engine of growth.”
- Here, the permanent growth rate depends on s . In Solow model, it does not.

Does capital have diminishing returns or not?

- Yes, if “capital” is narrowly defined (plant & equipment).
- Perhaps not, with a broad definition of “capital” (physical & human capital, knowledge).
- Some economists believe that knowledge exhibits increasing returns.
- In the endogenous growth model, the assumption of constant returns to capital is more plausible.

A two-sector model

- Two sectors:
 - Manufacturing firms produce goods
 - Research universities produce knowledge that increases labor efficiency in manufacturing
- u = fraction of labor in research (u is exogenous)
- Manufacturing production function: $Y = F [K, (1-u) E L]$
- Research production function: $\Delta E = g(u) E$
- Cap accumulation: $\Delta K = s Y - \delta K$
- In the steady state, manufacturing output per worker and the standard of living grow at rate $\Delta E/E = g(u)$.
- Key variables:

- s : affects the level of income, but not its growth rate (same as in Solow model)
- u : affects level and growth rate of income

- Question:
Would an increase in u be unambiguously good for the economy?

Three facts about R&D in the real world

1. Much research is done by firms seeking profits
2. Firms profit from research because
 - New inventions can be patented, creating a stream of monopoly profits until the patent expires
 - There is an advantage to being the first firm on the market with a new product
3. Innovation produces externalities that reduce the cost of subsequent innovation.

Much of the new endogenous growth theory attempts to incorporate these facts into models to better understand tech progress.

Is the private sector doing enough R&D?

- The existence of positive externalities in the creation of knowledge suggests that the private sector is not doing enough R&D.
- But, there is much duplication of R&D effort among competing firms.
- Estimates: The social return to R&D is at least 40% per year.
Thus, many believe govt should encourage R&D.

LESSON 24

AGGREGATE DEMAND AND AGGREGATE SUPPLY**Issues under Consideration**

- Difference between short run & long run
- Introduction to aggregate demand
- Aggregate supply in the short run & long run
- See how model of aggregate supply and demand can be used to analyze short-run and long-run effects of “shocks”

Time horizons

- Long run: Prices are flexible, respond to changes in supply or demand
 - Short run: many prices are “sticky” at some predetermined level
- The economy behaves much differently when prices are sticky.

In Classical Macroeconomic Theory,

Recall

- Output is determined by the supply side:
 - Supplies of capital, labor
 - Technology
- Changes in demand for goods & services (C, I, G) only affect prices, not quantities.
- Complete price flexibility is a crucial assumption, so classical theory applies in the long run.

When prices are sticky

...output and employment also depend on demand for goods & services, which is affected by

- Fiscal policy (G and T)
- Monetary policy (M)
- Other factors, like exogenous changes in C or I .
- How? Why?

The model of aggregate demand and supply

- The paradigm that most mainstream economists & policymakers use to think about economic fluctuations and policies to stabilize the economy
- Shows how the price level and aggregate output are determined
- Shows how the economy’s behavior is different in the short run and long run

Aggregate demand

- The aggregate demand curve shows the relationship between the price level and the quantity of output demanded.
- For an intro to the AD/AS model, we use a simple theory of aggregate demand based on the Quantity Theory of Money.

- In the coming lectures, we shall discuss the theory of aggregate demand in more detail.

The Quantity Equation as Aggregate Demand

- Recall the quantity equation

$$M V = P Y$$

And the money demand function it implies:

$$(M/P)^d = k Y$$

where $V = 1/k =$ velocity.

- For given values of M and V , these equations imply an inverse relationship between P and Y :

The downward-sloping AD curve

An increase in the price level causes a fall in real money balances (M/P) , causing a decrease in the demand for goods & services.

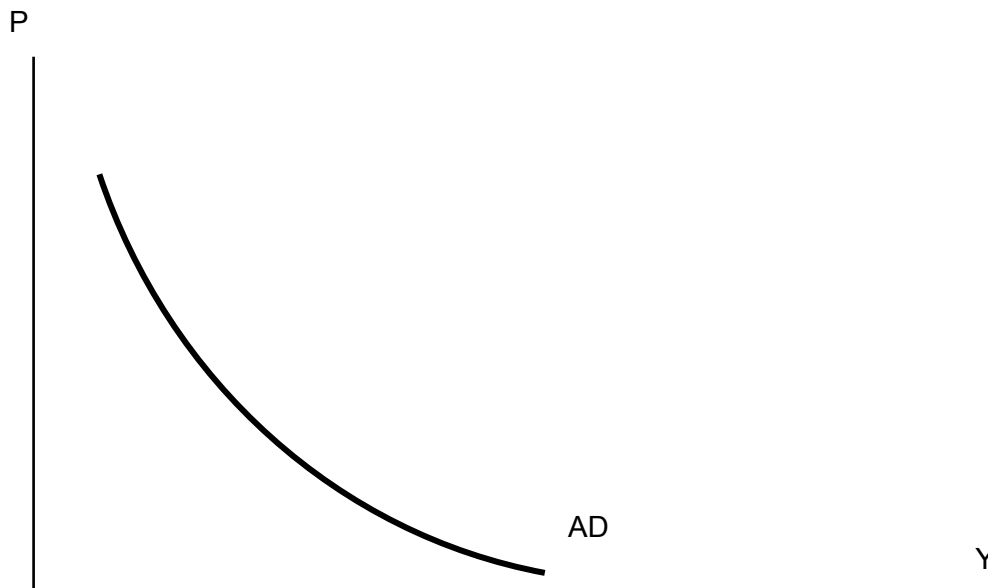

Shifting the AD curve

An increase in the money supply shifts the AD curve to the right.

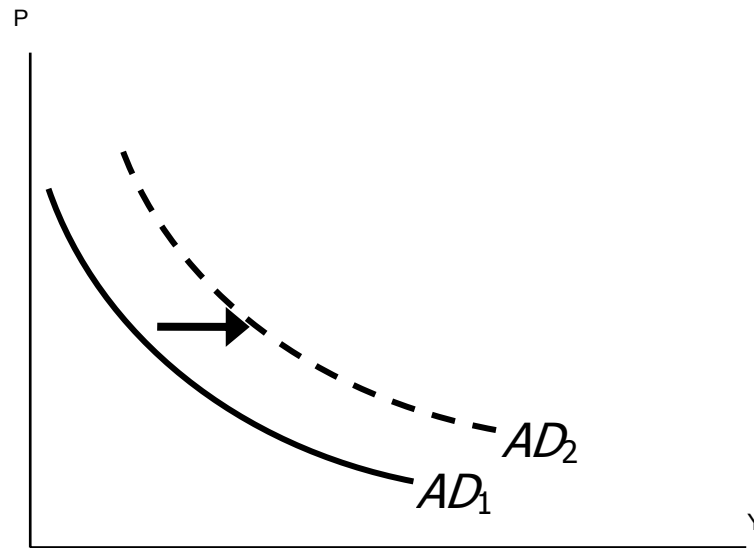

Aggregate Supply in the Long Run

- Recall

In the long run, output is determined by factor supplies and technology

$$\bar{Y} = F(\bar{K}, \bar{L})$$

\bar{Y} is the **full-employment** or **natural** level of output, the level of output at which the economy's resources are fully employed.

"Full employment" means that unemployment equals its natural rate.

- Full-employment output does not depend on the price level, so the long run aggregate supply (LRAS) curve is vertical:

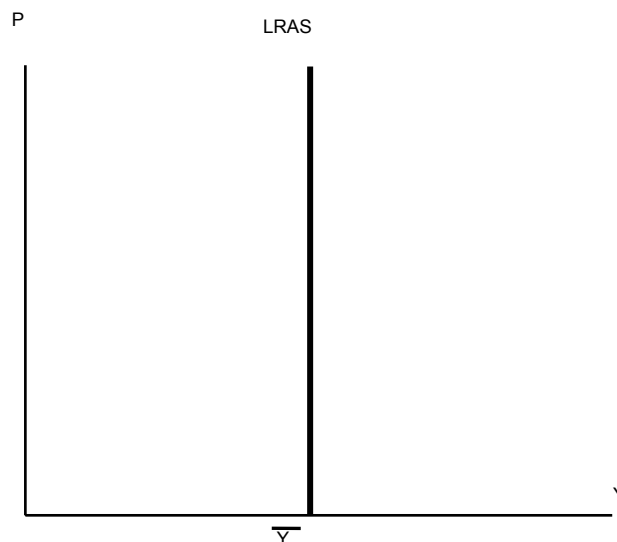

Long-run effects of an increase in M

An increase in M shifts the AD curve to the right.

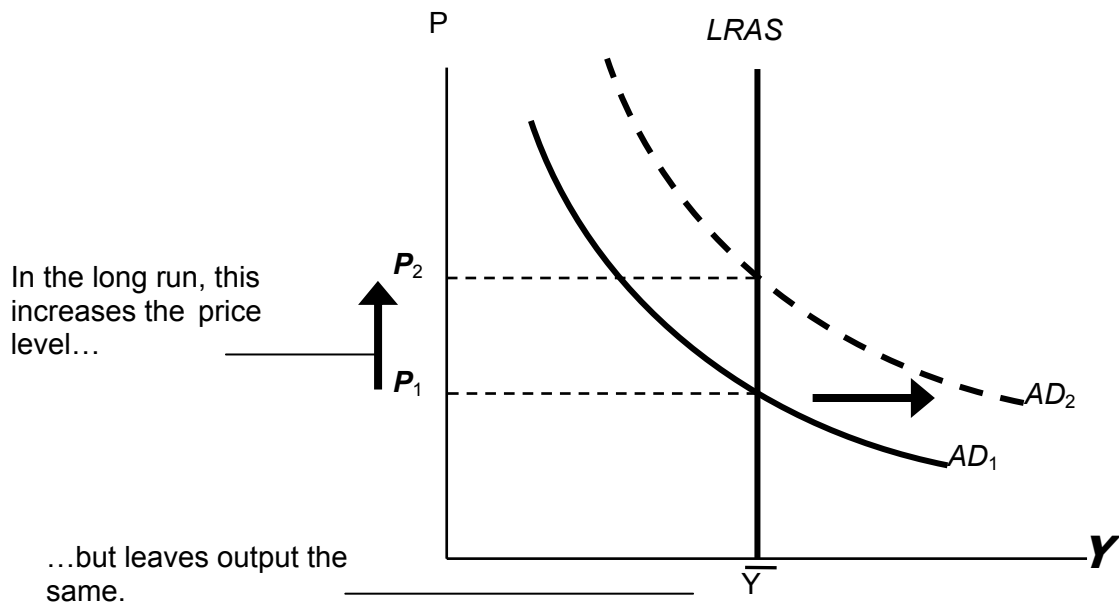

Aggregate Supply in the Short Run

- In the real world, many prices are sticky in the short run.
- For now we assume that all prices are stuck at a predetermined level in the short run...
- ...and that firms are willing to sell as much as their customers are willing to buy at that price level.
- Therefore, the short-run aggregate supply (SRAS) curve is horizontal

The SRAS curve is horizontal: The price level is fixed at a predetermined level, and firms sell as much as buyers demand.

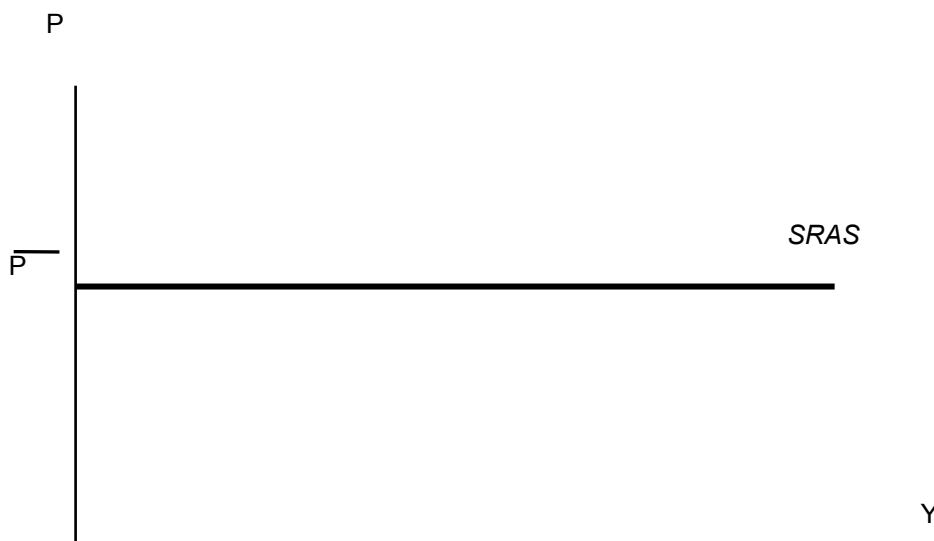

Short-run effects of an increase in M

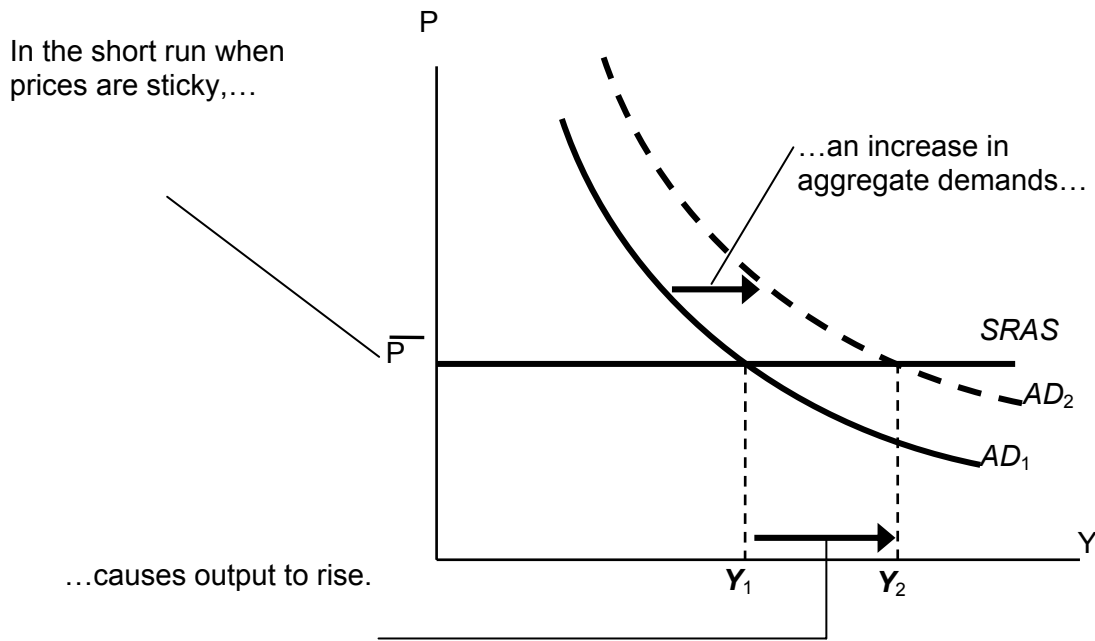

From the short run to the long run

Over time, prices gradually become “unstuck.” When they do, will they rise or fall?

In the short-run equilibrium, if	then over time, the price level will
$Y > \bar{Y}$	Rise
$Y < \bar{Y}$	Fall
$Y = \bar{Y}$	remain constant

This adjustment of prices is what moves the economy to its long-run equilibrium.

The SR & LR effects of $\Delta M > 0$

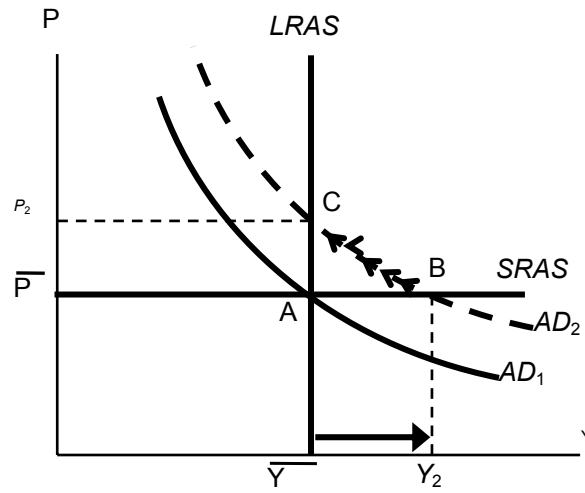

A = initial equilibrium

B = new short-run equilibrium after SBP increases M

C = long-run equilibrium

LESSON 25

AGGREGATE DEMAND AND AGGREGATE SUPPLY (Continued...)

How shocking!!!

Shocks: exogenous changes in aggregate supply or demand

Shocks temporarily push the economy away from full-employment.

A demand shock

- The economy begins in long-run equilibrium at point A. An increase in aggregate demand, due to an increase in the velocity of money, moves the economy from point A to point B, where output is above its natural level. As prices rise, output gradually returns to its natural rate, and the economy moves from point B to point C.

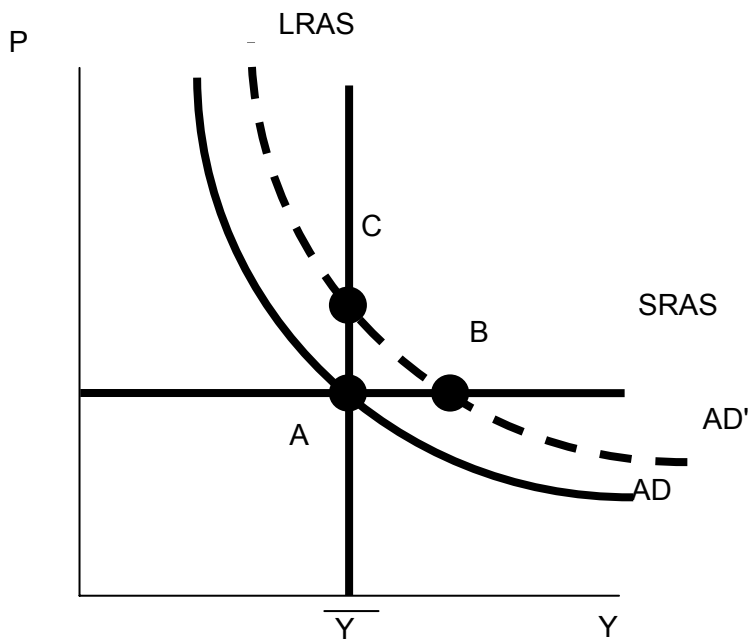

- Exogenous decrease in velocity
- If the money supply is held constant, then a decrease in V means people will be using their money in fewer transactions, causing a decrease in demand for goods and services:

The effects of a negative demand shock

The shock shifts AD left, causing output and employment to fall in the short run. Over time, prices fall and the economy moves down its demand curve toward full-employment.

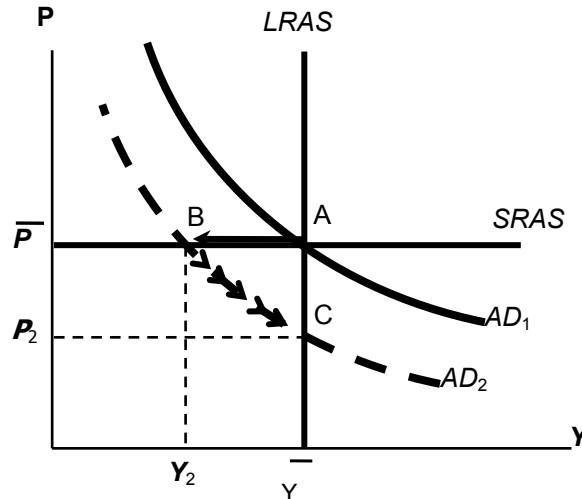

Supply shocks

A supply shock alters production costs, affects the prices that firms charge. (Also price shocks)

Examples of adverse supply shocks:

- Bad weather reduces crop yields, pushing up food prices.
- Workers unionize, negotiate wage increases.
- New environmental regulations require firms to reduce emissions. Firms charge higher prices to help cover the costs of compliance.

(Favorable supply shocks lower costs and prices)

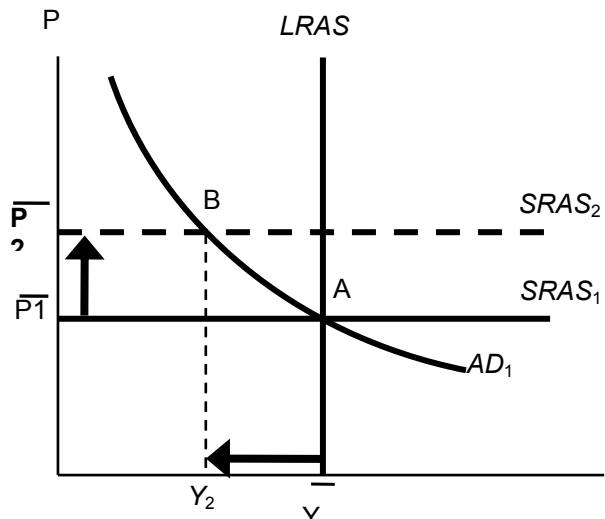

The adverse supply shock moves the economy to point B.

Stabilization policy

- def: policy actions aimed at reducing the severity of short-run economic fluctuations.
- Example: Using monetary policy to combat the effects of adverse supply shocks:
But central bank shock by raising accommodates the aggregate demand.

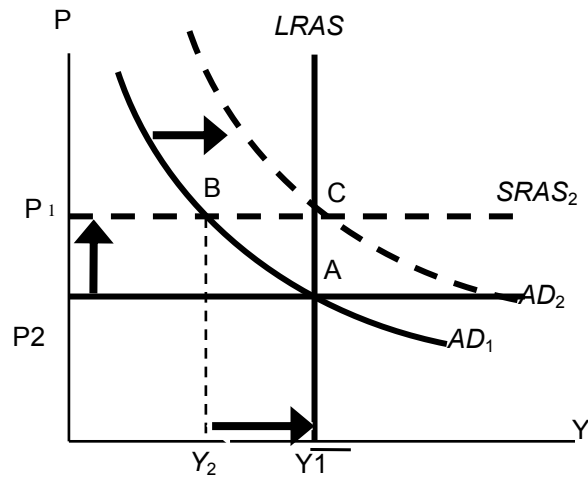

Results:

P is permanently higher, but **Y** remains at its full-employment level.

The 1970s oil shocks

- Early 1970s: OPEC coordinates a reduction in the supply of oil.
- Oil prices rose
 - 11% in 1973
 - 68% in 1974
 - 16% in 1975
- Such sharp oil price increases are supply shocks because they significantly impact production costs and prices.

The oil price shock shifts SRAS up, causing output and employment to fall. In absence of further price shocks, prices will fall over time and economy moves back toward full employment.

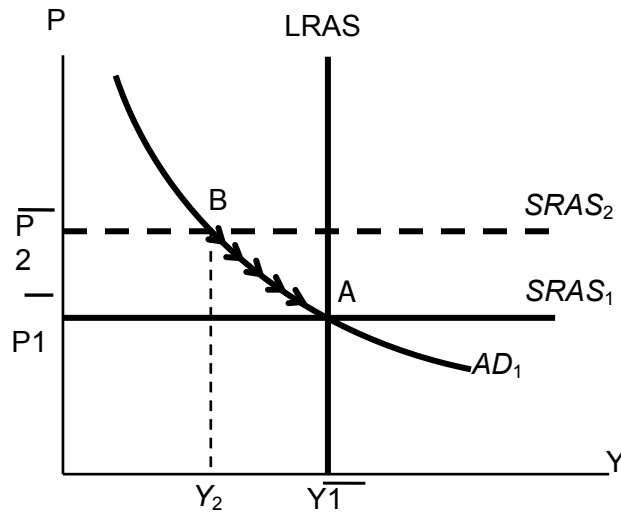

Predicted effects of the oil price shock:

- Inflation \uparrow
- Output \downarrow
- Unemployment \uparrow

...and then a gradual recovery.



▲ Change in oil prices (left scale) ● Inflation rate-CPI (right scale)

■ Unemployment rate (right scale)

Late 1970s: As economy was recovering, oil prices shot up again, causing another huge supply shock!!!

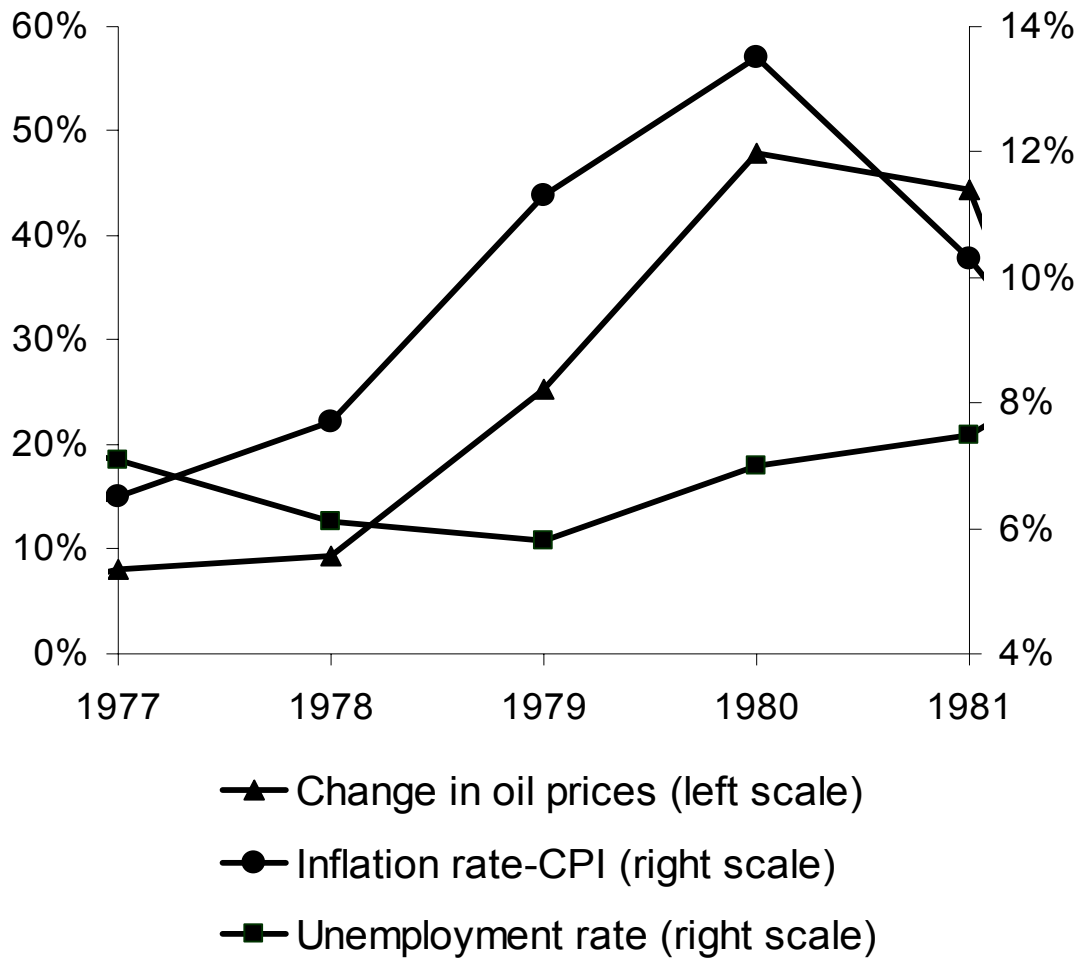

The 1980s oil shocks

1980s: A favorable supply shock--a significant fall in oil prices.

As the model would predict, inflation and unemployment fell:

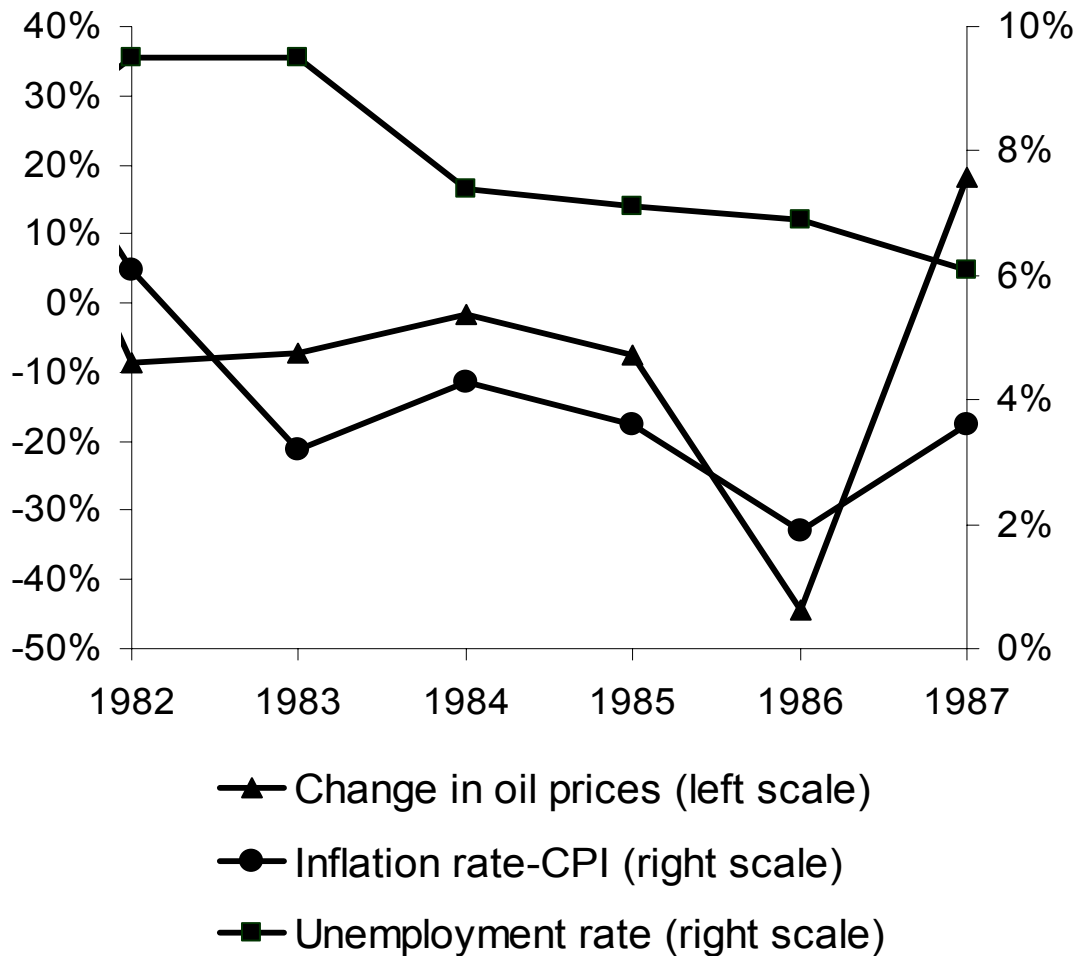

Keynesian theory of Income & Employment

- Model of aggregate demand & aggregate supply
- Long run
 - Prices flexible
 - Output determined by factors of production & technology
 - Unemployment equals its natural rate
- Short run
 - Prices fixed
 - Output determined by aggregate demand
 - Unemployment is negatively related to output

AGGREGATE DEMAND AND AGGREGATE SUPPLY (Continued...)

Context

- Model of aggregate demand & aggregate supply
- Long run
 - Prices flexible
 - Output determined by factors of production & technology
 - Unemployment equals its natural rate
- Short run
 - Prices fixed
 - Output determined by aggregate demand
 - Unemployment is negatively related to output
- Now, we develop the IS-LM model, the theory that yields the aggregate demand curve. We focus on the short run and assume the price level is fixed.

The Keynesian Cross

- A simple closed economy model in which income is determined by expenditure. (due to J.M. Keynes)
- Notation:

I = planned investment

$E = C + I + G$ = planned expenditure

Y = real GDP = actual expenditure

- Difference between actual & planned expenditure: unplanned inventory investment

Elements of the Keynesian Cross

Consumption function:

$$C = C(Y - T)$$

Govt policy variables:

$$G = \bar{G}, \quad T = \bar{T}$$

For now, investment is exogenous:

$$I = \bar{I}$$

Planned expenditure:

$$E = C(Y - \bar{T}) + \bar{I} + \bar{G}$$

Equilibrium condition:

$$\text{Actual expenditure} = \text{Planned expenditure}$$

$$Y = E$$

Graphing planned expenditure

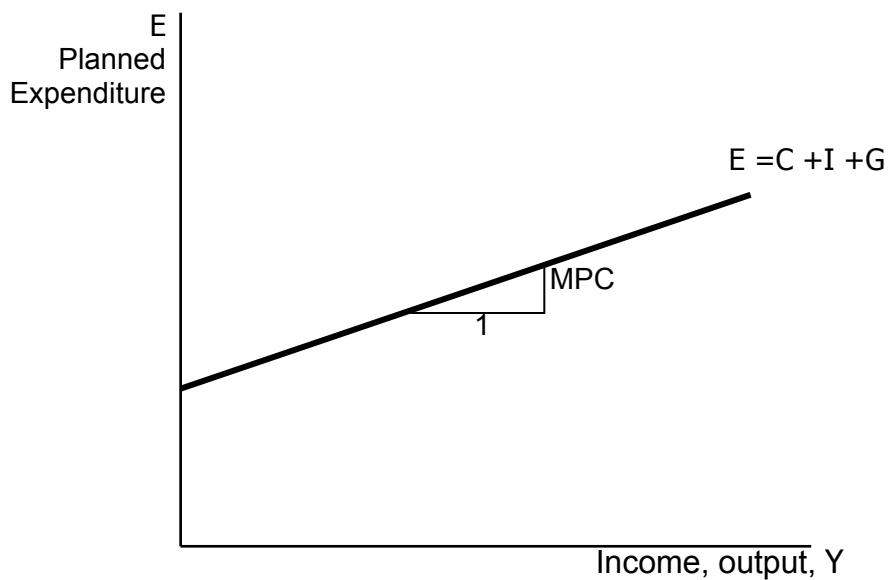

Graphing the equilibrium condition

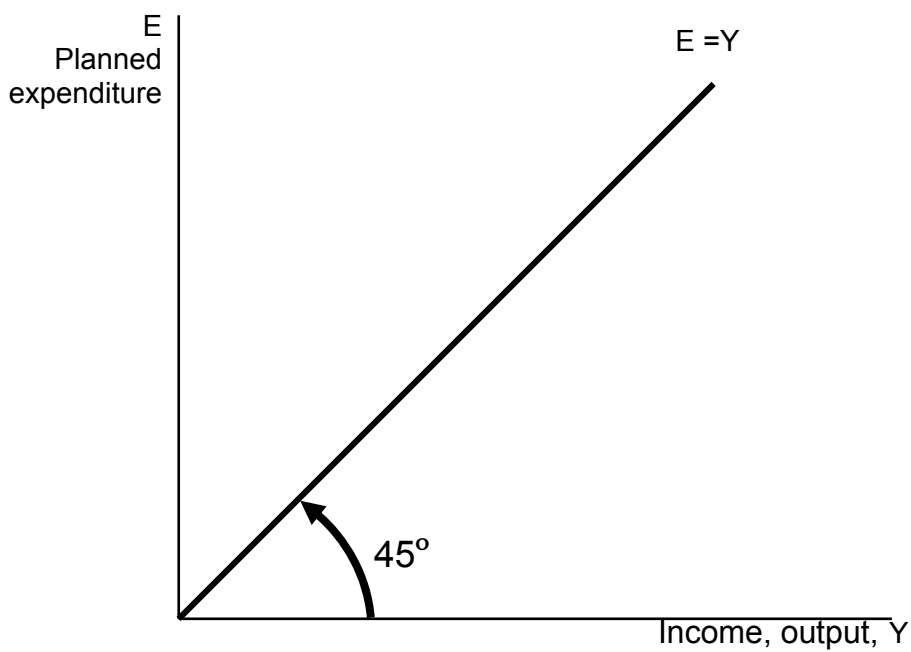

The equilibrium value of income

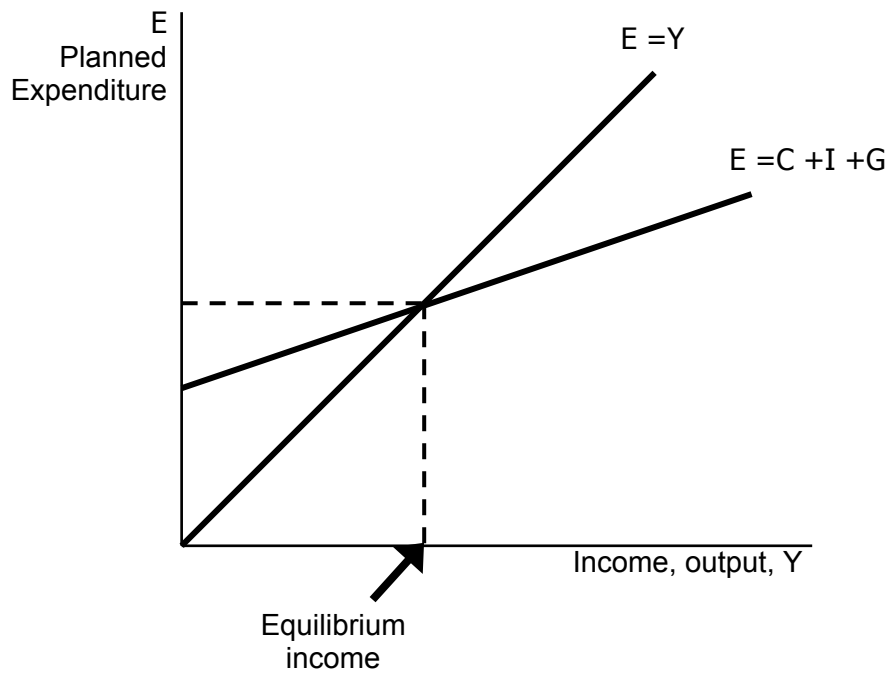

An increase in government purchases

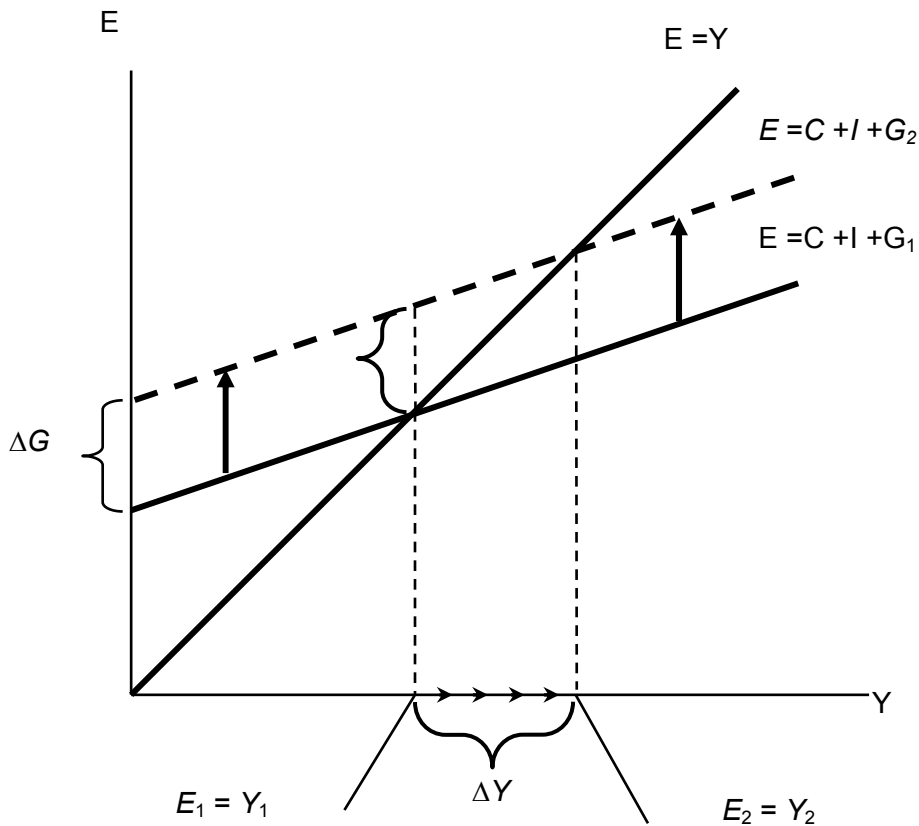

At Y_1 , there is now an unplanned drop in inventory, so firms increase output, and income rises toward a new equilibrium

Solving for ΔY

Equilibrium condition

$$Y = C + I + G$$

In changes form

$$\Delta Y = \Delta C + \Delta I + \Delta G$$

Since I is exogenous

$$= \Delta C + \Delta G$$

Because $\Delta C = MPC \Delta Y$

$$= MPC \times \Delta Y + \Delta G$$

Collect terms with ΔY on the left side of the equals sign:

$$(1 - MPC) \times \Delta Y = \Delta G$$

Finally, solve for ΔY :

$$\Delta Y = \left(\frac{1}{1 - MPC} \right) \times \Delta G$$

The government purchases multiplier

Example: $MPC = 0.8$

$$\begin{aligned} \Delta Y &= \frac{1}{1 - MPC} \Delta G \\ &= \frac{1}{1 - 0.8} \Delta G = \frac{1}{0.2} \Delta G = 5 \Delta G \end{aligned}$$

The increase in G causes income to increase by 5 times as much!

Definition: the increase in income resulting from a Re.1 increase in G . In this model, the G multiplier equals

$$\frac{\Delta Y}{\Delta G} = \frac{1}{1 - MPC}$$

In the example with $MPC = 0.8$,

$$\frac{\Delta Y}{\Delta G} = \frac{1}{1 - MPC}$$

Why the multiplier is greater than 1

- Initially, the increase in G causes an equal increase in Y : $\Delta Y = \Delta G$.

- But $\uparrow Y \Rightarrow \uparrow C$

\Rightarrow Further $\uparrow Y$

\Rightarrow Further $\uparrow C$

\Rightarrow Further $\uparrow Y$

- So the final impact on income is much bigger than the initial ΔG .

An increase in taxes

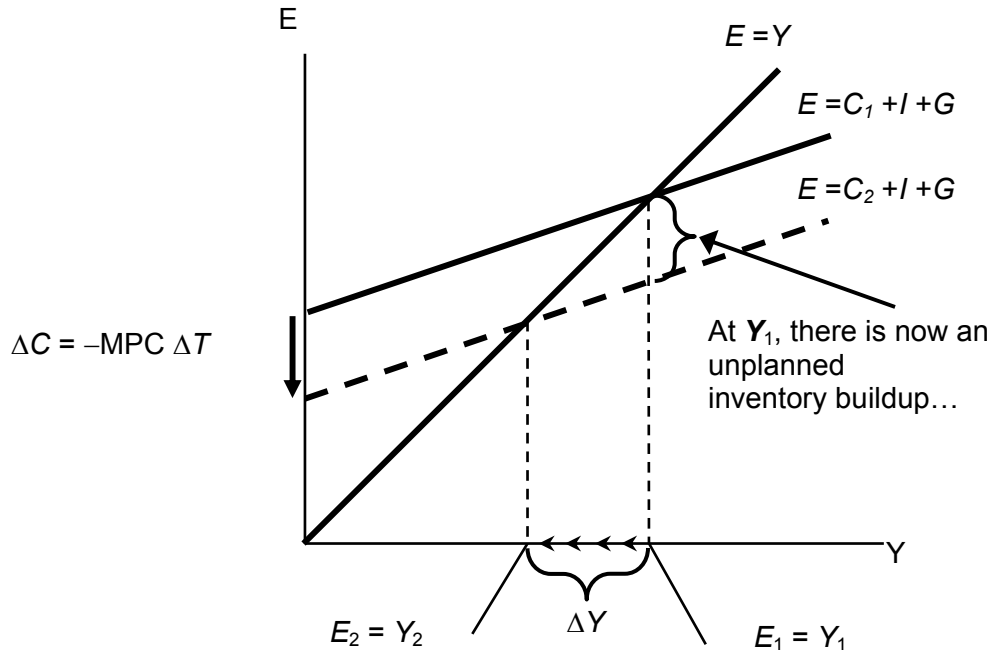

Initially, the tax increase reduces consumption, and therefore **E**: so firms reduce output, and income falls toward a new equilibrium

Solving for ΔY

Equilibrium condition in changes

$$\Delta Y = \Delta C + \Delta I + \Delta G$$

I and G are exogenous

$$= \Delta C$$

$$= MPC \times (\Delta Y - \Delta T)$$

Solving for ΔY:

$$(1 - MPC) \times \Delta Y = -MPC \times \Delta T$$

Final result:

$$\Delta Y = \left(\frac{-MPC}{1 - MPC} \right) \times \Delta T$$

The Tax Multiplier

Definition: the change in income resulting from a \$1 increase in T:

$$\frac{\Delta Y}{\Delta T} = \frac{-MPC}{1 - MPC}$$

If MPC = 0.8, then the tax multiplier equals

$$\frac{\Delta Y}{\Delta T} = \frac{-0.8}{1 - 0.8} = \frac{-0.8}{0.2} = -4$$

Properties of Tax Multiplier

- 1. Tax multiplier is negative:** A tax hike reduces consumer spending, which reduces income.

- 2. **Tax multiplier is greater than one (in absolute value):** A change in taxes has a multiplier effect on income.
- 3. **Tax multiplier is smaller than the govt. spending multiplier:** Consumers save the fraction $(1-MPC)$ of a tax cut, so the initial boost in spending from a tax cut is smaller than from an equal increase in G .

The IS curve

Definition: a graph of all combinations of r and Y that result in goods market equilibrium,

i.e. *actual expenditure (output) = planned expenditure*

The equation for the IS curve is:

$$Y = C(Y - \bar{T}) + I(r) + \bar{G}$$

Deriving the IS curve

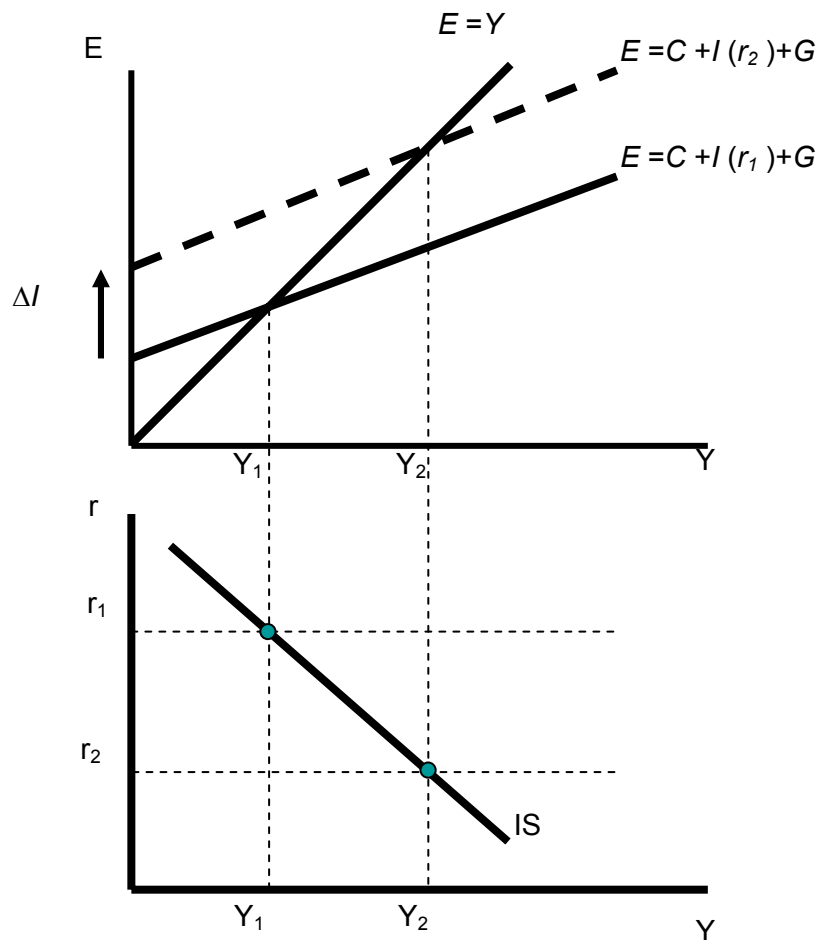

$\downarrow r$ $\Rightarrow \uparrow I$
 $\Rightarrow \uparrow E$
 $\Rightarrow \uparrow Y$

LESSON 27

AGGREGATE DEMAND AND AGGREGATE SUPPLY (Continued...)**Understanding the IS curve's slope**

- The IS curve is negatively sloped.
- Intuition:
A fall in the interest rate motivates firms to increase investment spending, which drives up total planned spending (E).

To restore equilibrium in the goods market, output (actual expenditure, Y) must increase.

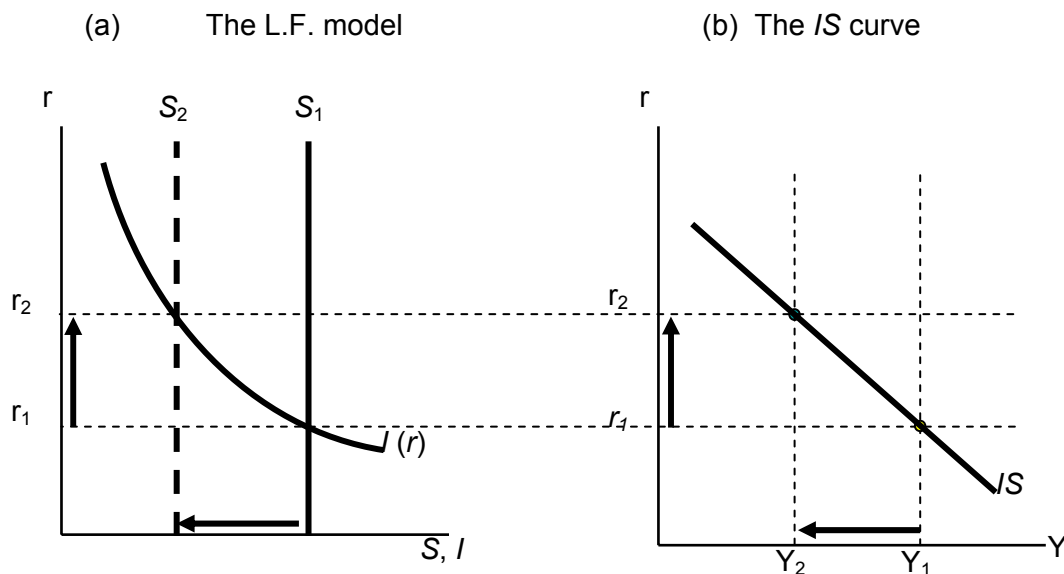
The IS curve and the Loanable Funds model**Fiscal Policy and the IS curve**

- We can use the IS-LM model to see how fiscal policy (G and T) can affect aggregate demand and output.
- Let's start by using the Keynesian Cross to see how fiscal policy shifts the IS curve...

Shifting the IS curve: ΔG

At any value of r , $\uparrow G \Rightarrow \uparrow E \Rightarrow \uparrow Y$...so the IS curve shifts to the right.

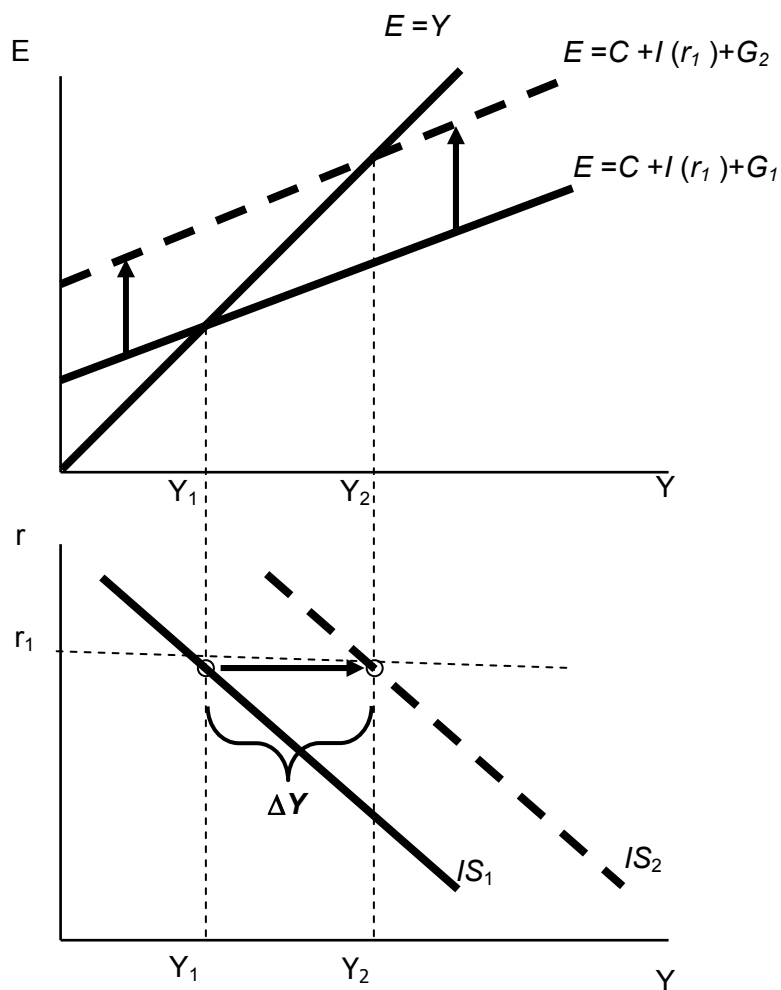

The Theory of Liquidity Preference

- Due to John Maynard Keynes.
- A simple theory in which the interest rate is determined by money supply and money demand.

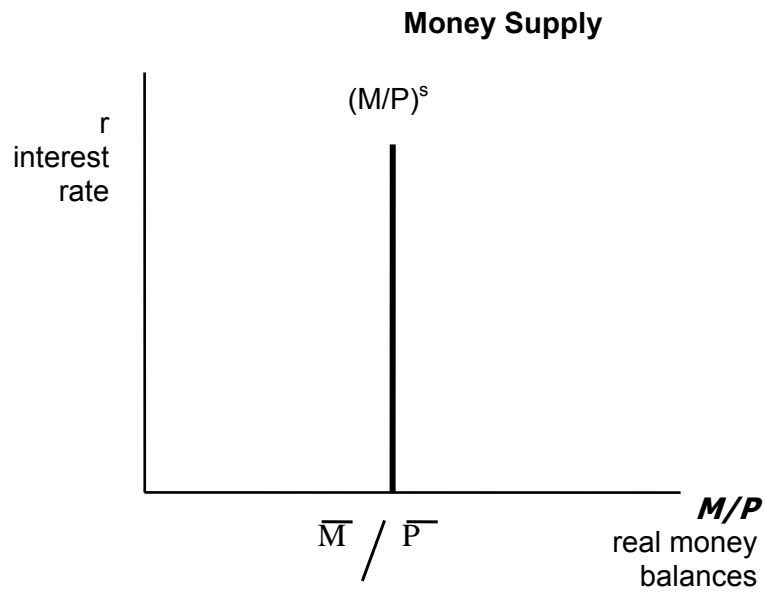

The supply of real money balances is fixed:

$$(M/P)^s = \bar{M} / \bar{P}$$

Money Demand

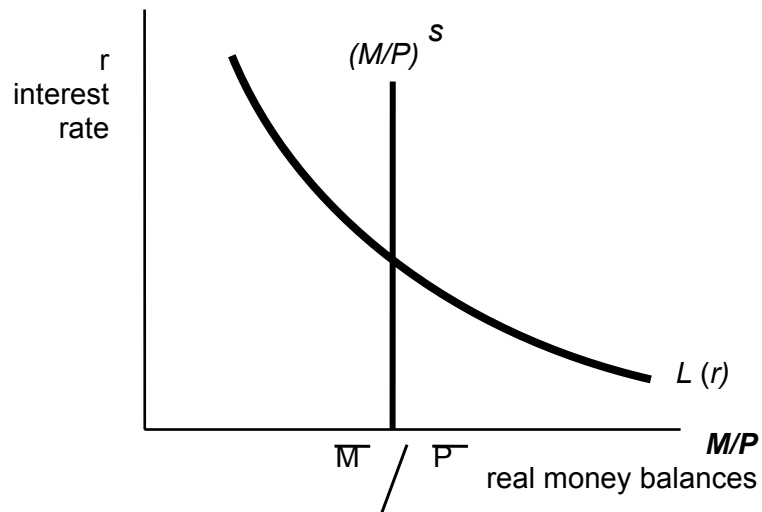

Demand for real money balances:

$$(M/P)^d = L(r)$$

Equilibrium

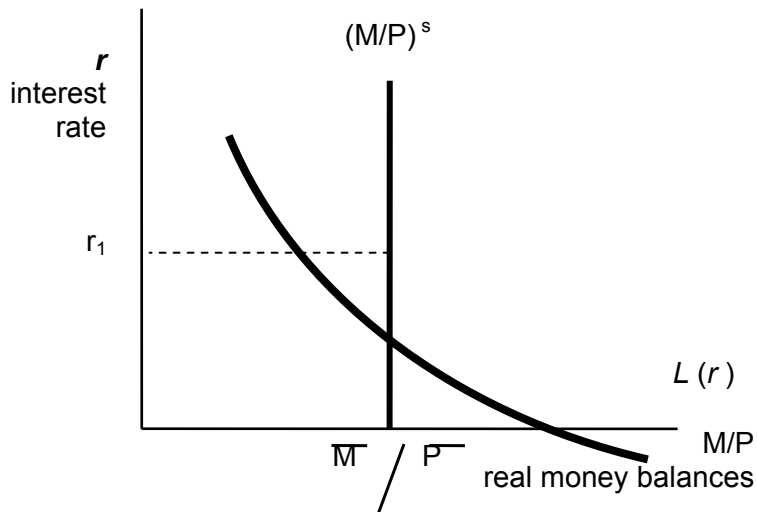

The interest rate adjusts to equate the supply and demand for money:

$$\overline{M/P} = L(r)$$

How Central bank raises the interest rate

To increase r , Central Bank reduces M

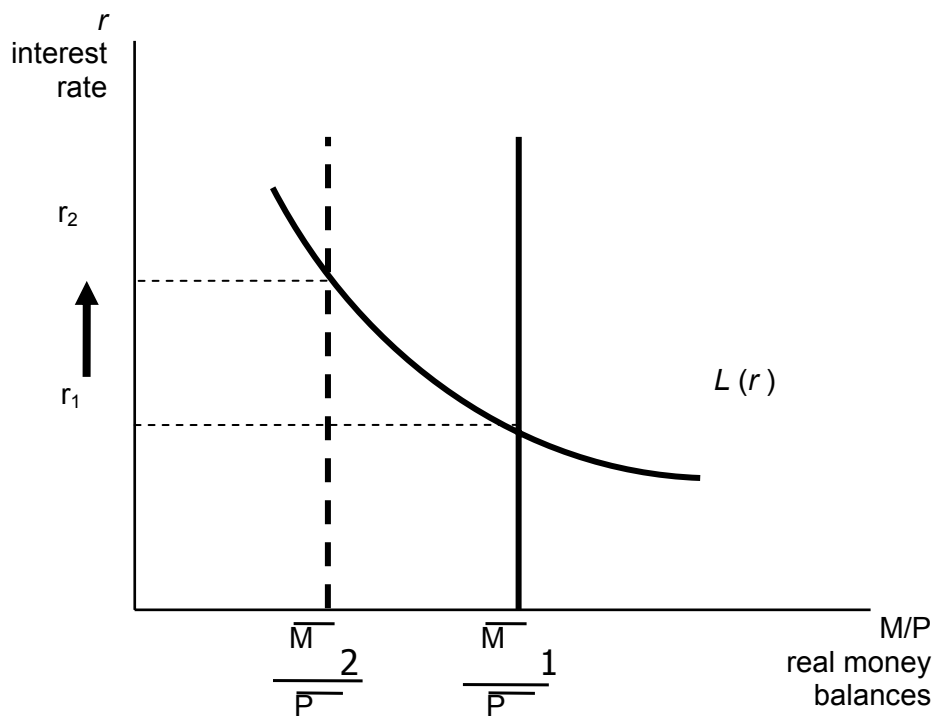

The LM curve

Now let's put Y back into the money demand function:

$$(M/P)^d = L(r, Y)$$

The LM curve is a graph of all combinations of r and Y that equate the supply and demand for real money balances.

The equation for the LM curve is:

$$\bar{M}/\bar{P} = L(r, Y)$$

Deriving the LM curve

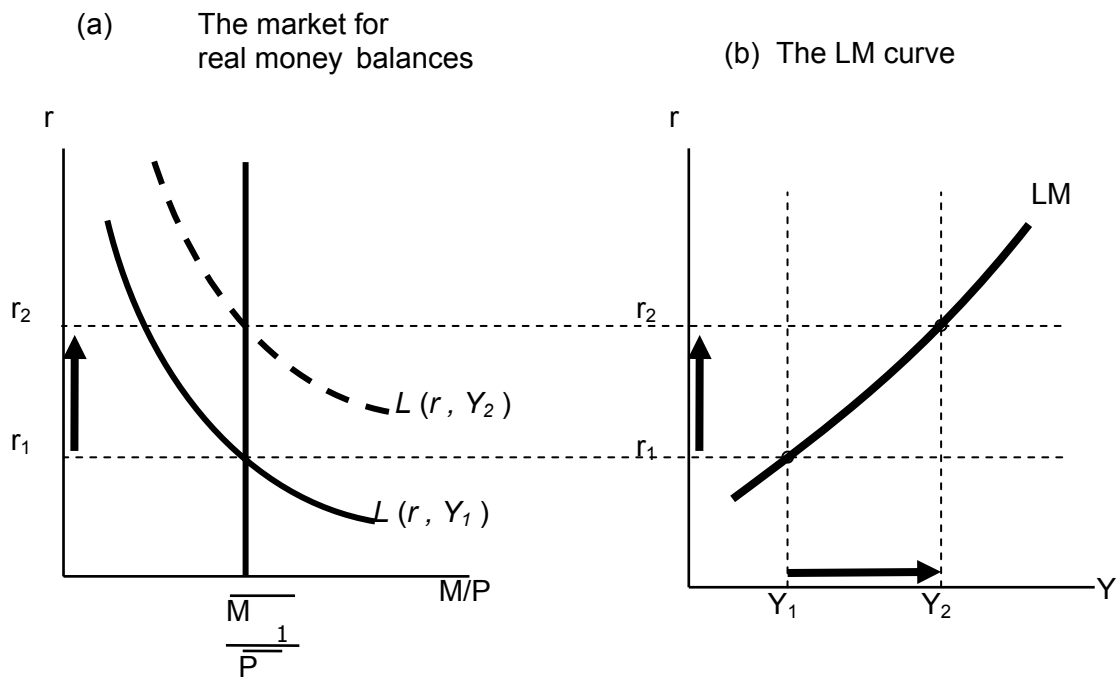

Understanding the LM curve's slope

- The LM curve is positively sloped.
- **Intuition:** An increase in income raises money demand. Since the supply of real balances is fixed, there is now excess demand in the money market at the initial interest rate.

The interest rate must rise to restore equilibrium in the money market.

How ΔM shifts the LM curve

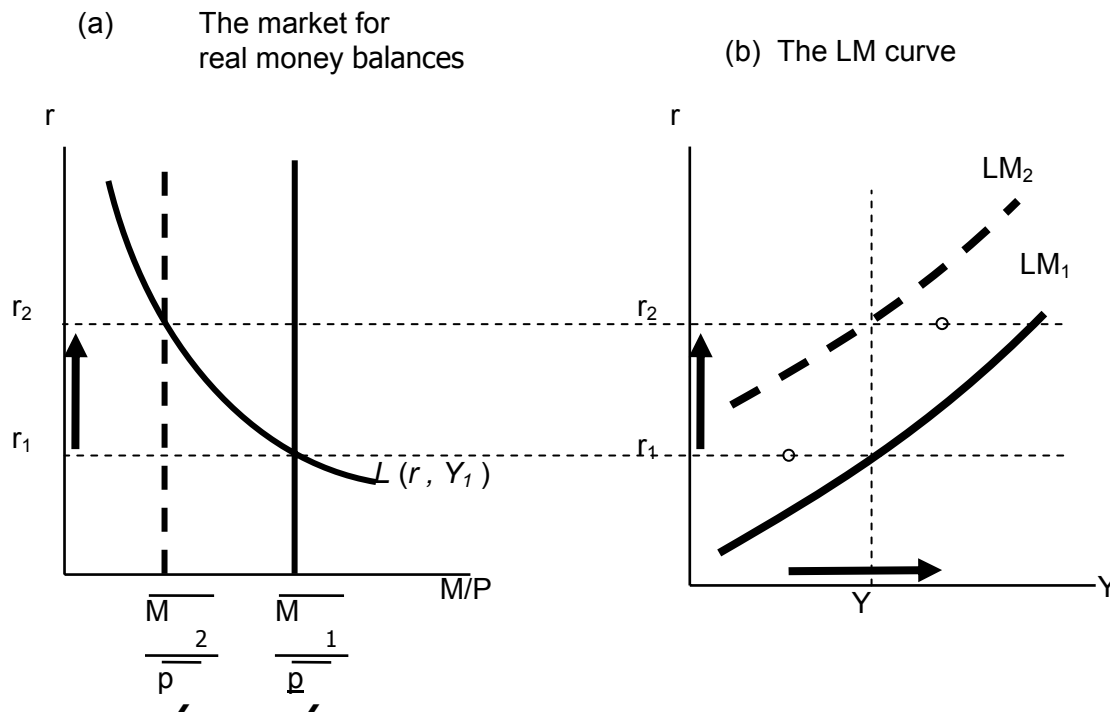

Shifting the LM curve

- Suppose a wave of credit card fraud causes consumers to use cash more frequently in transactions.
- Use the Liquidity Preference model to show how these events shift the LM curve.

The short-run equilibrium

The short-run equilibrium is the combination of r and Y that simultaneously satisfies the equilibrium conditions in the goods & money markets:

$$Y = C(Y - \bar{T}) + I(r) + \bar{G}$$

$$\bar{M}/\bar{P} = L(r, Y)$$

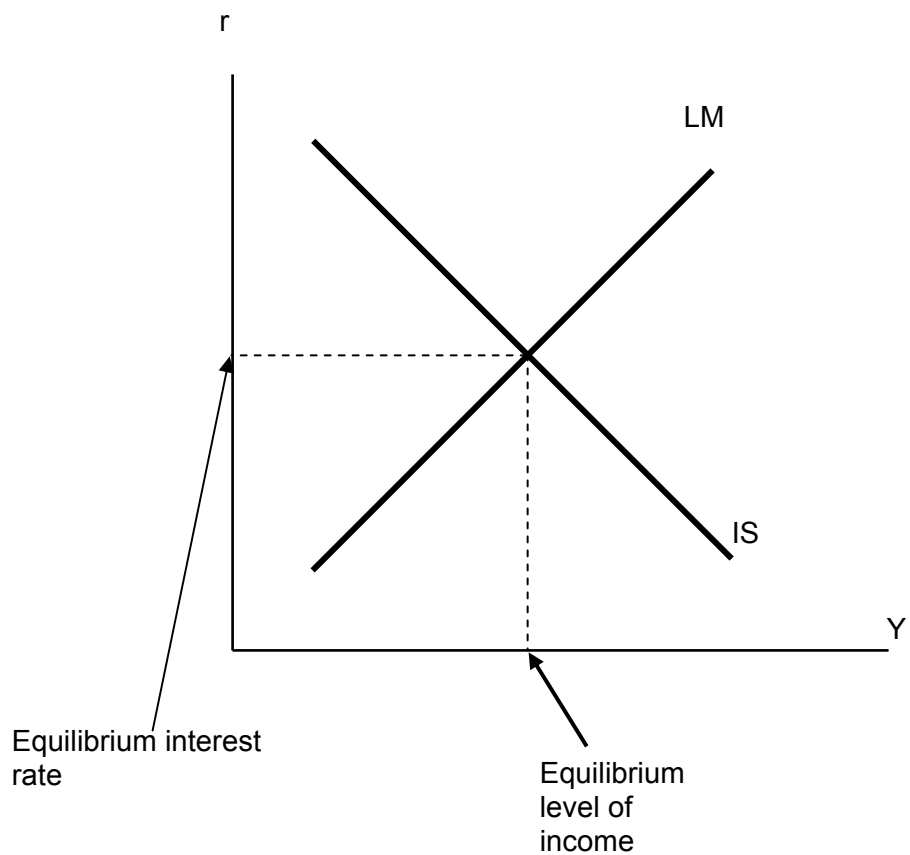

LESSON 28

AGGREGATE DEMAND AND AGGREGATE SUPPLY (Continued...)

The Big Picture

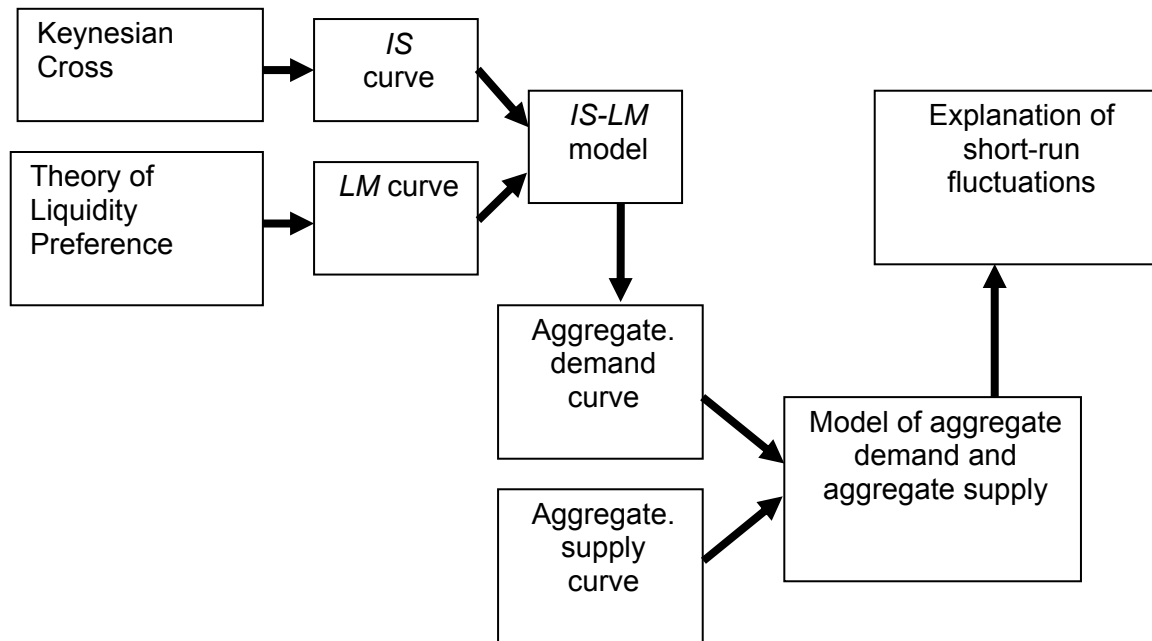

Equilibrium in the IS-LM Model

The IS curve represents equilibrium in the goods market.

$$Y = C(Y - \bar{T}) + I(r) + \bar{G}$$

The LM curve represents money market equilibrium

$$\bar{M}/\bar{P} = L(r, Y)$$

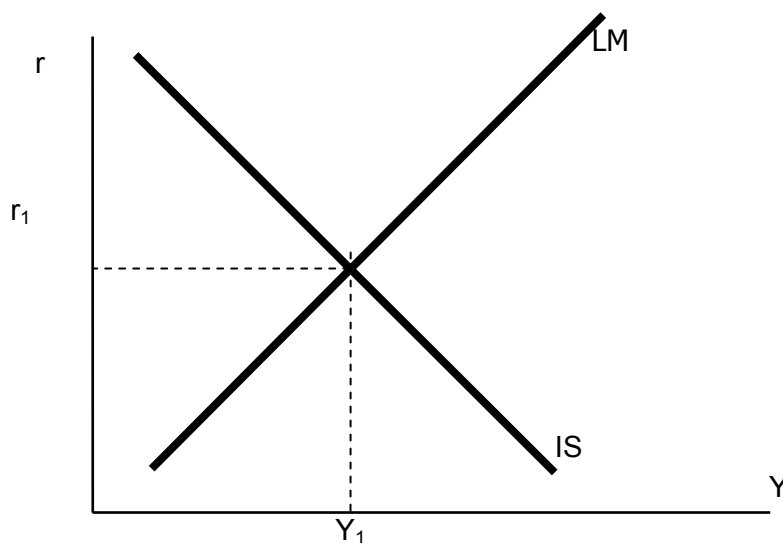

The intersection determines the unique combination of Y and r that satisfies equilibrium in both markets.

Policy analysis with the IS-LM Model

Policymakers can affect macroeconomic variables with

- fiscal policy: G and/or T
- monetary policy: M

We can use the IS-LM model to analyze the effects of these policies.

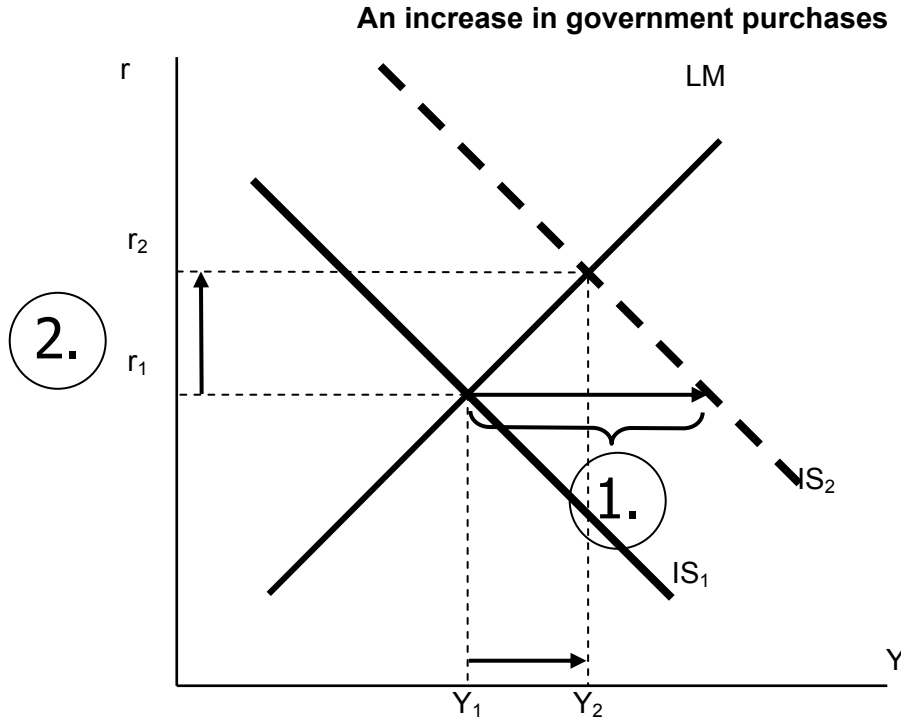

3.
↑

1. IS curve shifts right by $(1-MPC) \Delta G$, causing output & income to rise.
2. This raises money demand, causing the interest rate to rise $\frac{1}{(1-MPC)}$
3. ...which reduces investment, so the final increase in Y is smaller than $\frac{1}{(1-MPC)} \Delta G$.

A tax cut

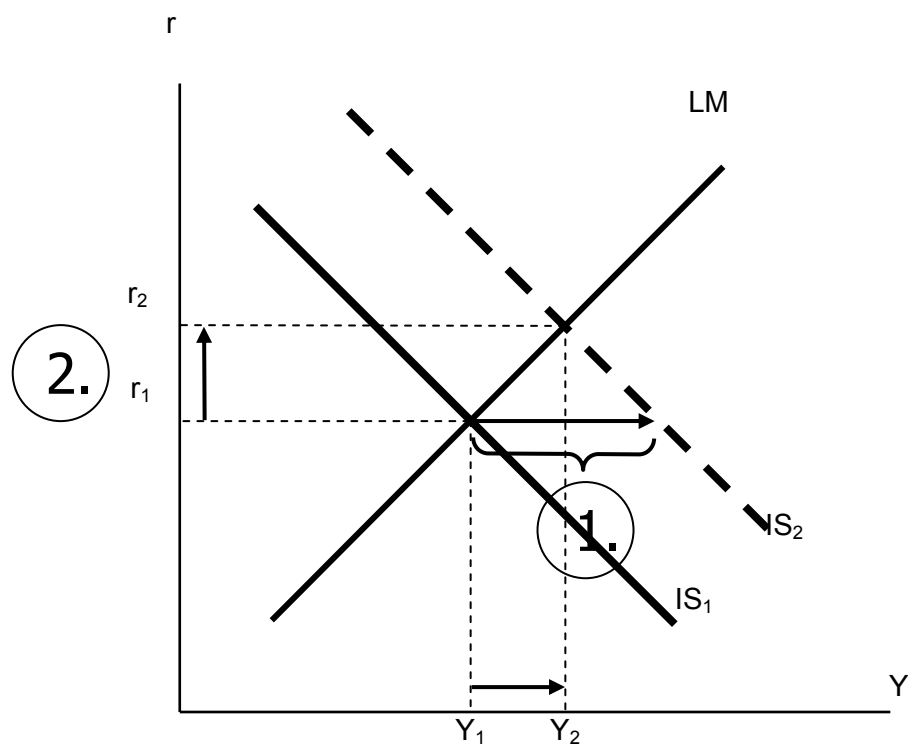

2.

Because consumers save $(1-MPC)$ of the tax cut, the initial boost in spending is smaller for ΔT than for an equal ΔG ... and the IS curve shifts by

1. $\frac{1}{(1-MPC)} \Delta T$

2. ...so the effects on r and Y are smaller for a ΔT than for an equal ΔG .

Monetary Policy: an increase in M

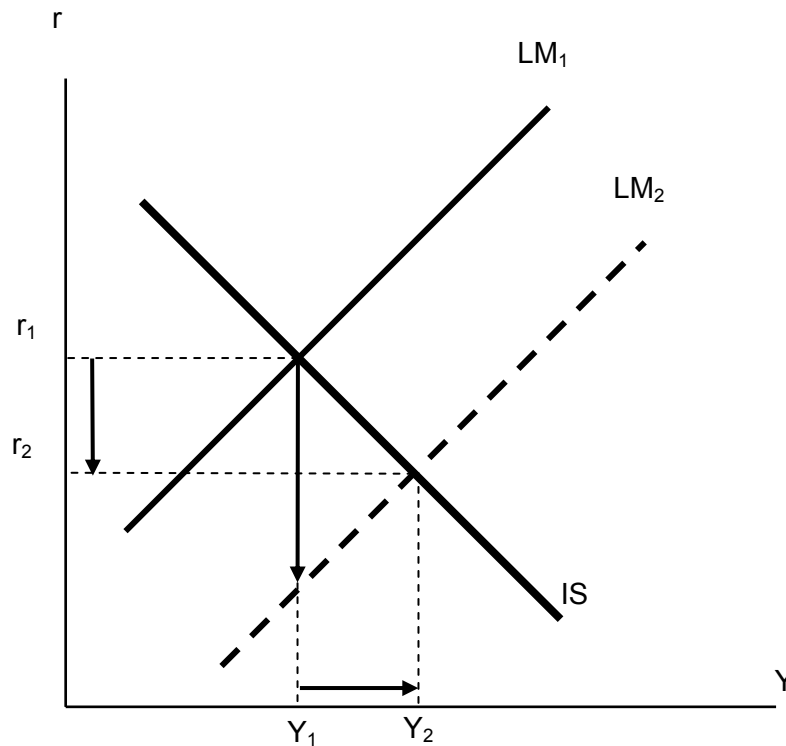

1. $\Delta M > 0$ shifts the LM curve down (or to the right)
2. ...causing the interest rate to fall
3. ...this increases investment, causing output & income to rise.

Interaction between monetary & fiscal policy

- Model: monetary & fiscal policy variables (M , G and T) are exogenous
- Real world: Monetary policymakers may adjust M in response to changes in fiscal policy, or vice versa.
- Such interaction may alter the impact of the original policy change.

Central Bank's response to $\Delta G > 0$

- Suppose Government increases G .
- Possible central bank responses:
 1. Hold M constant
 2. Hold r constant
 3. Hold Y constant
- In each case, the effects of the ΔG are different:

Response 1: hold M constant

If Government raises G , the IS curve shifts right. If central bank holds M constant, then LM curve doesn't shift.

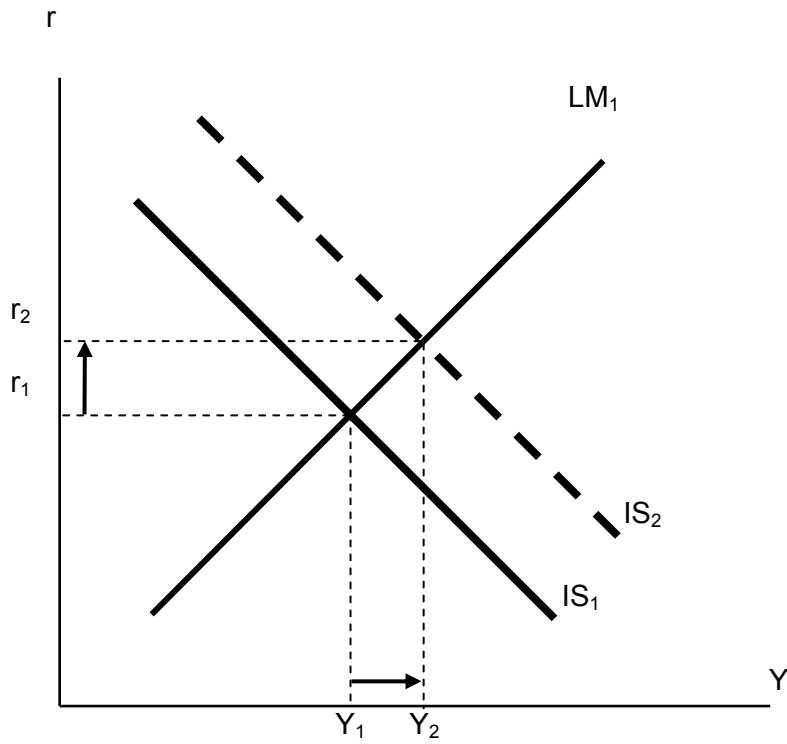

Results:

$$\Delta Y = Y_2 - Y_1 \quad \Delta r = r_2 - r_1$$

Response 2A: hold r constant

If Government raises G , the IS curve shifts right. To keep r constant, central bank increases M

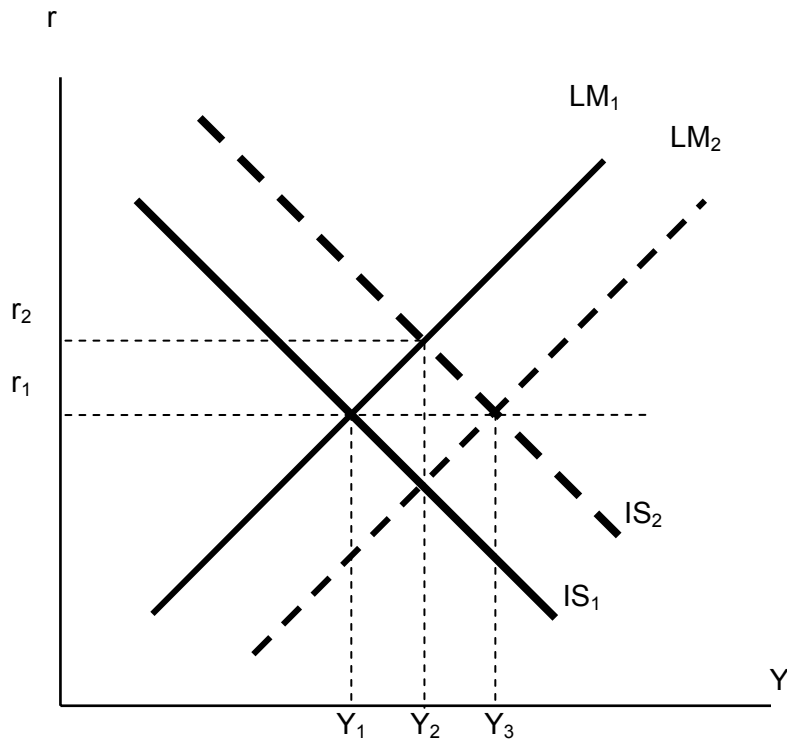

to shift LM curve right.

Results: $\Delta Y = Y_3 - Y_1$ $\Delta r = 0$

Response2B: hold Y constant

If Government raises G, the IS curve shifts right. To keep Y constant, central Bank reduces M to shift LM curve left.

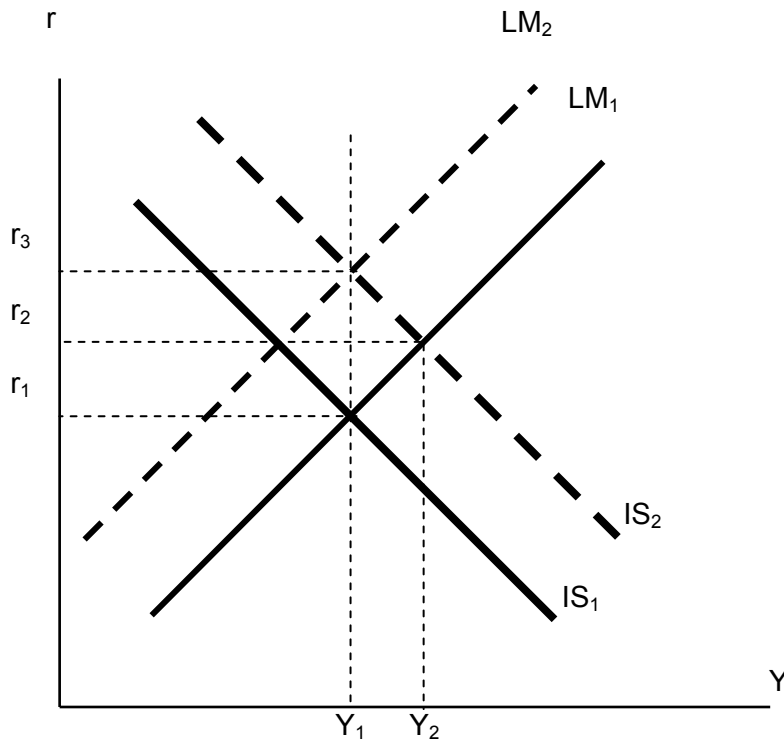

Results: $\Delta Y = 0$ $\Delta r = r_3 - r_1$

Shocks in the IS-LM Model

IS shocks: exogenous changes in the demand for goods & services.

Examples:

- Stock market boom or crash
 \Rightarrow change in households' wealth
 $\Rightarrow \Delta C$
- Change in business or consumer confidence or expectations
 $\Rightarrow \Delta I$ and/or ΔC

LM shocks: exogenous changes in the demand for money.

Examples:

- A wave of credit card fraud increases demand for money
- More ATMs or the Internet reduce money demand

Analyzing shocks with the IS-LM model

Use the IS-LM model to analyze the effects of

- A boom in the stock market makes consumers wealthier.
- After a wave of credit card fraud, consumers use cash more frequently in transactions.

For each shock,

- Use the *IS-LM* diagram to show the effects of the shock on Y and r .
- Determine what happens to C , I , and the unemployment rate.

What is the central bank's policy instrument?

- What the newspaper says:
"The central bank lowered interest rates by one-half point today"
- What actually happened:
The central bank conducted expansionary monetary policy to shift the LM curve to the right until the interest rate fell 0.5 points.
- The central bank targets the discount rate: it announces a target value, and uses monetary policy to shift the LM curve as needed to attain its target rate.

Why does the central bank target interest rates instead of the money supply?

- 1) They are easier to measure than the money supply
- 2) The central bank might believe that LM shocks are more prevalent than IS shocks. If so, then targeting the interest rate stabilizes income better than targeting the money supply.

IS-LM and Aggregate Demand

- So far, we've been using the *IS-LM* model to analyze the short run, when the price level is assumed fixed.
- However, a change in P would shift the *LM* curve and therefore affect Y .
- The aggregate demand curve captures this relationship between P and Y

Deriving the *AD* curve

Intuition for slope of *AD* curve:

$\uparrow P \Rightarrow \downarrow (M/P)$
 $\Rightarrow LM$ shifts left
 $\Rightarrow \uparrow r$
 $\Rightarrow \downarrow I$
 $\Rightarrow \downarrow Y$

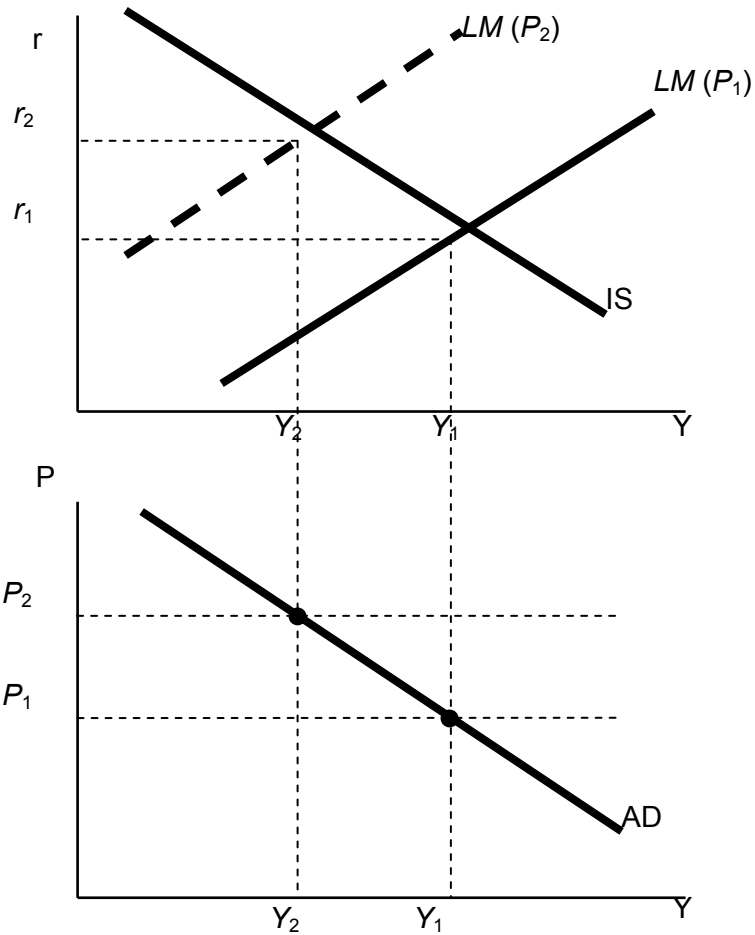

Monetary policy and the AD curve

The central bank can increase aggregate demand:

- $\uparrow M \Rightarrow LM$ shifts right
- $\Rightarrow \downarrow r$
- $\Rightarrow \uparrow I$
- $\Rightarrow \uparrow Y$ at each value of P

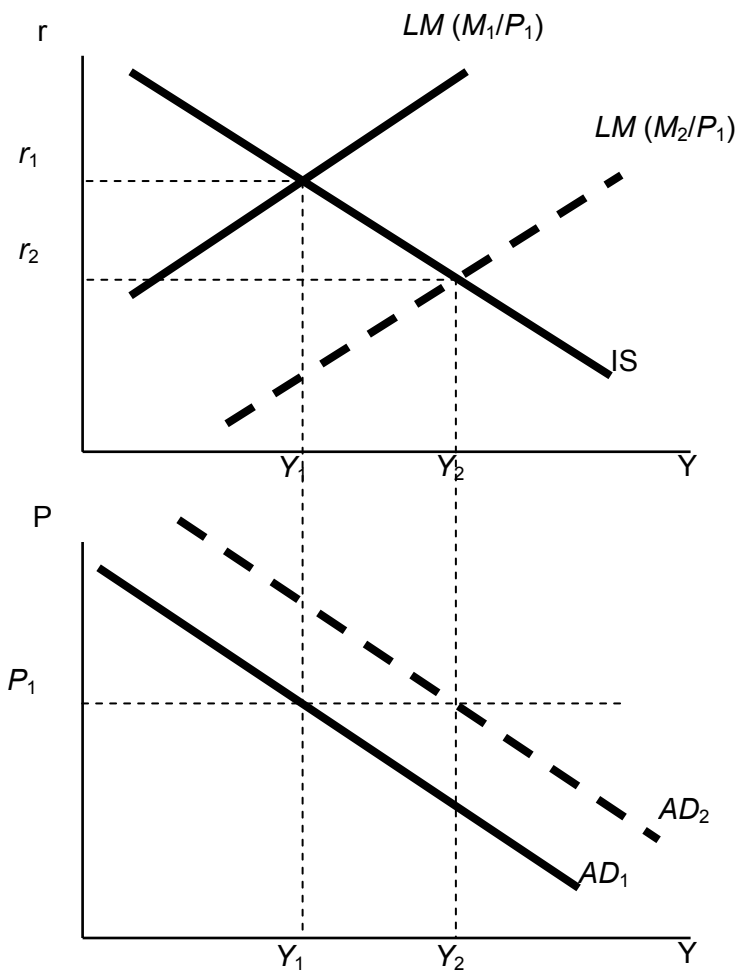

Fiscal policy and the AD curve

Expansionary fiscal policy ($\uparrow G$ and/or $\downarrow T$) increases aggregate demand:

- $\downarrow T \Rightarrow \uparrow C$
- \Rightarrow IS shifts right
- $\Rightarrow \uparrow Y$ at each value of P

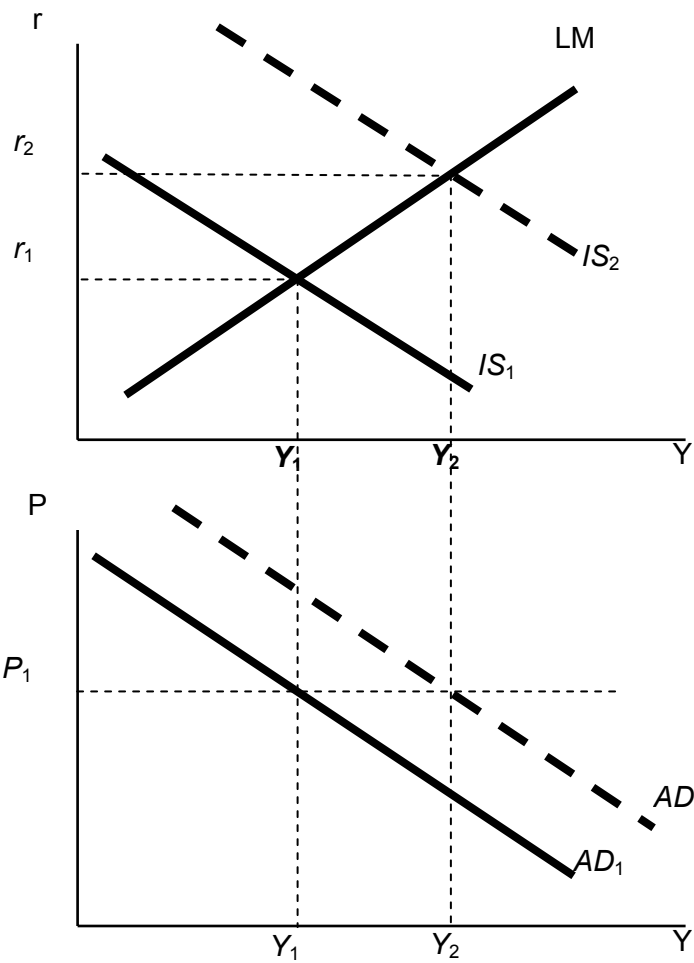

LESSON 29

AGGREGATE DEMAND AND AGGREGATE SUPPLY (Continued...)

IS-LM and Aggregate Demand

- So far, we've been using the *IS-LM* model to analyze the short run, when the price level is assumed fixed.
- However, a change in *P* would shift the *LM* curve and therefore affect *Y*.
- The aggregate demand curve captures this relationship between *P* and *Y*

Deriving the AD curve

Intuition for slope of AD curve:

- $\uparrow P \Rightarrow \downarrow (M/P)$
- $\Rightarrow LM$ shifts left
- $\Rightarrow \uparrow r$
- $\Rightarrow \downarrow I$
- $\Rightarrow \downarrow Y$

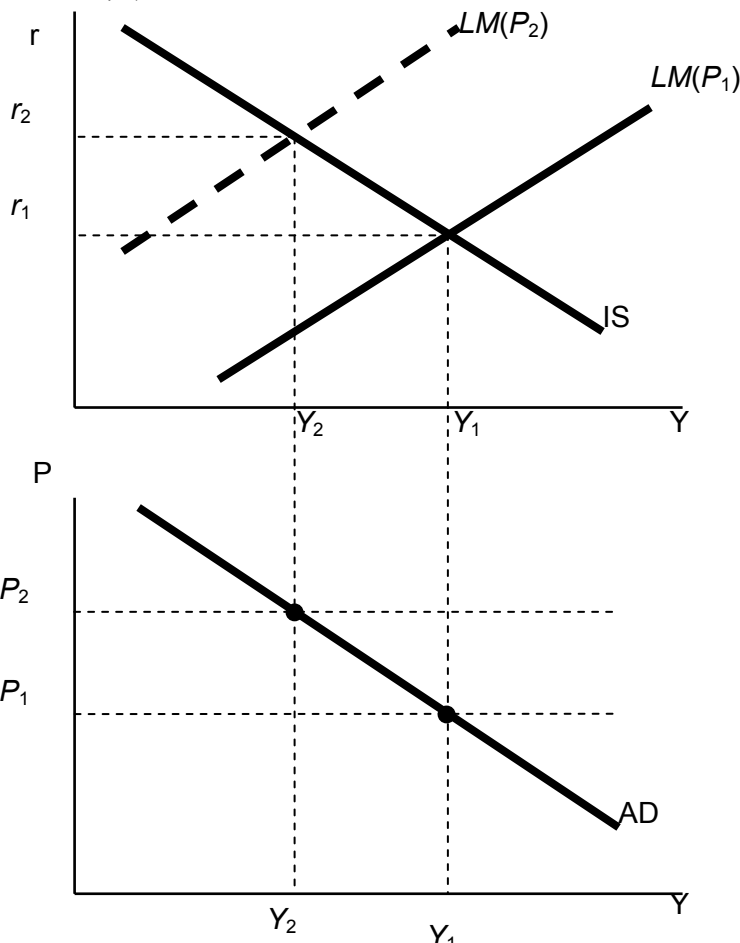

Monetary policy and the AD curve

The central bank can increase aggregate demand:

- $\uparrow M \Rightarrow LM$ shifts right
- $\Rightarrow \downarrow r$
- $\Rightarrow \uparrow I$
- $\Rightarrow \uparrow Y$ at each value of *P*

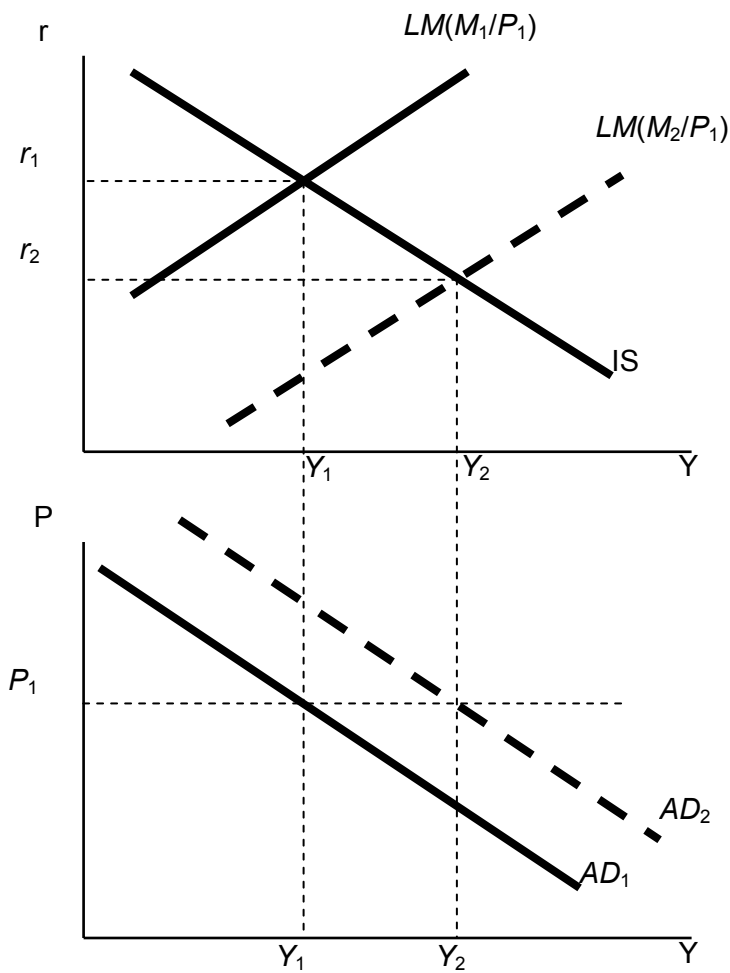

Fiscal policy and the AD curve

Expansionary fiscal policy ($\uparrow G$ and/or $\downarrow T$) increases aggregate demand:

- $\downarrow T \Rightarrow \uparrow C$
- \Rightarrow IS shifts right
- $\Rightarrow \uparrow Y$ at each value of P

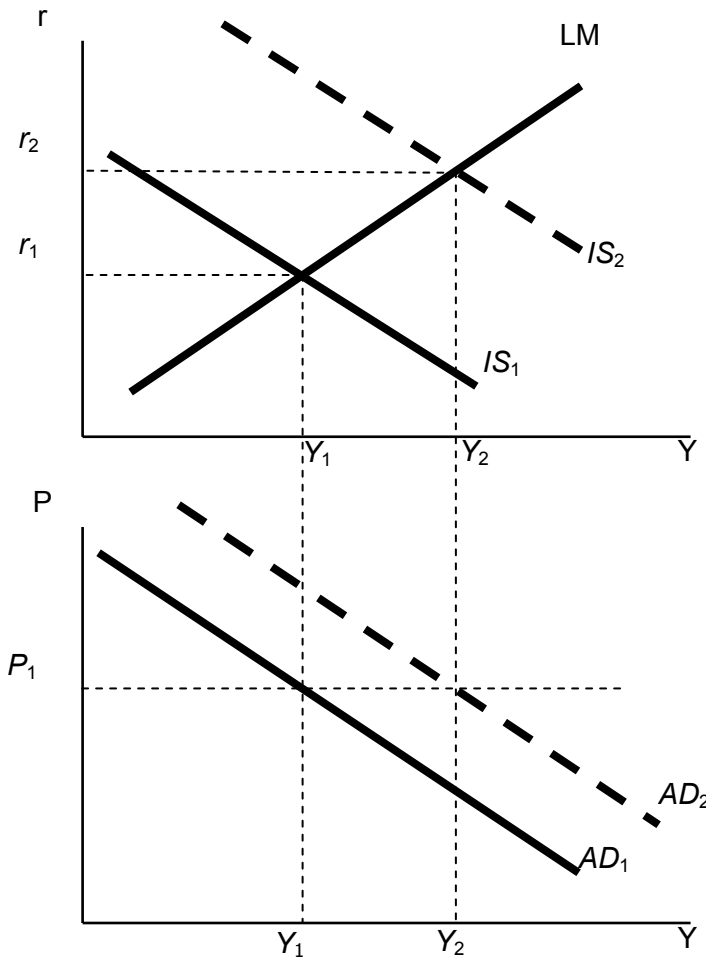

IS-LM and AD-AS in the short run & long run

Recall: The force that moves the economy from the short run to the long run is the gradual adjustment of prices.

In the short-run equilibrium, if	then over time, the price level will
$Y > \bar{Y}$	Rise
$Y < \bar{Y}$	Fall
$Y = \bar{Y}$	remain constant

The SR and LR effects of an IS shock

A negative IS shock shifts IS and AD left, causing Y to fall.

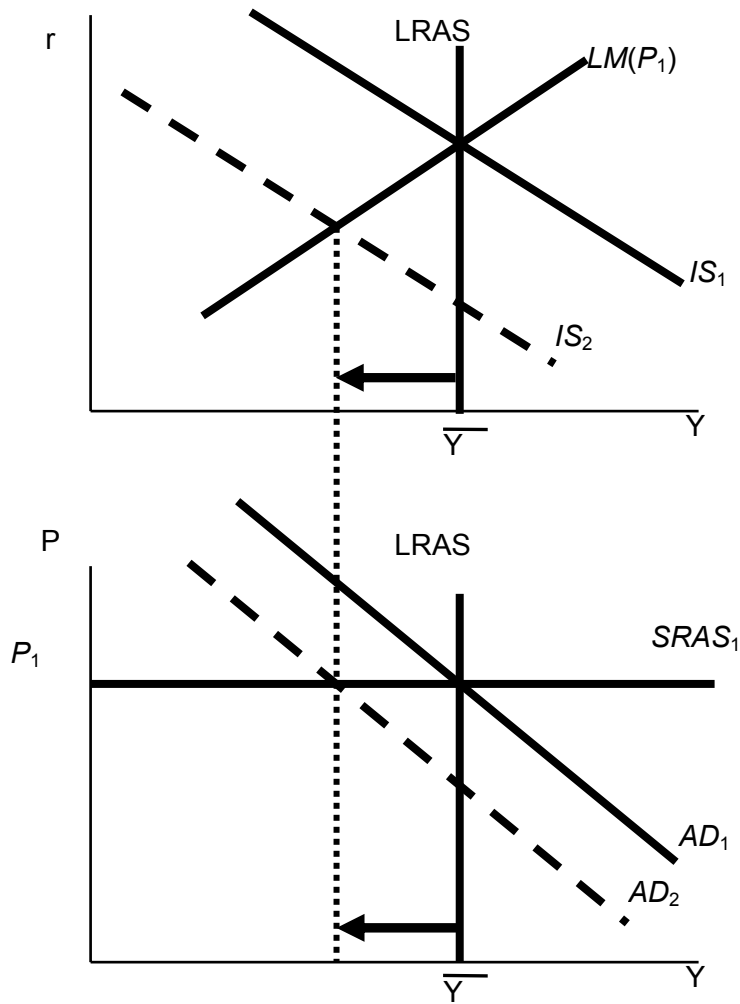

In the new short-run equilibrium, $Y < \bar{Y}$.

Over time, P gradually falls, which causes

- $SRAS$ to move down
- M/P to increase, which causes LM to move down

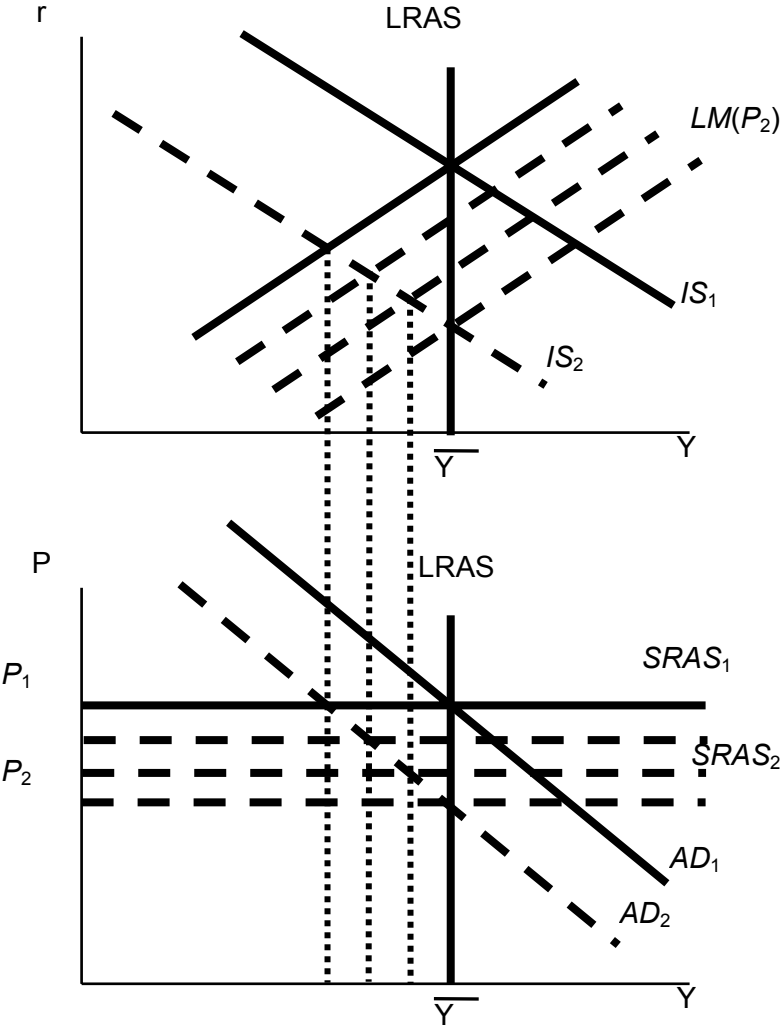

This process continues until economy reaches a long-run equilibrium with $Y = \bar{Y}$.

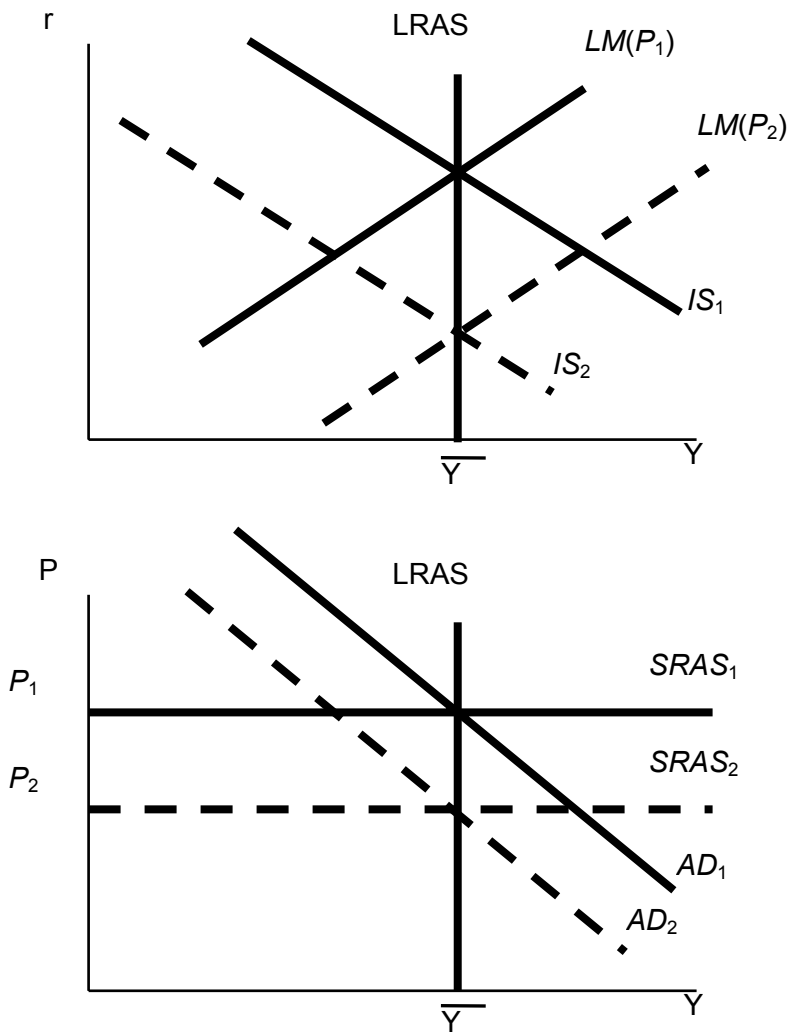

Short Run Impacts

Now it's time to determine the effects on the variables in the economy.

- Y +, because Y moved
- P 0, because prices are sticky in the SR.
- r +, because a + ΔY leads to a rise in r as IS slides along the LM curve.
- C +, because a + ΔY increases the level of consumption ($\uparrow C=C(\uparrow Y-T)$).
- I -, since r increased, the level of investment decreased.

Long Run Impacts

- Y 0, because rising P shifts LM to left, returning Y to Y^* as required by long-run LRAS.
- P +, in order to eliminate the excess demand at P_0 .
- r +, reflecting the leftward shift in LM due to + ΔP
- C 0, since both Y and T are back to their initial levels ($C=C(Y-T)$)
- I --, since r has risen even more due to the + ΔP .

Analyze SR & LR effects of ΔM

- We Have IS-LM and AD-AS diagrams as shown here.
- Suppose central bank increases M.

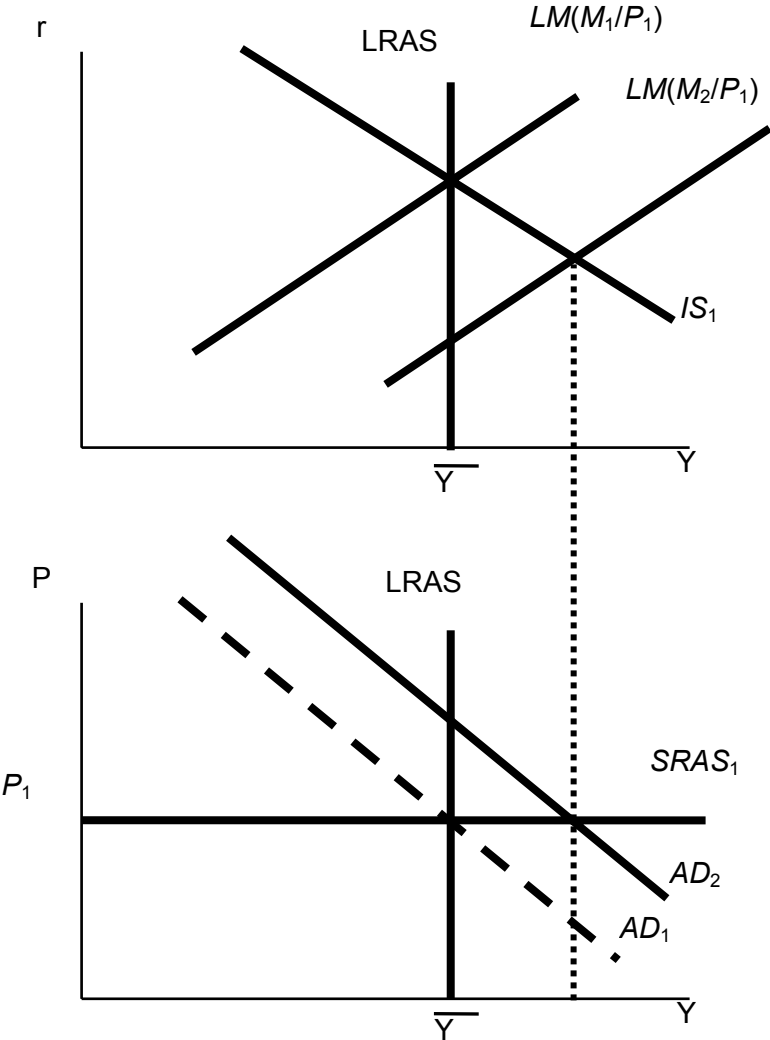

- The Graph below Shows the Short run effects of the change in M and what happens in the transition from the short run to the long run.

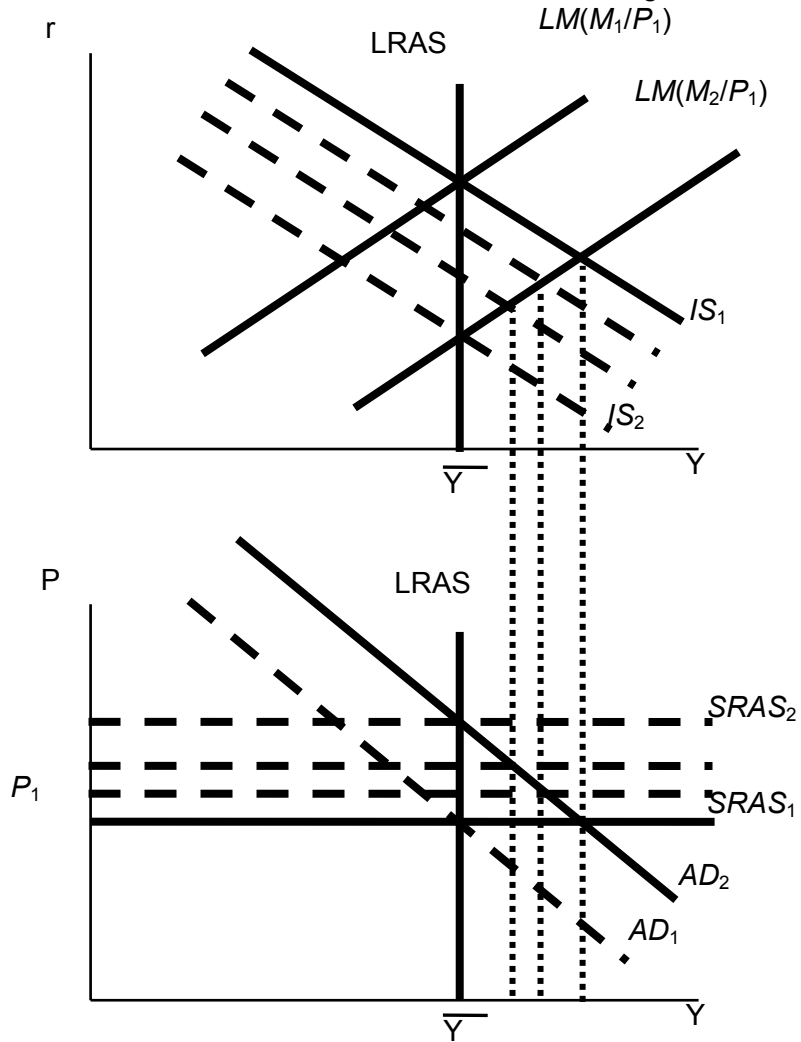

- The new long-run equilibrium values of the endogenous variables as compared to their initial values

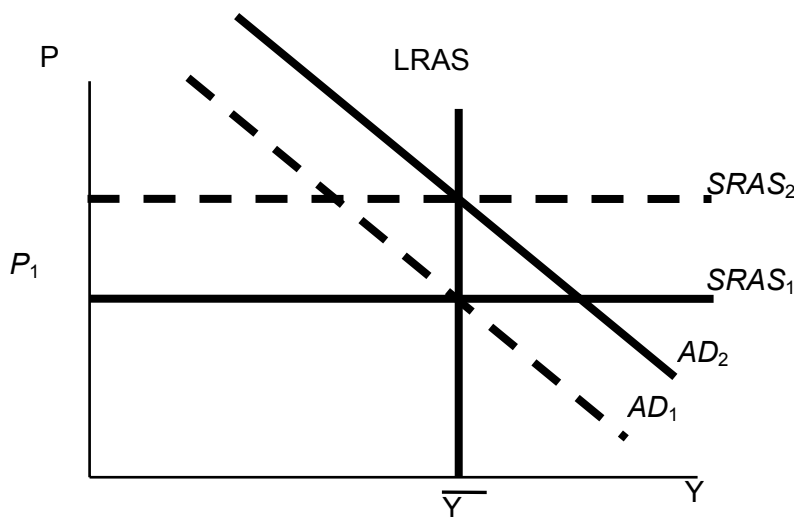
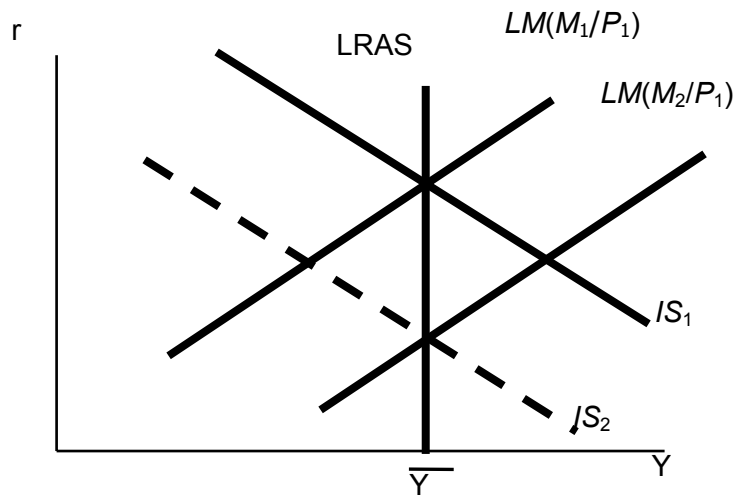

Short Run Impacts

Now it's time to determine the effects on the variables in the economy.

- Y +, because Y moved
- P 0, because prices are sticky in the SR.
- r -, because a + ΔY leads to a decrease in r as LM slides along the IS curve.
- C +, because a + ΔY increases the level of consumption ($\uparrow C=C(\uparrow Y-T)$).
- I +, since r decreased, the level of investment increased.

Long Run Impacts

- Y 0, because rising P shifts LM to left, returning Y to Y^* as required by long-run LRAS.
- P +, in order to eliminate the excess demand at P_0 .
- r 0, reflecting the leftward shift in LM due to + ΔP restoring r to its original level
- C 0, since both Y and T are back to their initial levels ($C=C(Y-T)$)
- I 0, since Y or r has not changed.

Notice that the only LR impact of an increase in the money supply was an increase in the price level.

AGGREGATE DEMAND IN THE OPEN ECONOMY

The Mundell-Fleming Model

The Mundell-Fleming model portrays the relationship between the nominal exchange rate and the economy output.

It is an extension of IS-LM model.

- Key assumption:
Small open economy with perfect capital mobility.

$$r = r^* \text{ (given)}$$

- Goods market equilibrium-the IS* curve:

$$Y = C(Y - T) + I(r^*) + G + NX(e)$$

Where:

e = nominal exchange rate

= foreign currency per unit of domestic currency (e.g. 110 yen per dollar)

The IS* curve: Goods Market Equilibrium

The IS* curve is drawn for a given value of r^* .

Intuition for the slope:

$$\downarrow e \Rightarrow \uparrow NX \Rightarrow \uparrow Y$$

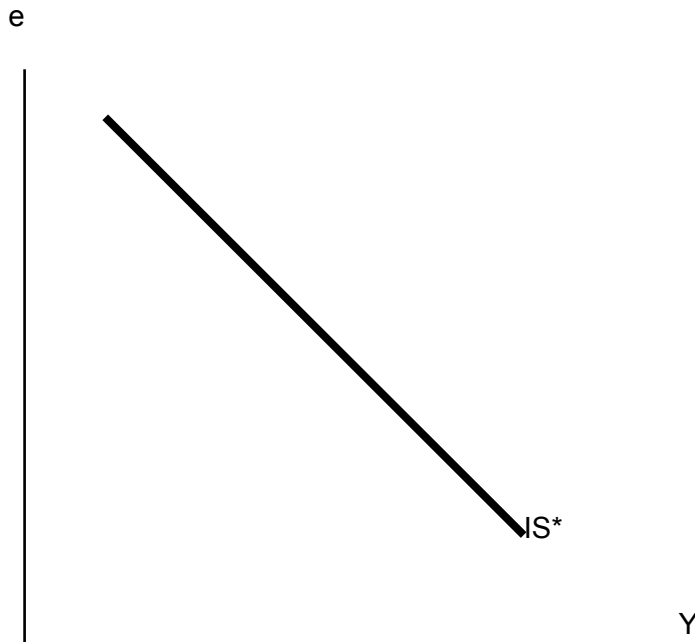

The LM* curve: Money Market Equilibrium

The LM* curve

$$M/P = L(r^*, Y)$$

- Is drawn for a given value of r^*
- Is vertical because: given r^* , there is only one value of Y that equates money demand with supply, regardless of e.

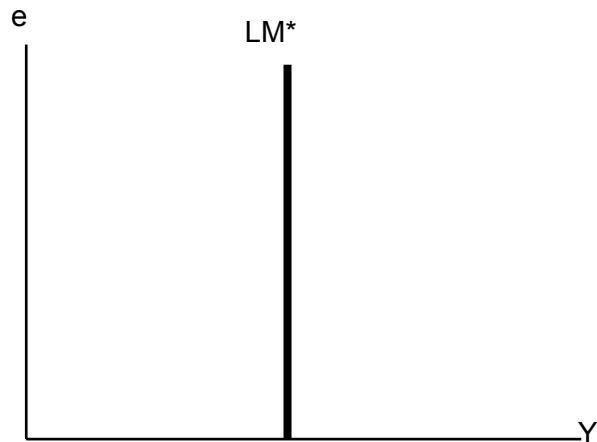

Equilibrium in the Mundell-Fleming Model

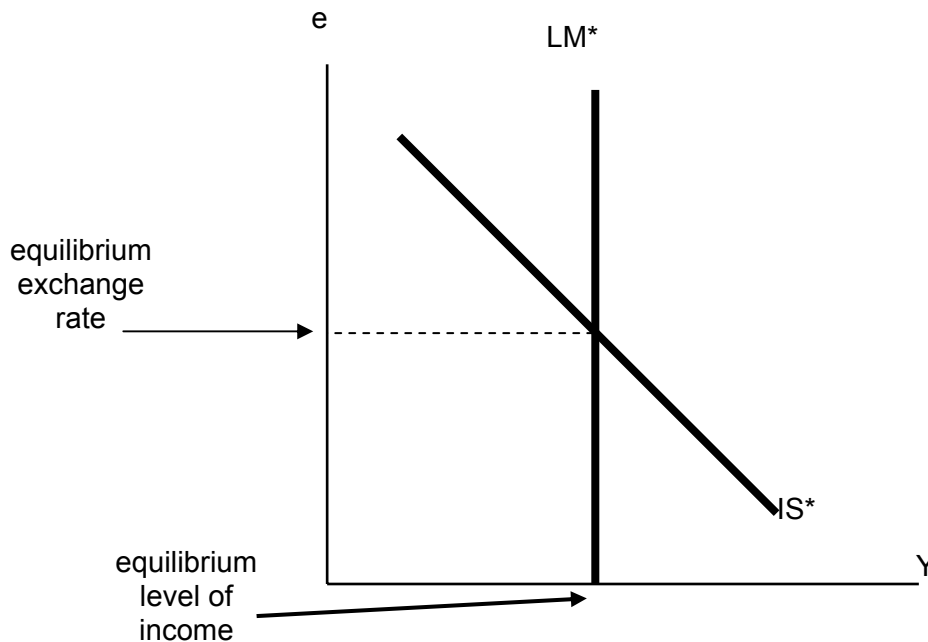

Floating & fixed exchange rates

- In a system of floating exchange rates, e is allowed to fluctuate in response to changing economic conditions.

- In contrast, under fixed exchange rates, the central bank trades domestic for foreign currency at a predetermined price.
- We now consider fiscal, monetary, and trade policy: first in a floating exchange rate system, then in a fixed exchange rate system.

Fiscal policy under floating exchange rates

$$Y = C(Y - T) + I(r^*) + G + NX(e)$$

$$M/P = L(r^*, Y)$$

At any given value of e , a fiscal expansion increases Y , shifting IS^* to the right.

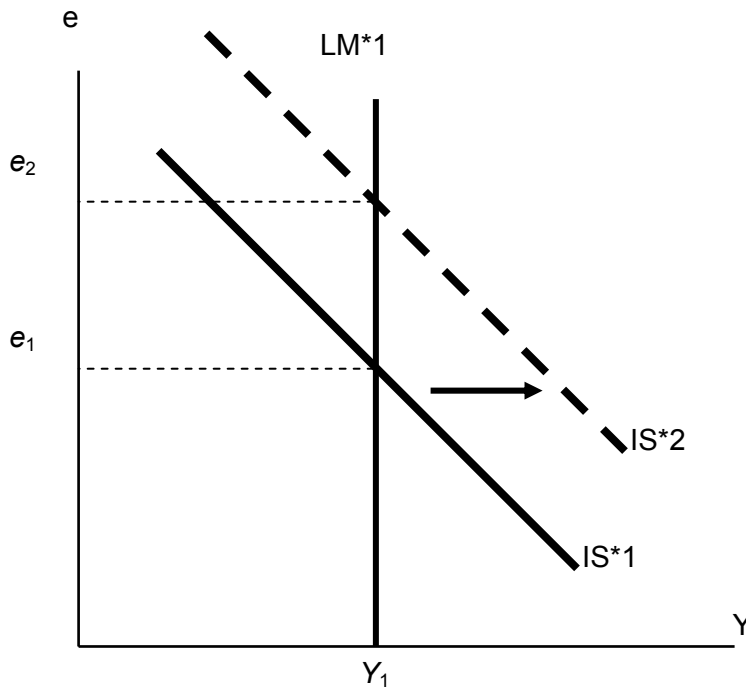

Results:

$$\Delta e > 0, \Delta Y = 0$$

Lessons about fiscal policy

- In a small open economy with perfect capital mobility, fiscal policy is utterly incapable of affecting real GDP.
- “Crowding out”
 - Closed economy: Fiscal policy crowds out investment by causing the interest rate to rise.
 - Small open economy: Fiscal policy crowds out net exports by causing the exchange rate to appreciate.

Monetary Policy under floating exchange rates

An increase in M shifts LM^* right because Y must rise to restore equilibrium in the money market.

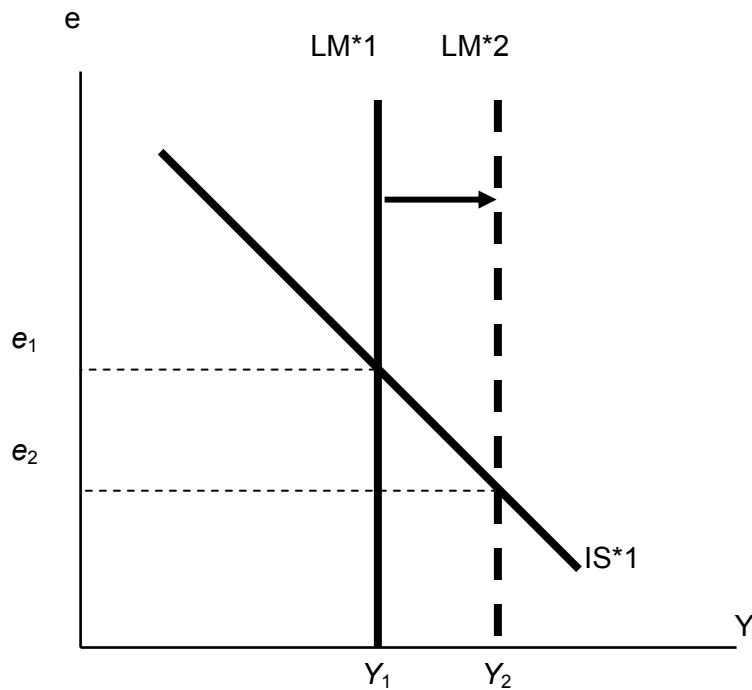

Results:

$$\Delta e < 0, \Delta Y > 0$$

Lessons about monetary policy

- Monetary policy affects output by affecting one (or more) of the components of aggregate demand:

Closed economy: $\uparrow M \Rightarrow \downarrow r \Rightarrow \uparrow I \Rightarrow \uparrow Y$

Small open economy: $\uparrow M \Rightarrow \downarrow e \Rightarrow \uparrow NX \Rightarrow \uparrow Y$

Expansionary monetary policy does not raise world aggregate demand, it shifts demand from foreign to domestic products.

Thus, the increases in income and employment at home come at the expense of losses abroad.

LESSON 31

AGGREGATE DEMAND IN THE OPEN ECONOMY(Continued...)

Equilibrium in the Mundell-Fleming model

$$Y = C(Y - T) + I(r^*) + G + NX(e)$$

$$M/P = L(r^*, Y)$$

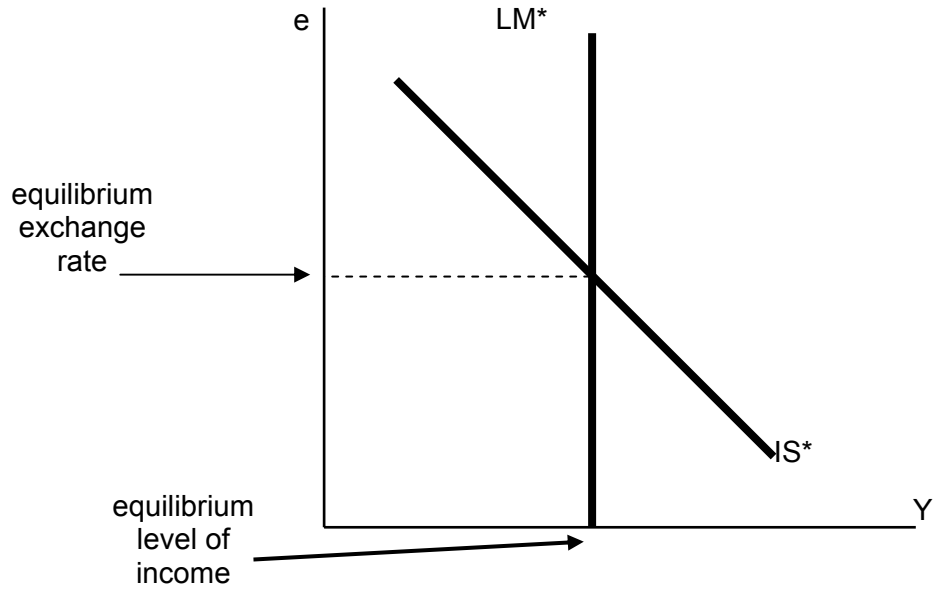

Fiscal policy under floating exchange rates

At any given value of e , a fiscal expansion increases Y , shifting IS^* to the right. Results: $\Delta e > 0$, $\Delta Y = 0$

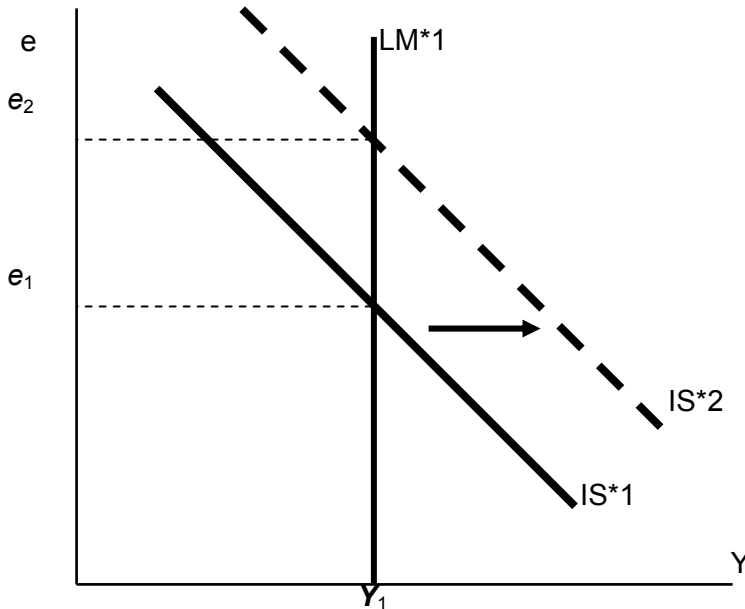

Results: $\Delta e > 0$, $\Delta Y = 0$

Monetary policy under floating exchange rates

An increase in M shifts LM* right because Y must rise to restore equilibrium in the money market.

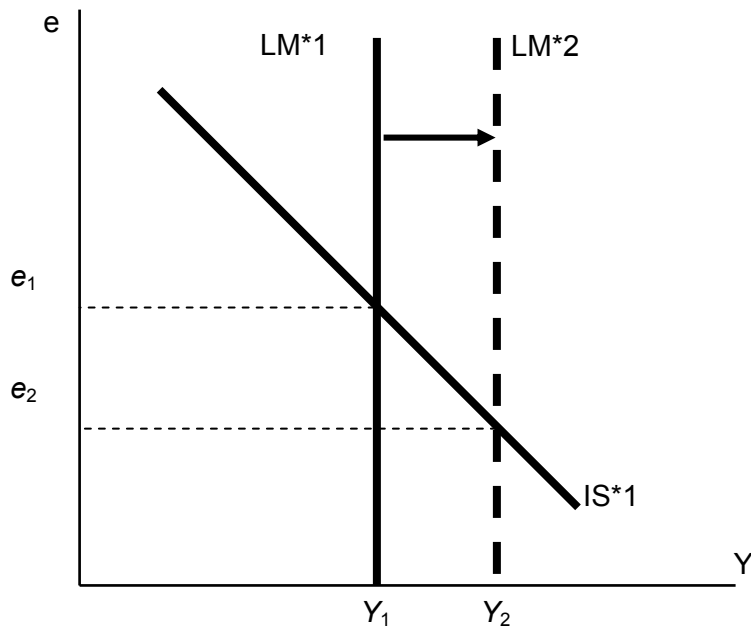

Results: $\Delta e < 0$, $\Delta Y > 0$

Trade policy under floating exchange rates

At any given value of e, a tariff or quota reduces imports, increases NX, and shifts IS* to the right.

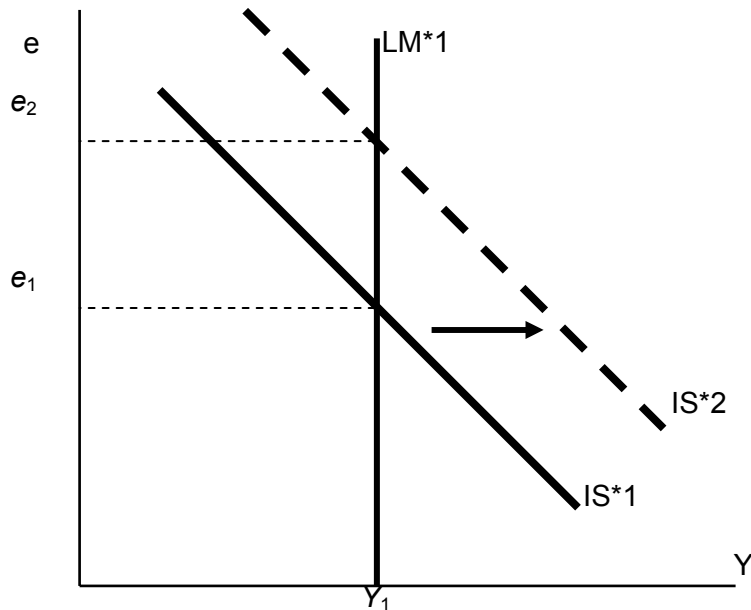

Lessons about trade policy

- Import restrictions cannot reduce a trade deficit.
- Even though NX is unchanged, there is less trade:

- The trade restriction reduces imports
 - Exchange rate appreciation reduces exports
- Less trade means fewer 'gains from trade.'

- Import restrictions on specific products save jobs in the domestic industries that produce those products, but destroy jobs in export-producing sectors. Hence, import restrictions fail to increase total employment. Worse yet, import restrictions create "sectoral shifts," which cause frictional unemployment.

Fixed exchange rates

- Under a system of fixed exchange rates, the country's central bank stands ready to buy or sell the domestic currency for foreign currency at a predetermined rate.
- In the context of the Mundell-Fleming model, the central bank shifts the LM* curve as required to keep e at its pre-announced rate.
- This system fixes the nominal exchange rate. In the long run, when prices are flexible, the real exchange rate can move even if the nominal rate is fixed.

a. The Equilibrium exchange rate is Greater than the fixed exchange rate

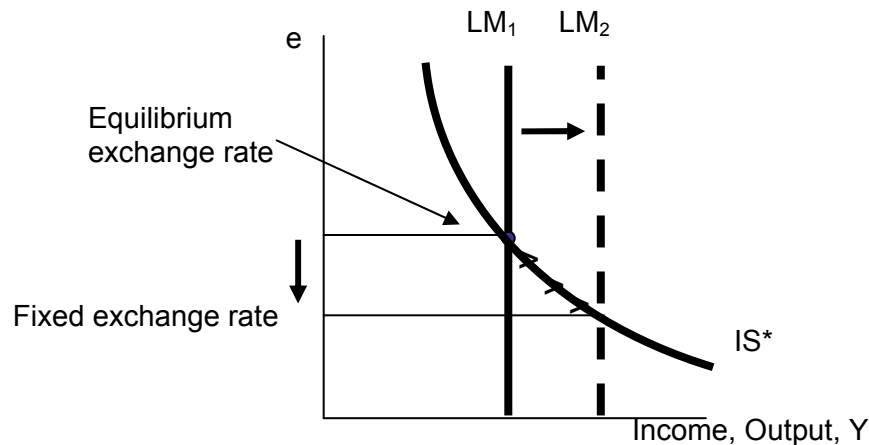

b. The Equilibrium exchange rate is less than the fixed exchange rate

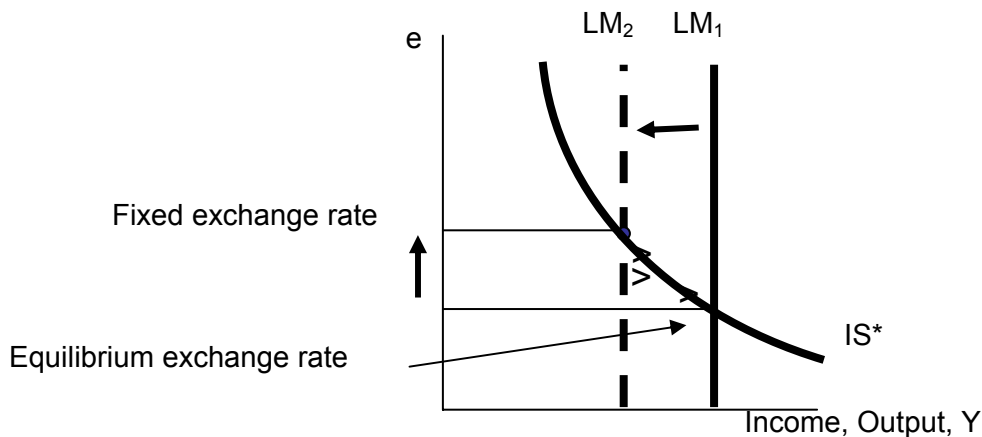

Fiscal policy under fixed exchange rates

Under fixed exchange rates, a fiscal expansion would raise e . To keep e from rising, the central bank must sell domestic currency, which increases M and shifts LM^* right.

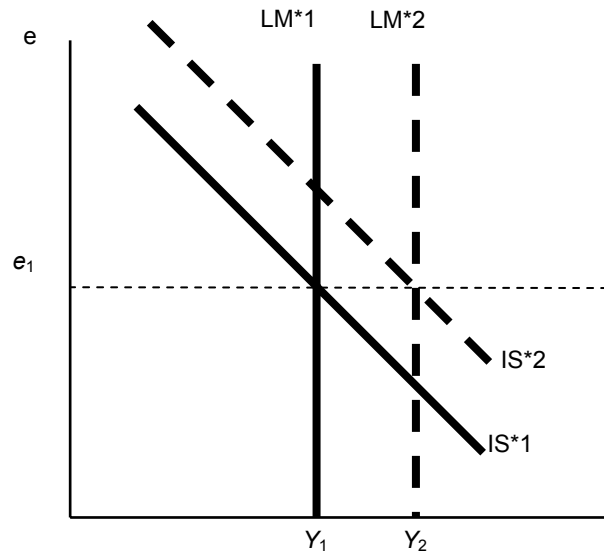

Results: $\Delta e = 0, \Delta Y > 0$

Under floating rates, fiscal policy ineffective at changing output. Under fixed rates, fiscal policy is very effective at changing output. *LM shifts out!*

Monetary policy under fixed exchange rates

An increase in M would shift LM^* right and reduce e . To prevent the fall in e , the central bank must buy domestic currency, which reduces M and shifts LM^* back left.

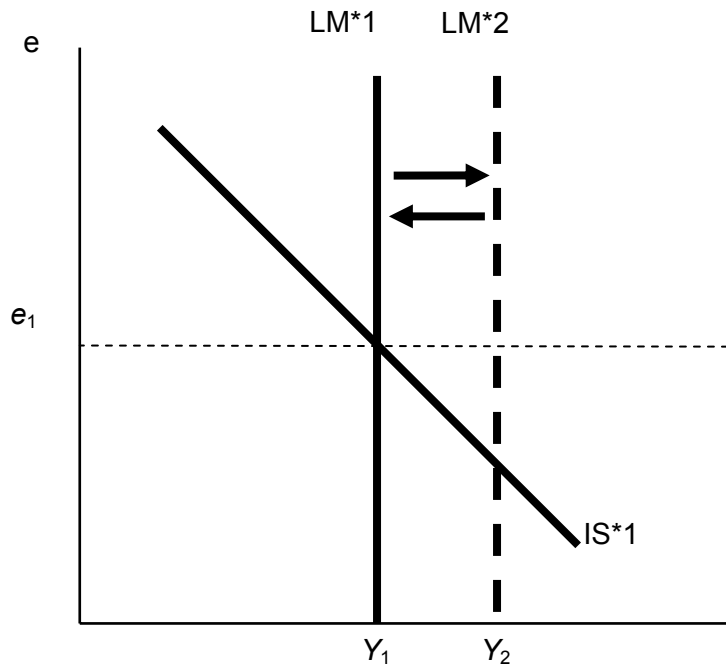

Results: $\Delta e = 0, \Delta Y = 0$

Under floating rates, monetary policy is very effective at changing output. Under fixed rates, monetary policy cannot be used to affect output.

Trade policy under fixed exchange rates

A restriction on imports puts upward pressure on e . To keep e from rising, the central bank must sell domestic currency, which increases M and shifts LM^* right.

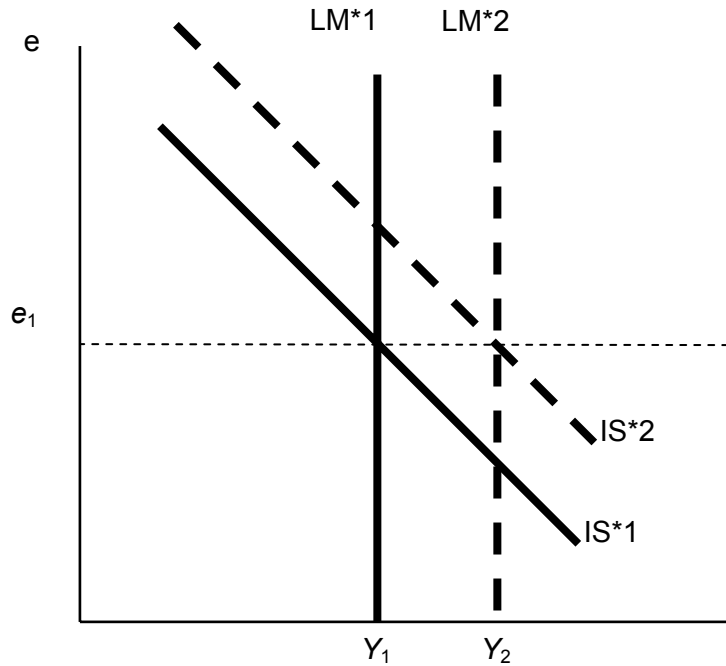

Results: $\Delta e = 0, \Delta Y > 0$

Under floating rates, import restrictions do not affect Y or NX . Under fixed rates, import restrictions increase Y and NX . But, these gains come at the expense of other countries, as the policy merely shifts demand from foreign to domestic goods

M-F: summary of policy effects

Policy	Type of Exchange Rate Regime					
	Floating			Fixed		
	Impact on					
	Y	e	NX	Y	e	NX
Fiscal Expansion	0	↑	↓	↑	0	0
Monetary Expansion	↑	↓	↑	0	0	0
Import Restriction	0	↑	0	↑	0	↑

Interest-rate differentials

Two reasons why r may differ from r^*

- Country risk:
The risk that the country's borrowers will default on their loan repayments because of political or economic turmoil. Lenders require a higher interest rate to compensate them for this risk.

- Expected exchange rate changes:
If a country's exchange rate is expected to fall, then its borrowers must pay a higher interest rate to compensate lenders for the expected currency depreciation.

Differentials in the M-F model

$$r = r^* + \theta$$

Where θ is a risk premium.

Substitute the expression for r into the IS* and LM* equations:

$$Y = C(Y - T) + I(r^* + \theta) + G + NX(e)$$

$$\frac{M}{P} = L(r^* + \theta, Y)$$

The effects of an increase in θ

IS* shifts left, because $\uparrow \theta \Rightarrow \uparrow r \Rightarrow \downarrow I$

LM* shifts right, because $\uparrow \theta \Rightarrow \uparrow r \Rightarrow \downarrow (M/P) d$,
So Y must rise to restore money market equilibrium.

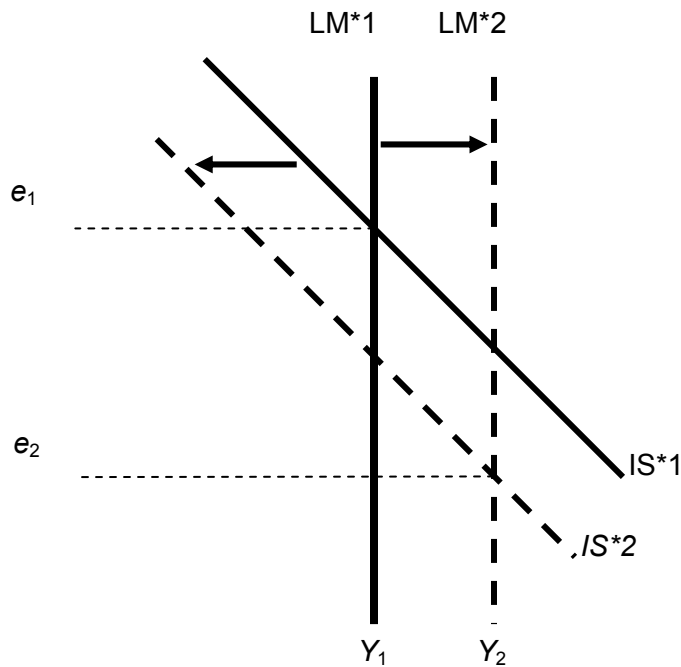

The effects of an increase in θ

- The fall in e is intuitive:
An increase in country risk or an expected depreciation makes holding the country's currency less attractive.

Note: an expected depreciation is a self-fulfilling prophecy.

- The increase in Y occurs because the boost in NX (from the depreciation) is even greater than the fall in I (from the rise in r).

LESSON 32**AGGREGATE DEMAND IN THE OPEN ECONOMY (Continued...)****Why income might not rise**

- The central bank may try to prevent the depreciation by reducing the money supply
- The depreciation might boost the price of imports enough to increase the price level (which would reduce the real money supply)
- Consumers might respond to the increased risk by holding more money.

Each of the above would shift LM* leftward.

The South East Asian Crisis

	exchange rate% change from 7/97 to 1/98	stock market % change from 7/97 to 1/98	nominal GDP% change 1997-98
Indonesia	-59.4%	-32.6%	-16.2%
Japan	-12.0%	-18.2%	-4.3%
Malaysia	-36.4%	-43.8%	-6.8%
Singapore	-15.6%	-36.0%	-0.1%
S. Korea	-47.5%	-21.9%	-7.3%
Taiwan	-14.6%	-19.7%	n.a.
Thailand	-48.3%	-25.6%	-1.2% (1996-97)
U.S.	n.a.	2.7%	2.3%

Floating vs. Fixed Exchange Rates

Argument for floating rates:

- Allows monetary policy to be used to pursue other goals (stable growth, low inflation)

Arguments for fixed rates:

- Avoids uncertainty and volatility, making international transactions easier
- Disciplines monetary policy to prevent excessive money growth & hyperinflation

Mundell-Fleming and the AD curve

- Previously, we examined the M-F model with a fixed price level. To derive the AD curve, we now consider the impact of a change in P in the M-F model.
- We now write the M-F equations as:

$$(IS^*) \quad Y = C(Y - T) + I(r^*) + G + NX(\epsilon)$$

$$(LM^*) \quad M/P = L(r^*, Y)$$

(Earlier, we could write NX as a function of e because e and ε move in the same direction when P is fixed.)

Deriving the AD curve

Why AD curve has negative slope:

- $\uparrow P \Rightarrow \downarrow (M/P)$
- $\Rightarrow LM$ shifts left
- $\Rightarrow \uparrow \varepsilon$
- $\Rightarrow \downarrow NX$
- $\Rightarrow \downarrow Y$

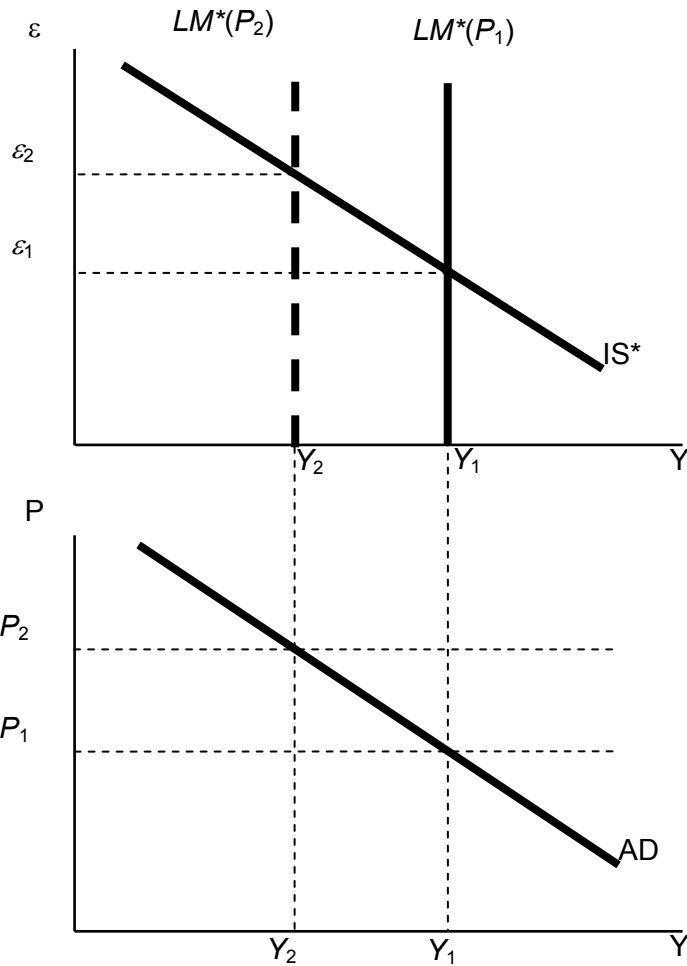

From short run to the long run

If $Y_1 < Y$ then there is downward pressure on prices. Over time, P will move down, causing

- $(M/P) \uparrow$
- $\varepsilon \downarrow$
- $NX \uparrow$
- $Y \uparrow$

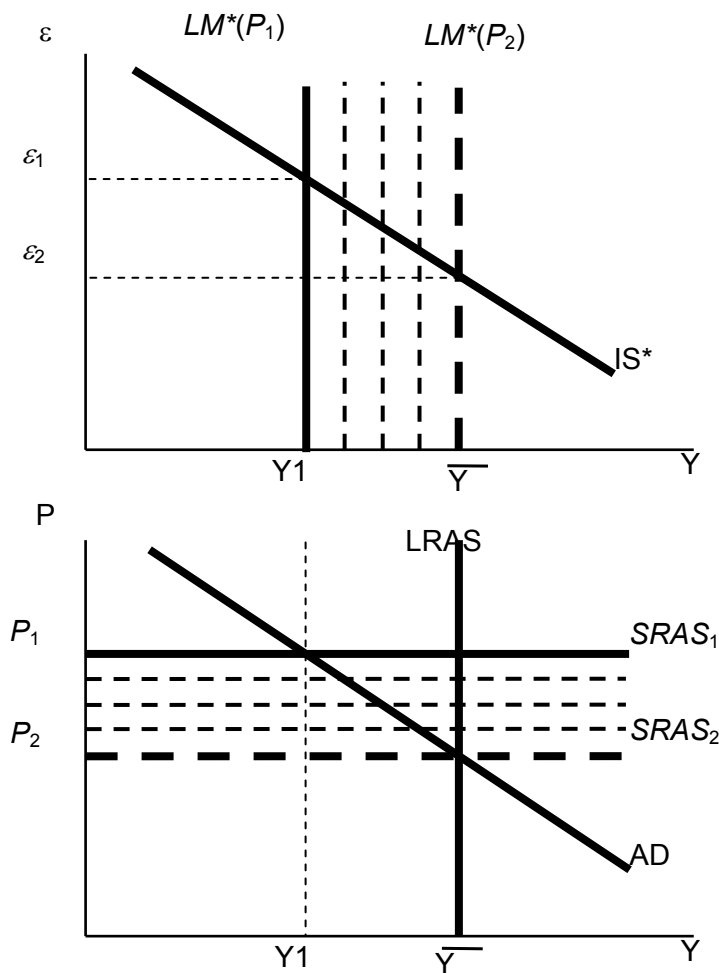

Large: between small and closed

- Many countries - including the U.S. - are neither closed nor small open economies.
- A large open economy is in between the polar cases of closed & small open.
- Consider a monetary expansion:
 - Like in a closed economy,
 $\Delta M > 0 \Rightarrow \downarrow r \Rightarrow \uparrow I$ (though not as much)
 - Like in a small open economy,
 $\Delta M > 0 \Rightarrow \downarrow \varepsilon \Rightarrow \uparrow NX$ (though not as much)

THREE MODELS OF AGGREGATE SUPPLY

- The sticky-wage model
- The imperfect-information model
- The sticky-price model

All three models imply:

$$Y = \bar{Y} + \alpha(P - P^e)$$

Where:

- Y Aggregate output
 \bar{Y} Natural rate of output
 α a positive parameter
 P the actual price level
 P^e the expected price level

The sticky-wage model

- Assumes that firms and workers negotiate contracts and fix the nominal wage before they know what the price level will turn out to be.
- The nominal wage, W , they set is the product of a target real wage, ω , and the expected price level:

$$W = \omega \times P^e$$

$$\Rightarrow \frac{W}{P} = \omega \times \frac{P^e}{P}$$

If	Then
$P = P^e$	Unemployment and output are at their natural rates
$P > P^e$	Real wage is less than its target, so firms hire more workers and output rises above its natural rate
$P < P^e$	Real wage exceeds its target, so firms hire fewer workers and output falls below its natural rate

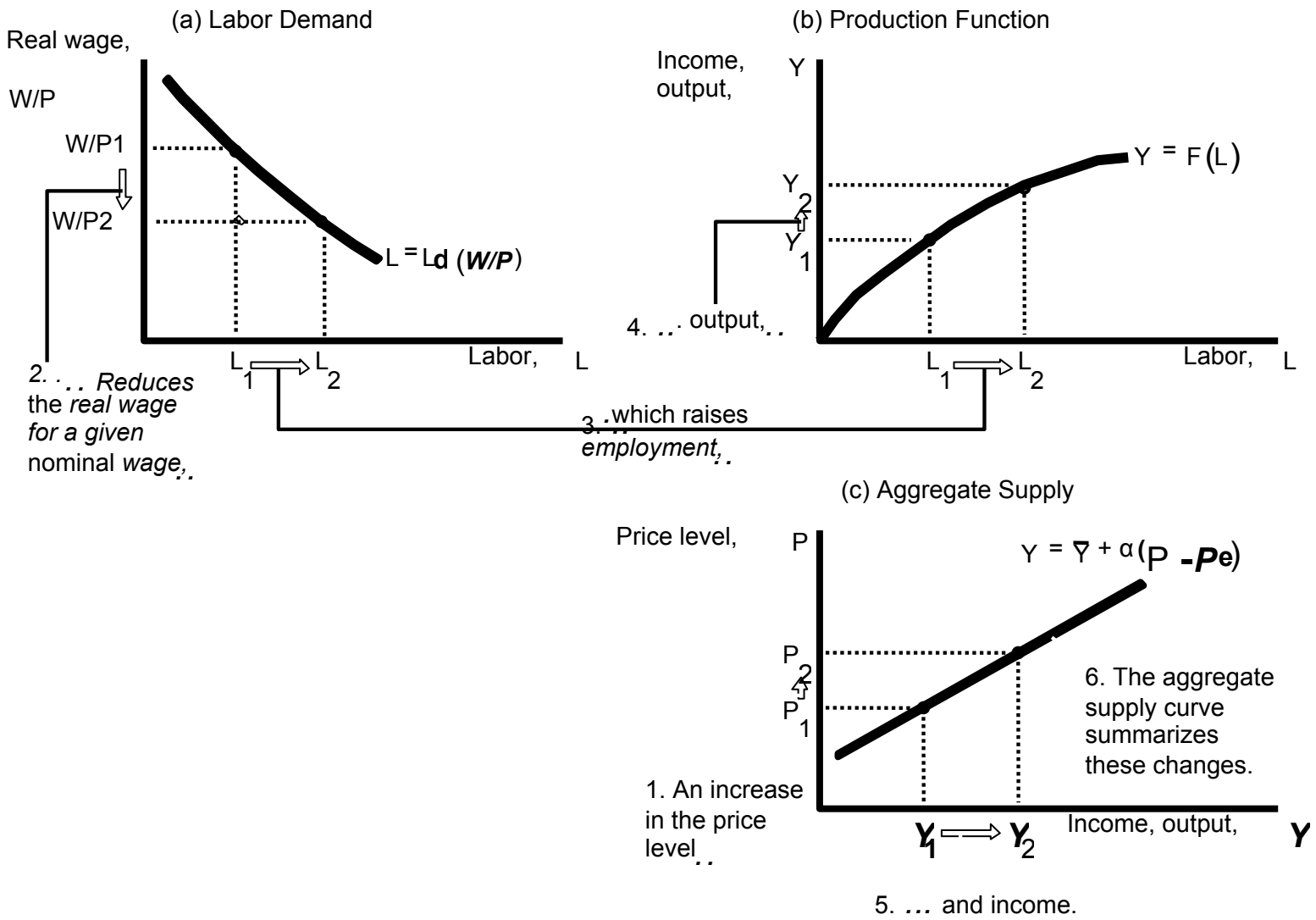

The sticky-wage model

- Implies that the real wage should be counter-cyclical, it should move in the opposite direction as output over the course of business cycles:
 - In booms, when P typically rises, the real wage should fall.
 - In recessions, when P typically falls, the real wage should rise.
- This prediction does not come true in the real world:

LESSON 33

AGGREGATE SUPPLY

The imperfect-information model

Assumptions:

- All wages and prices perfectly flexible, all markets clear
- Each supplier produces one good, consumes many goods
- Each supplier knows the nominal price of the good she produces, but does not know the overall price level
- Supply of each good depends on its relative price: the nominal price of the good divided by the overall price level. Supplier doesn't know price level at the time she makes her production decision, so uses the expected price level, P^e .
- Suppose P rises but P^e does not.

Then supplier thinks her relative price has risen, so she produces more. With many producers thinking this way, Y will rise whenever P rises above P^e .

The sticky-price model

- Reasons for sticky prices:
 - Long-term contracts between firms and customers
 - Menu costs
 - Firms do not wish to annoy customers with frequent price changes
- Assumption:
 - Firms set their own prices (e.g. as in monopolistic competition)
- An individual firm's desired price is

$$p = P + a(Y - \bar{Y})$$

Where $a > 0$.

Suppose two types of firms:

- firms with flexible prices, set prices as above
- firms with sticky prices, must set their price before they know how P and Y will turn out:

$$p = P^e + a(Y^e - \bar{Y}^e)$$

- Assume firms with sticky prices expect that output will equal its natural rate. Then,

$$p = P^e$$

- To derive the aggregate supply curve, we first find an expression for the overall price level.
- Let s denote the fraction of firms with sticky prices. Then, we can write the overall price level as

$$P = sP^e + (1-s)[P + a(Y - \bar{Y})]$$

Price set by
sticky price firm

Price set by
flexible price firm

- Subtract $(1-s)P$ from both sides:

$$sP = sP^e + (1-s)[a(Y - \bar{Y})]$$

- Divide both sides by s :

$$P = P^e + \left[\frac{(1-s)a}{s} \right] (Y - \bar{Y})$$

- High $P^e \Rightarrow$ High P
If firms expect high prices, then firms who must set prices in advance will set them high. Other firms respond by setting high prices.
- High $Y \Rightarrow$ High P
When income is high; the demand for goods is high. Firms with flexible prices set high prices. The greater the fraction of flexible price firms, the smaller is s and the bigger is the effect of ΔY on P .
- Finally, derive AS equation by solving for Y :

$$Y = \bar{Y} + \alpha(P - P^e),$$

where $\alpha = \frac{1}{(1-s)a}$

In contrast to the sticky-wage model, the sticky-price model implies a procyclical real wage: Suppose aggregate output/income falls. Then, Firms see a fall in demand for their products. Firms with sticky prices reduce production, and hence reduce their demand for labor.

- The leftward shift in labor demand causes the real wage to fall.

AGGREGATE SUPPLY (Continued...)

Three Models of Aggregate Supply

Each of the three models of aggregate supply imply the relationship summarized by the SRAS curve & equation

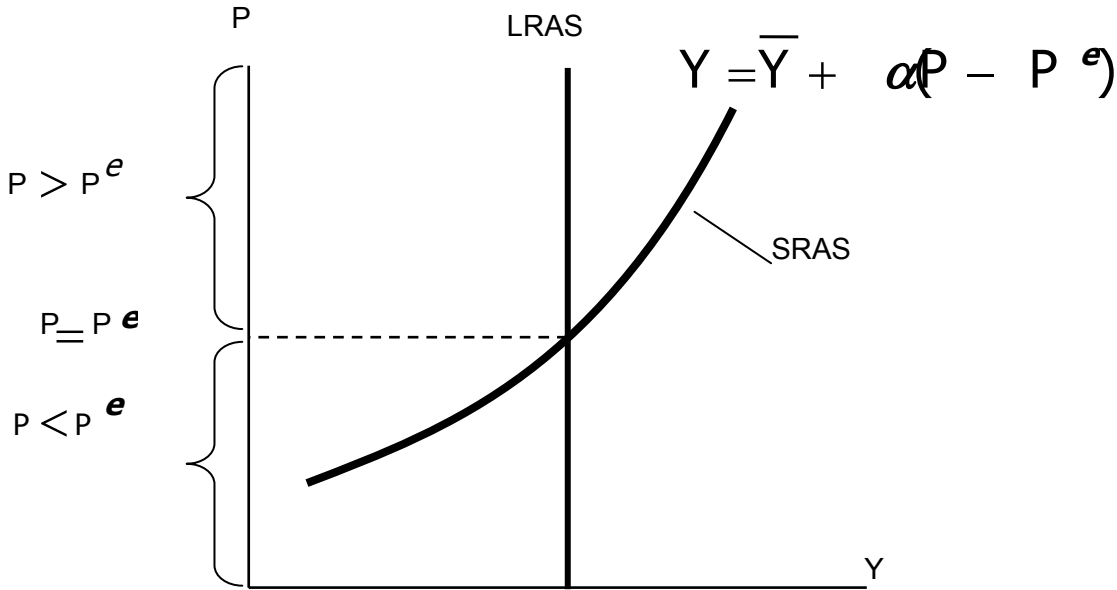

Suppose a positive AD shock moves output above its natural rate and P above the level people had expected. Over time, P^e rises, SRAS shifts up, and output returns to its natural rate.

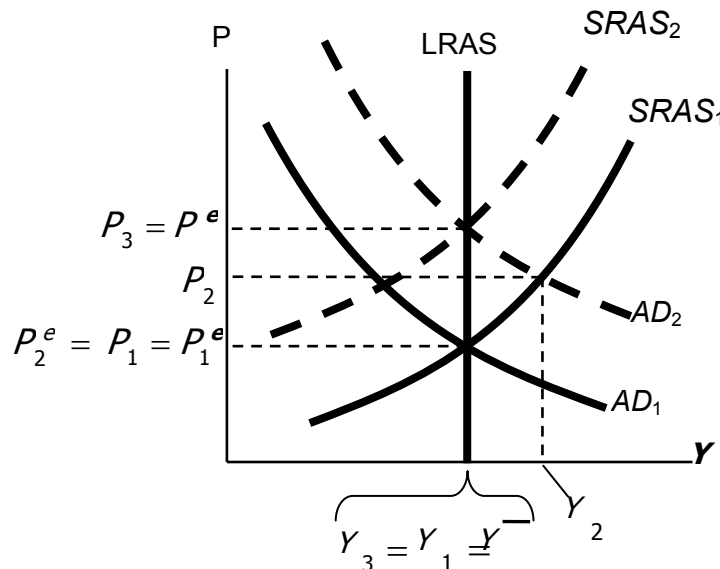

Inflation, Unemployment, and the Phillips Curve

The Phillips curve states that π depends on

- Expected inflation, π^e

- Cyclical unemployment: the deviation of the actual rate of unemployment from the natural rate
- Supply shocks, v

$$\pi = \pi^e - \beta(u - u^n) + v$$

Where $\beta > 0$ is an exogenous constant.

Deriving the Phillips Curve from SRAS

The Philips curve in its modern form states that the inflation rate depends on three forces:

- Expected inflation.
- The deviation of unemployment from the natural rate, called cyclical unemployment.
- Supply shocks.

We can drive the Philips curve from our equation for aggregate supply.

$$(1) \quad Y = \bar{Y} + \alpha(P - P^e)$$

According to aggregate supply equation:

$$(2) \quad P = P^e + (1/\alpha)(Y - \bar{Y})$$

Here are the three steps. First, add to the right-hand side of the equation a supply shock v to represent exogenous events (such as change in world's oil prices) that alter the price level and shift the short run aggregate supply curve:

$$(3) \quad P = P^e + (1/\alpha)(Y - \bar{Y}) + v$$

Next, to go from the price level to inflation rates, subtract last year's price level P_{-1} from both sides of equation to obtain

$$(4) \quad (P - P_{-1}) = (P^e - P_{-1}) + (1/\alpha)(Y - \bar{Y}) + v$$

The term on the left hand side is the difference between current price level and last years price level, which is inflation. The term on the right hand side is the difference between the expected price level and last years price level, which is expected inflation. Therefore,

$$(5) \quad \pi = \pi^e + (1/\alpha)(Y - \bar{Y}) + v$$

Now to go from output to unemployment, recall Okun's law which gives a relationship between two variables. We can write this as

$$(6) \quad (1/\alpha)(Y - \bar{Y}) = -\beta(u - u^n)$$

Using this Okun's law relationship, we can substitute left-hand side value in equation number 5, and we obtain

$$(7) \quad \pi = \pi^e - \beta(u - u^n) + v$$

The Phillips Curve and SRAS

$$\text{SRAS: } Y = \bar{Y} + \alpha(P - P^e)$$

$$\text{Phillips curve: } \pi = \pi^e - \beta(u - u^n) + v$$

- SRAS curve:
output is related to unexpected movements in the price level

- Phillips curve:
unemployment is related to unexpected movements in the inflation rate

Adaptive expectations

- Adaptive expectations: an approach that assumes people form their expectations of future inflation based on recently observed inflation.
- A simple example:
Expected inflation = last year's actual inflation

$$\pi^e = \pi_{-1}$$

- Then, the P.C. becomes

$$\pi = \pi_{-1} - \beta(u - u^n) + v$$

Inflation inertia

- In this form, the Phillips curve implies that inflation has inertia:
 - In the absence of supply shocks or cyclical unemployment, inflation will continue indefinitely at its current rate.
 - Past inflation influences expectations of current inflation, which in turn influences the wages & prices that people set.

Two causes of rising & falling inflation

- Cost-push inflation: inflation resulting from supply shocks. Adverse supply shocks typically raise production costs and induce firms to raise prices, "pushing" inflation up.
- Demand-pull inflation: inflation resulting from demand shocks. Positive shocks to aggregate demand cause unemployment to fall below its natural rate, which "pulls" the inflation rate up.

Graphing the Phillips curve

In the short run, policymakers face a trade-off between π and u .

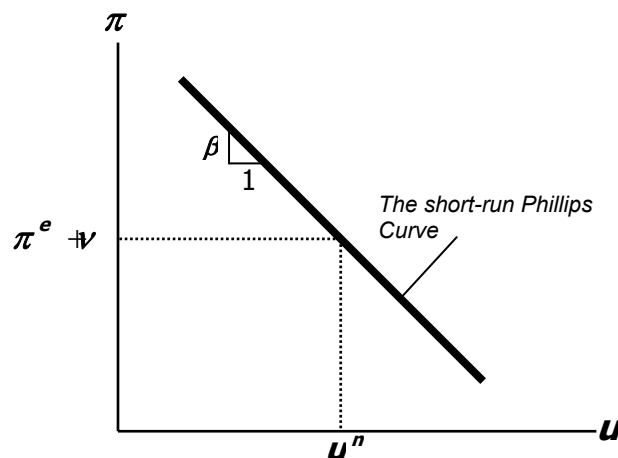

Shifting the Phillips curve

People adjust their expectations over time, so the tradeoff only holds in the short run. e.g., an increase in π^e shifts the short-run P.C. upward.

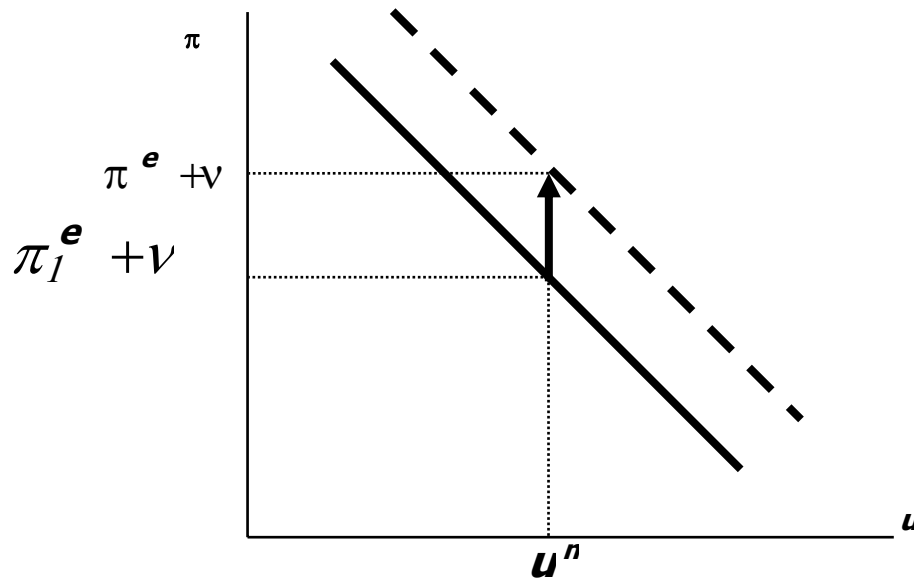

The sacrifice ratio

- To reduce inflation, policymakers can contract aggregate demand, causing unemployment to rise above the natural rate.
- The sacrifice ratio measures the percentage of a year's real GDP that must be foregone to reduce inflation by 1 percentage point.
- Estimates vary, but a typical one is 5.
- Suppose policymakers wish to reduce inflation from 6 to 2 percent. If the sacrifice ratio is 5, then reducing inflation by 4 points requires a loss of $4 \times 5 = 20$ percent of one year's GDP.
- This could be achieved several ways, e.g.
 - Reduce GDP by 20% for one year
 - Reduce GDP by 10% for each of two years
 - Reduce GDP by 5% for each of four years
- The cost of disinflation is lost GDP. One could use Okun's law to translate this cost into unemployment.

Rational expectations

Ways of modeling the formation of expectations:

- Adaptive expectations:
People base their expectations of future inflation on recently observed inflation.
- Rational expectations:
People base their expectations on all available information, including information about current and prospective future policies.

Painless disinflation?

- Proponents of rational expectations believe that the sacrifice ratio may be very small:
- Suppose $u = u^n$ and $\pi = \pi^e = 6\%$, and suppose the central bank announces that it will do whatever is necessary to reduce inflation from 6 to 2 percent as soon as possible.
- If the announcement is credible, then π^e will fall, perhaps by the full 4 points.
- Then, π can fall without an increase in u .

The natural rate hypothesis

Our analysis of the costs of disinflation, and of economic fluctuations in the preceding chapters, is based on the natural rate hypothesis:

Changes in aggregate demand affect output and employment only in the short run.

In the long run, the economy returns to the levels of output, employment, and unemployment described by the classical model

An alternative hypothesis: hysteresis

- **Hysteresis:** the long-lasting influence of history on variables such as the natural rate of unemployment.
- Negative shocks may increase u^n , so economy may not fully recover:
 - The skills of cyclically unemployed workers deteriorate while unemployed, and they cannot find a job when the recession ends.
 - Cyclically unemployed workers may lose their influence on wage-setting; insiders (employed workers) may then bargain for higher wages for themselves. Then, the cyclically unemployed “outsiders” may become structurally unemployed when the recession ends.

GOVERNMENT DEBT

Government debt and the annual budget deficit

- When a government spends more than it collects in taxes, it borrows from the private sector to finance the budget deficit.
- The **government debt** is an accumulation of all past annual deficits.

Components of Domestic Debt

- **Permanent Debt**
 - Market Loans
 - Federal Government Bonds
 - Income tax Bonds
 - National Funds Bonds
 - Federal investment Bonds
 - Prize Bonds
- **Floating Debt**
 - Treasury Bills
 - Market Treasury Bills
- **Unfunded Debts**
 - Savings or Deposit Certificates
 - Savings Account
 - Postal Life insurance
 - GP Fund

Domestic Debt Outstanding

million rupees			
	STOCK		Flow up to
	30-Jun-04	31-Jan-05	31-Jan-05
A:Permanent Debt	536,800	512,956	(23,844)
B:Floating Debt	542,943	611,648	68,704
C:Unfunded Debt	899,215	890,474	(8,741)
Total (A + B + C)	1,978,958	2,015,078	36,120

Trends in Public Debt

	Rs. Billions						
End June	1990	1995	2000	2001	2002	2003	2004
Debt payable in Rs	373.6	789.7	1575.9	1728.0	1715.2	1853.7	1921.4
<i>% of GDP</i>	42.8	42.3	41.5	41.5	39.1	38.4	35.2
Debt payable in Forex	427.6	872.5	1670.4	2025.8	1984.1	1891.3	1927.1
<i>% of GDP</i>	48.9	46.8	44.0	48.6	45.1	39.2	35.3
Total Public Debt	801.2	1662.2	3246.4	3753.8	3699.3	3745.0	3848.5
Grants			33.4	40.5	83.1	114.2	42.6
Net Public Debt	801.2	1662.2	3213.0	3713.3	3616.2	3630.8	3805.9
<i>% of GDP</i>	91.7	89.1	84.7	89.2	82.2	75.3	69.7

Source: Debt office, Ministry of Finance

Budget Deficit of Pakistan
(as percentage of GDP)

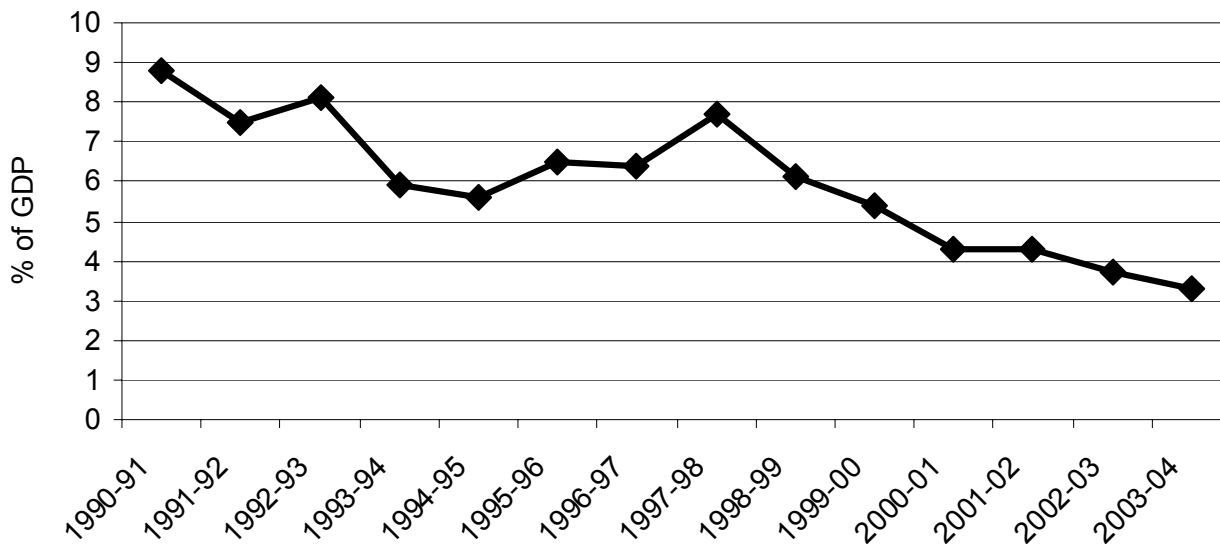

Problems in Measurement

$$\text{Govt. Budget Deficit} = \text{Govt. Spending} - \text{Govt. Revenue}$$

$$= \text{Amount of new debt}$$

- A meaningful deficit...
 - Modifies the real value of outstanding public debt to reflect current inflation.
 - Subtracts govt. assets from govt. debt.
 - Includes hidden liabilities that currently escape detection in the accounting system.
 - Calculates a cyclically-adjusted budget deficit

- A budget procedure that accounts for assets as well liabilities is called capital budgeting, because it takes into account the changes in capital.
- For Example
 - The government sells some of its land or buildings and uses the proceeds to reduce the budget deficit
 - Under current budget procedure, the reported deficit would be lower
 - Under capital budgeting, reduction in debt would be offset by a reduction in assets
 - Similarly, government borrowings to finance purchase of capital assets would not raise budget deficit
- Problem with capital Budgeting
 - It is hard to decide which government expenditures should count as capital expenditures.

Uncounted Liabilities

- Measuring budget deficit may be misleading because it excludes some govt. liabilities.
 - Pension of Govt. workers
 - Social security system
- Although social security liabilities can be differentiated from government debt, yet the government can always choose not to repay all of its debt.

The Business Cycle

- Changes occur automatically in response to a fluctuating economy.
- Example: Recession
 - \downarrow Incomes \Rightarrow \downarrow Personal Taxes
 - \downarrow Profits \Rightarrow \downarrow Corporate Taxes
 - \uparrow Number of needy persons \Rightarrow \uparrow G
Budget Deficit Increases
- These automatic changes are not errors in measurement since government truly borrows in such situations.
- But this makes it difficult to use deficit to monitor changes in fiscal policy. i.e the deficit can either fall or rise either because
 - Government has changed its policy or
 - Economy has changed direction
- Cyclically adjusted (full employment) budget deficit reflects policy changes but not the current stage of the business cycle

GOVERNMENT DEBT (Continued...)

Traditional view of govt. debt.

How would a tax cut and budget deficit affect the economy and the economic well-being of the country?

- A tax cut stimulates consumer spending and reduces national saving. The reduction in saving raises the interest rate, which crowds out investment.
- The Solow growth model shows that lower investment leads to a lower steady-state capital stock and lower output.

Solow Growth Model

Change in capital stock = investment – depreciation

$$\Delta k = i - \delta k$$

Since $i = sf(k)$, this becomes:

$$\Delta k = sf(k) - \delta k$$

Solow Growth Model

Investment and depreciation

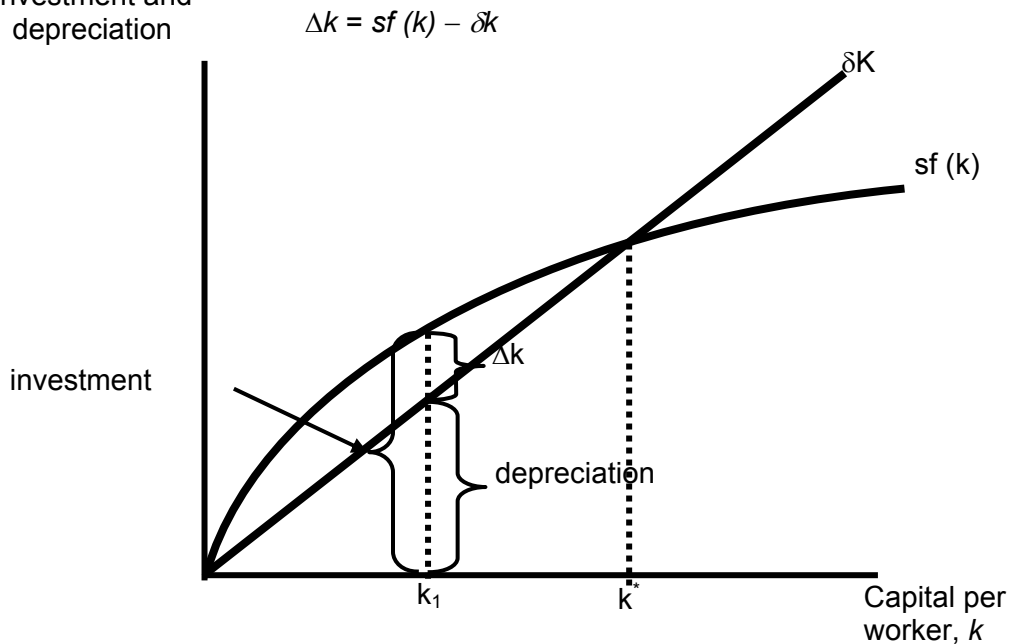

- The economy will then have less capital than the Golden Rule steady-state which will mean lower consumption and lower economic well-being.

Starting with too little capital

If $K^* < K^*_{\text{gold}}$, then increasing c^* requires an increase in s .

Future generations enjoy higher consumption, but the current one experiences an initial drop in consumption.

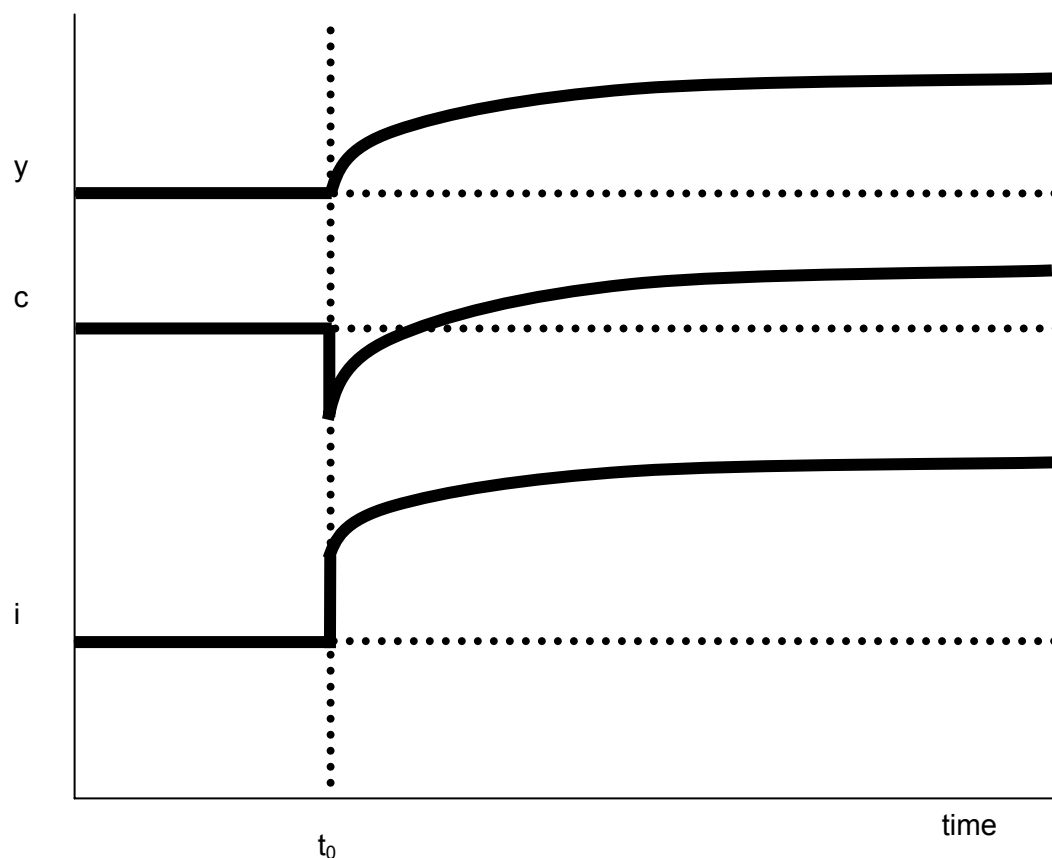

- Then we analyze the short-run impact of the policy change via the IS-LM model.

A Tax Cut

- We Have $C = C(Y - T)$

At any value of r , $\downarrow T \Rightarrow \uparrow C \Rightarrow \uparrow E \Rightarrow \uparrow Y$

...so the IS curve shifts to the right. The horizontal distance of the IS shift equals

$$\Delta Y = \text{MPC} / (1 - \text{MPC}) \Delta T$$

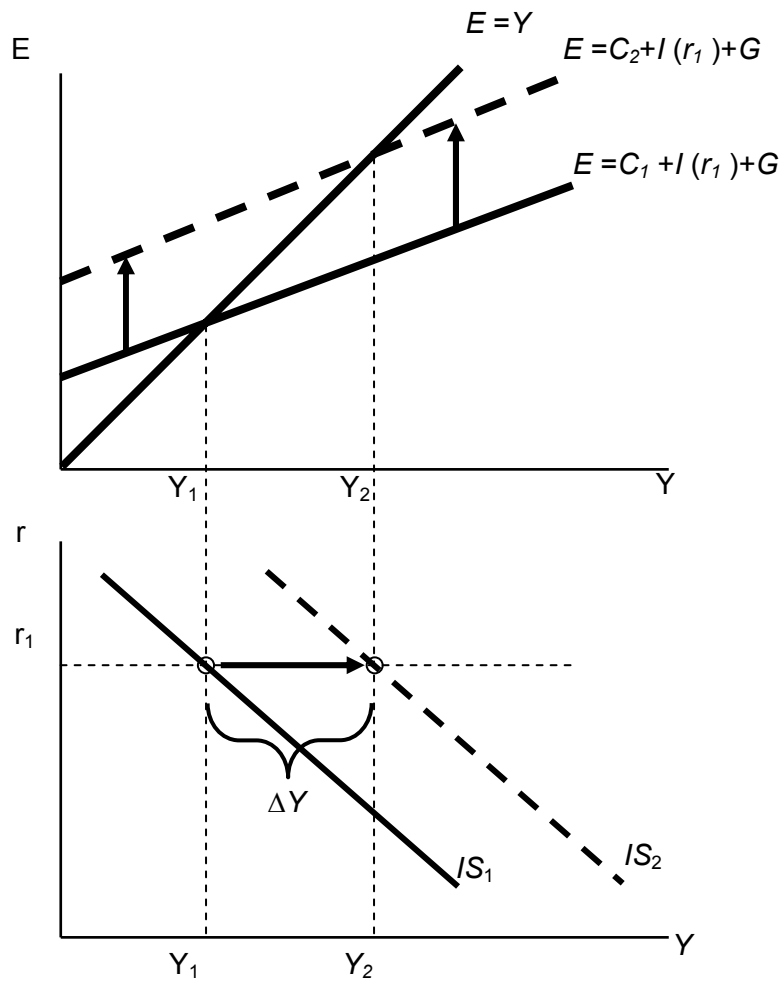

- Next, we can see how international trade affects this policy change. When national saving falls, people borrow from abroad, causing a trade deficit. It also causes the local currency to appreciate.

International Trade

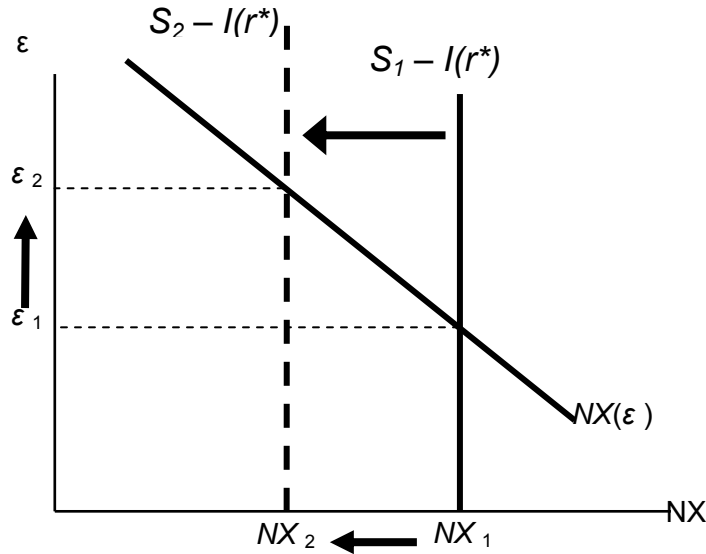

- The Mundell-Fleming model shows that the appreciation and the resulting fall in net exports reduce the short-run expansionary effect of the fiscal change.

Mundell-Fleming Model

$$Y = C(Y - T) + I(r^*) + G + NX(e)$$

$$M/P = L(r^*, Y)$$

At any given value of e , a fiscal expansion increases Y , shifting IS^* to the right. Results: $\Delta e > 0$, $\Delta Y = 0$

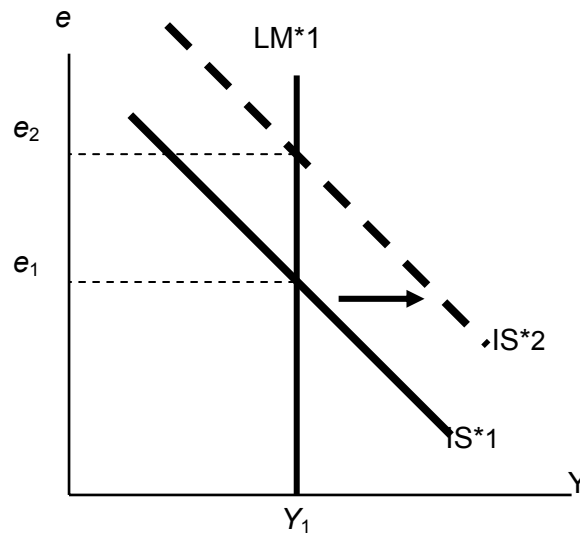

The Ricardian View of Government Debt

- Forward-looking consumers perceive that lower taxes now mean higher taxes later, leaving consumption unchanged. “Tax cuts are simply tax postponements.”
- When the government borrows to pay for its current spending (higher G), rational consumers look ahead to the future taxes required to support this debt.
- Another view
 - Govt. borrows Rs. 1,000 from a citizen to give him a Rs. 1,000 tax cut (similar to as giving him a Rs. 1,000 govt. bond as a gift)
 - On one side the government owes him Rs. 1,000 plus interest. On the other side, he owes Rs. 1,000 plus interest.
 - Overall no change in citizen’s wealth because the value of the bond is offset by the value of the future tax liability
- General Principal (Ricardian equivalence)
 - Government Debt is equivalent to future taxes
 - If consumers are forward looking, future taxes are equivalent to current taxes
 - So
 - Financing govt. by debt is equivalent to financing it by taxes.

Consumers and Future Taxes

- The essence of the Ricardian view is that when people choose their consumption, they rationally look ahead to the future taxes implied by government debt. But, how forward-looking are consumers?
- Defenders of the traditional view of government debt believe that the prospect of future taxes does not have as large an influence on current consumption as the Ricardian view assumes.

Myopia

- Ricardian view assumes that people are rational when making decisions. When the govt. borrows to pay for current spending, rational consumers look ahead to anticipate the future taxes required to support this debt.
- Traditional view is that people are myopic, meaning that they see a decrease in taxes in such a way that their current consumption increases because of this new “wealth.” They don’t see that when expansionary fiscal policy is financed through bonds, they will just have to pay more taxes in the future since bonds are just a tax-postponements.

Borrowing Constraints

- The Ricardian view assumes that consumers base their spending not only on current but on their lifetime income, which includes both current and expected future income.
- Advocates of the traditional view argue that current consumption is more important than lifetime income for those consumers who face *borrowing constraints*, which are limits on how much an individual can borrow from financial institutions.
- A person who wants to consume more than his current income must borrow. If he can’t borrow to finance his current consumption, his current income determines what he can consume, regardless of his future income. So, a debt-financed tax cut raises current income and thus consumption, even though future income is lower.
- In essence, when a government cuts current taxes and raises future taxes, it is giving tax payers a loan.

Future Generations

- According to traditional view of government debt, consumers expect the implied future taxes to fall not of them but on future generations. This behavior raises the lifetime resources of the current generation as well as their consumption.
- In essence, the debt-financed tax cut stimulates the consumption because it gives the current generation the opportunity to consume at the expense of the next generation

LESSON 37

CONSUMPTION

John Maynard Keynes and the Consumption Function

The consumption function was central to Keynes' theory of economic fluctuations presented in *The General Theory* in 1936.

- Keynes conjectured that the **marginal propensity to consume**-- the amount consumed out of an additional dollar of income-- is between zero and one. He claimed that the fundamental law is that out of every dollar of earned income, people will consume part of it and save the rest.
- Keynes also proposed the **average propensity to consume**-- the ratio of consumption to income-- falls as income rises.
- Keynes also held that income is the primary determinant of consumption and that the interest rate does not have an important role.

The Consumption Function

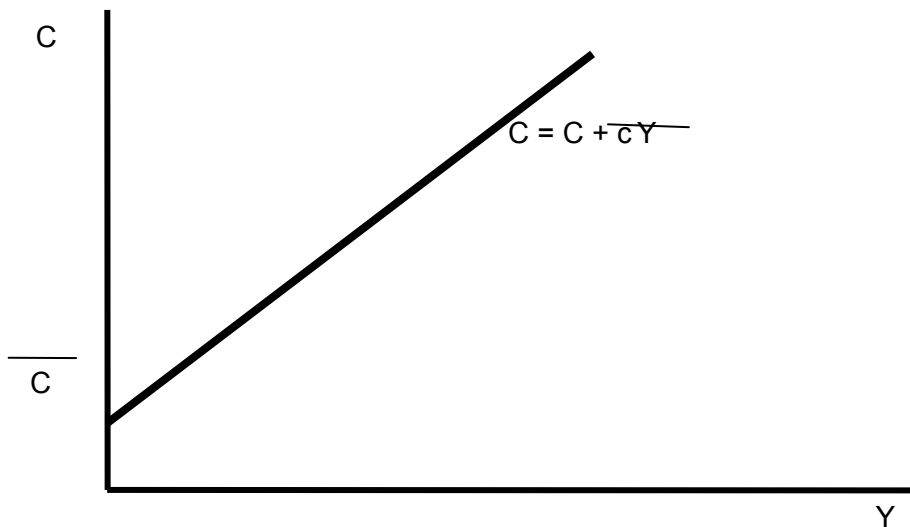
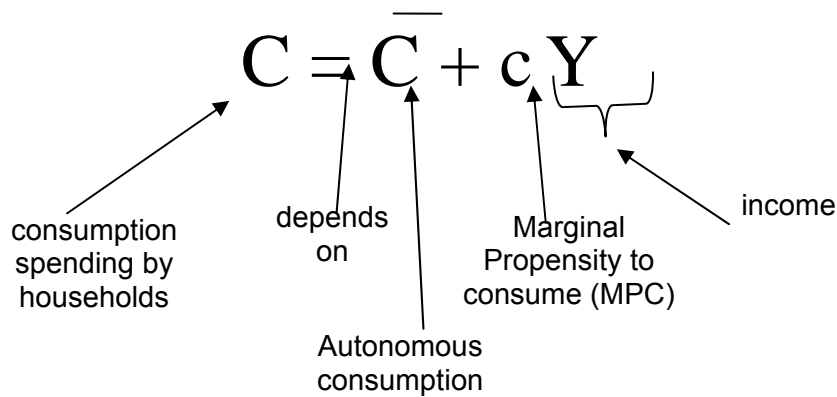

This consumption function exhibits three properties that Keynes conjectured.

1. The marginal propensity to consume c is between zero and one.
2. The average propensity to consume falls as income rises.
3. Consumption is determined by current income.

Average Propensity to Consume

$$APC = C/Y = C/\bar{Y} + c$$

As Y rises, C/Y falls, and so the average propensity to consume C/Y falls. Notice that the interest rate is not included in this function.

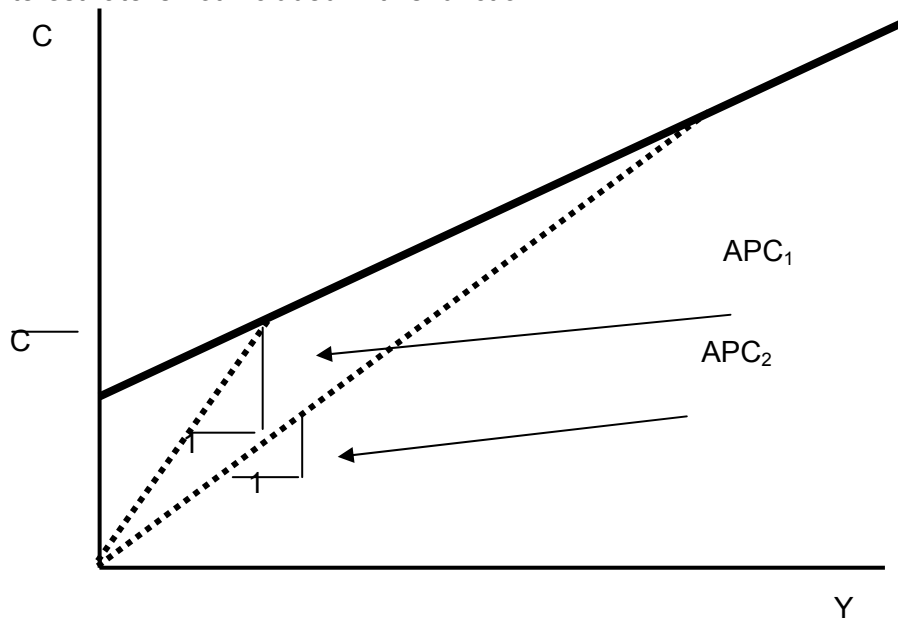

Marginal Propensity to Consume

- To understand the marginal propensity to consume (MPC), consider a shopping scenario.
 - A person who loves to shop probably has a large MPC, let's say (.99). This means that for every *extra* rupee he or she earns after tax deductions, he or she spends 99 paisas of it.
- The MPC measures the sensitivity of the change in one variable (C) with respect to a change in the other variable (Y).

Secular Stagnation and Simon Kuznets

- During World War II, on the basis of Keynes' consumption function, economists predicted that the economy would experience what they called **secular stagnation**, a long depression of infinite duration-- unless fiscal policy was used to stimulate aggregate demand.
- It turned out that the end of the war did not throw the U.S. into another depression, but it did suggest that Keynes' conjecture that the average propensity to consume would fall as income rose appeared not to hold.
- Simon Kuznets constructed new aggregate data on consumption and investment dating back to 1869 and whose work would later earn a Nobel Prize.
- He discovered that the ratio of consumption to income was stable over time, despite large increases in income; again, Keynes' conjecture was called into question.
- This brings us to the puzzle...

Consumption Puzzle

- The failure of the secular-stagnation hypothesis and the findings of Kuznets both indicated that the average propensity to consume is fairly constant over time. This presented a puzzle: why did Keynes' conjectures hold up well in the studies of household data and in the studies of short time-series, but fail when long time series were examined?

Studies of household data and short time-series found a relationship between consumption and income similar to the one Keynes conjectured-- this is called the short-run consumption function.

But, studies using long time-series found that the APC did not vary systematically with income--this relationship is called the long-run consumption function.

C

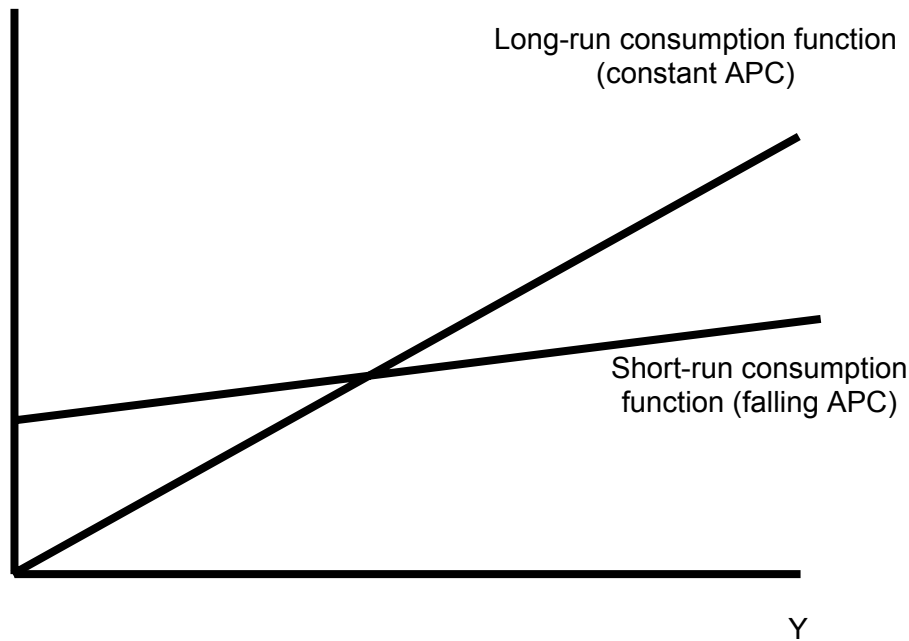

Irving Fisher and Intertemporal Choice

- The economist Irving Fisher developed the model with which economists analyze how rational, forward-looking consumers make intertemporal choices-- that is, choices involving different periods of time.
- The model illuminates
 - the constraints consumers face,
 - the preferences they have, and
 - how these constraints and preferences together determine their choices about consumption and saving.

When consumers are deciding how much to consume today versus how much to consume in the future, they face an **intertemporal budget constraint**, which measures the total resources available for consumption today and in the future.

Consumer's Budget Constraint

- Consider the decision facing a consumer who lives for two periods (representing youth & age)
- He earns Income Y_1 , Y_2 and consumes C_1 , C_2 in both periods respectively (adjusted for inflation)
- The savings in the first period will be

$$S = Y_1 - C_1$$
- In the second period

$$C_2 = (1 + r) S + Y_2$$

Where r is the real interest rate.

- Remember S can represent either saving or borrowing and the equations hold in both cases.
 - If $C_1 < Y_1$ consumer is saving $S > 0$
 - If $C_1 > Y_1$ consumer is borrowing $S < 0$
- Assume: r (borrowing) = r (saving)

Combining the two equations:

$$C_2 = (1 + r)(Y_1 - C_1) + Y_2$$

Rearranging

$$(1 + r)C_1 + C_2 = (1 + r)Y_1 + Y_2$$

- Dividing both sides by $1 + r$

$$\frac{C_2}{1+r} : Y_1 + \frac{Y_2}{1+r}$$

So we can say that

- The consumer's budget constraint implies that if the interest rate is zero, the budget constraint shows that total consumption in the two periods equals total income in the two periods. In the usual case in which the interest rate is greater than zero, future consumption and future income are discounted by a factor of $1 + r$.
- This **discounting** arises from the interest earned on savings. Because the consumer earns interest on current income that is saved, future income is worth less than current income.
- Also, because future consumption is paid for out of savings that have earned interest, future consumption costs less than current consumption.
- The factor $1/(1+r)$ is the price of second-period consumption measured in terms of first-period consumption; it is the amount of first-period consumption that the consumer must forgo to obtain 1 unit of second-period consumption.

Here are the combinations of first-period and second-period consumption the consumer can choose.

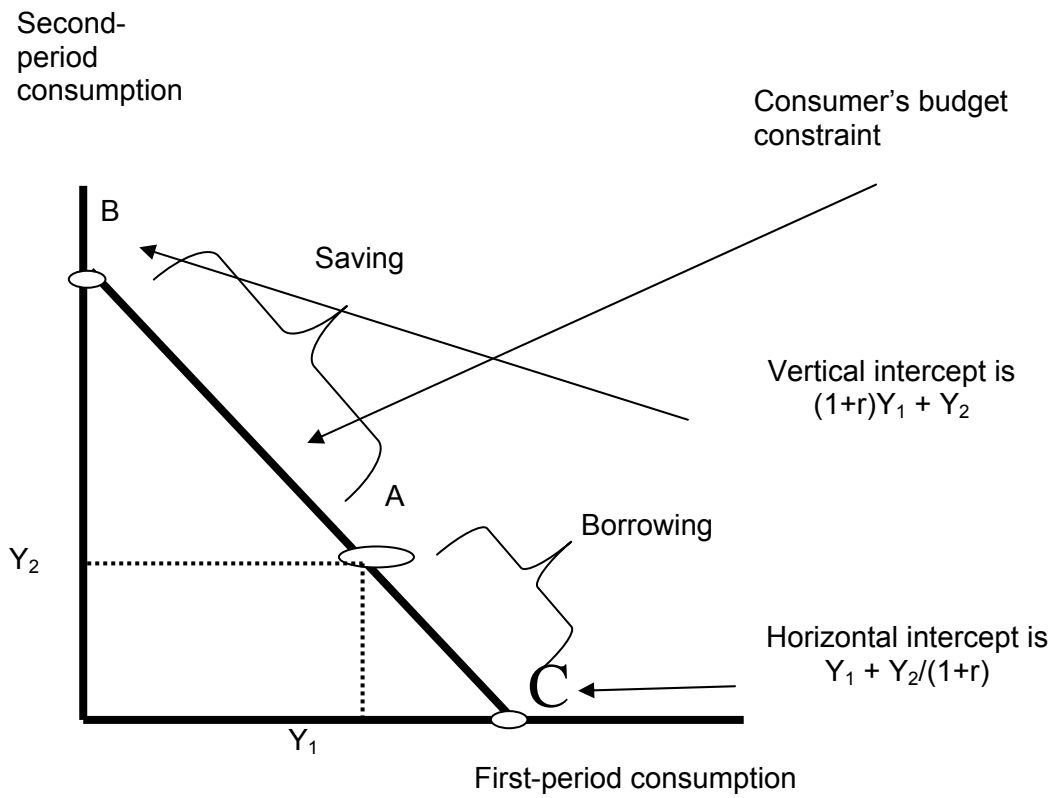

If he chooses a point between A and B, he consumes less than his income in the first period and saves the rest for the second period. If he chooses between A and C, he consumes more than his income in the first period and borrows to make up the difference.

CONSUMPTION (Continued...)

Consumer's Budget Constraint

Irving Fisher's generalization:

$$\frac{C_2}{1+r} : Y_1 + \frac{Y_2}{1+r}$$

- So we can say that
 - The consumer's budget constraint implies that if the interest rate is zero, the budget constraint shows that total consumption in the two periods equals total income in the two periods. In the usual case in which the interest rate is greater than zero, future consumption and future income are discounted by a factor of $1 + r$.
 - This **discounting** arises from the interest earned on savings. Because the consumer earns interest on current income that is saved, future income is worth less than current income.
 - Also, because future consumption is paid for out of savings that have earned interest, future consumption costs less than current consumption.
 - The factor $1/(1+r)$ is the price of second-period consumption measured in terms of first-period consumption; it is the amount of first-period consumption that the consumer must forgo to obtain 1 unit of second-period consumption.

Second-period consumption

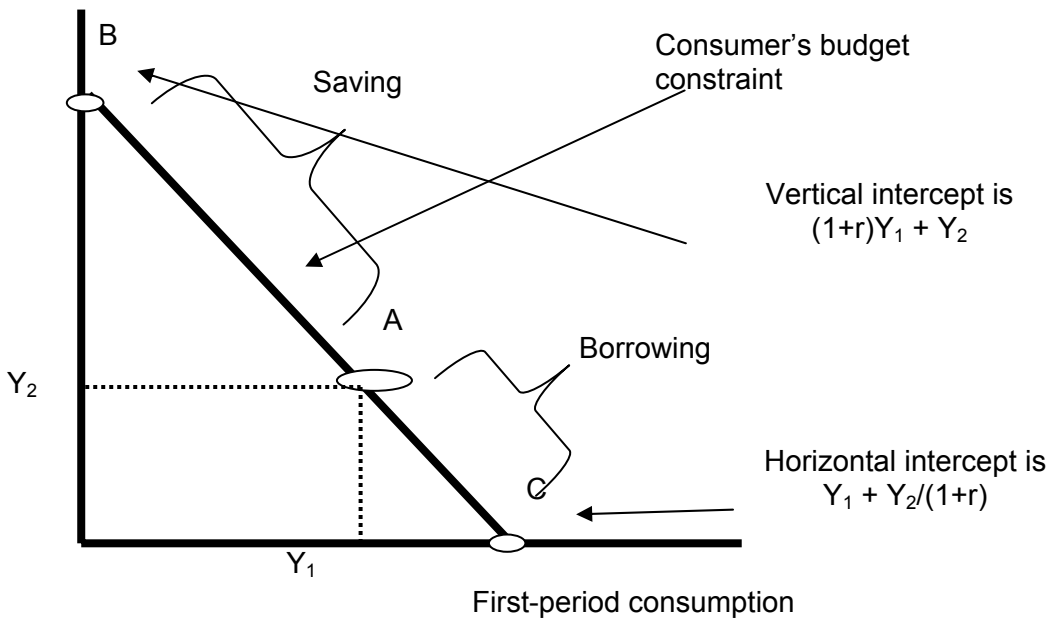

If he chooses a point between A and B, he consumes less than his income in the first period and saves the rest for the second period. If he chooses between A and C, he consumes more than his income in the first period and borrows to make up the difference.

Consumer Preferences

The consumer's preferences regarding consumption in the two periods can be represented by indifference curves.

An indifference curve shows the combination of first-period and second-period consumption that makes the consumer equally happy.

- The slope at any point on the indifference curve shows how much second-period consumption the consumer requires in order to be compensated for a 1-unit reduction in first-period consumption. This slope is the marginal rate of substitution between first-period consumption and second-period consumption. It tells us the rate at which the consumer is willing to substitute second-period consumption for first-period consumption.

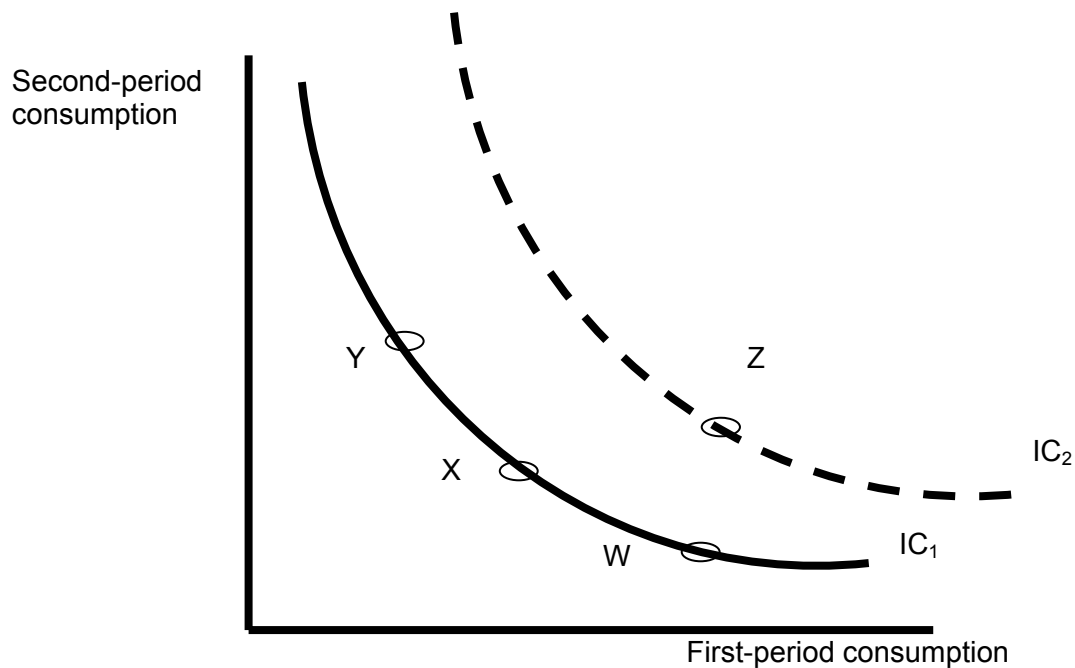

Higher indifference curves such as IC_2 are preferred to lower ones such as IC_1 . The consumer is equally happy at points W , X , and Y , but prefers Z to all the others-- Point Z is on a higher indifference curve and is therefore not equally preferred to W , X and Y .

Optimization

The consumer achieves his highest (or optimal) level of satisfaction by choosing the point on the budget constraint that is on the highest indifference curve. At the optimum, the indifference curve is tangent to the budget constraint.

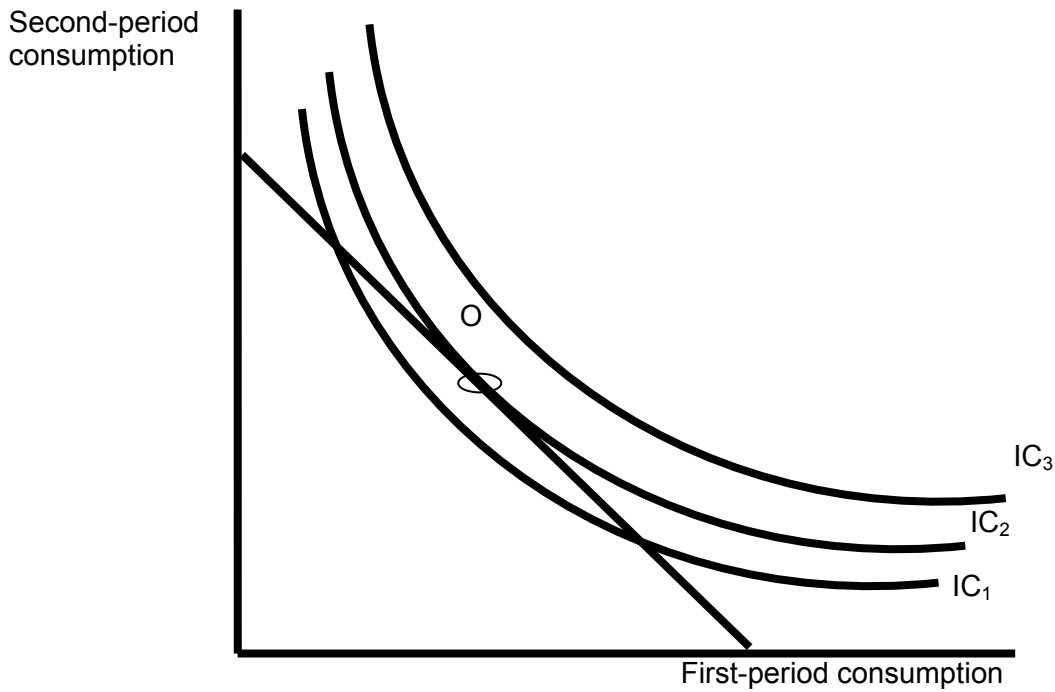

How changes in income affect consumption

An increase in either first- or second-period income shifts the budget constraint outward. If consumption in period one and consumption in period two are both **normal goods**- those that are demanded more as income rises, this increase in income raises consumption in both periods.

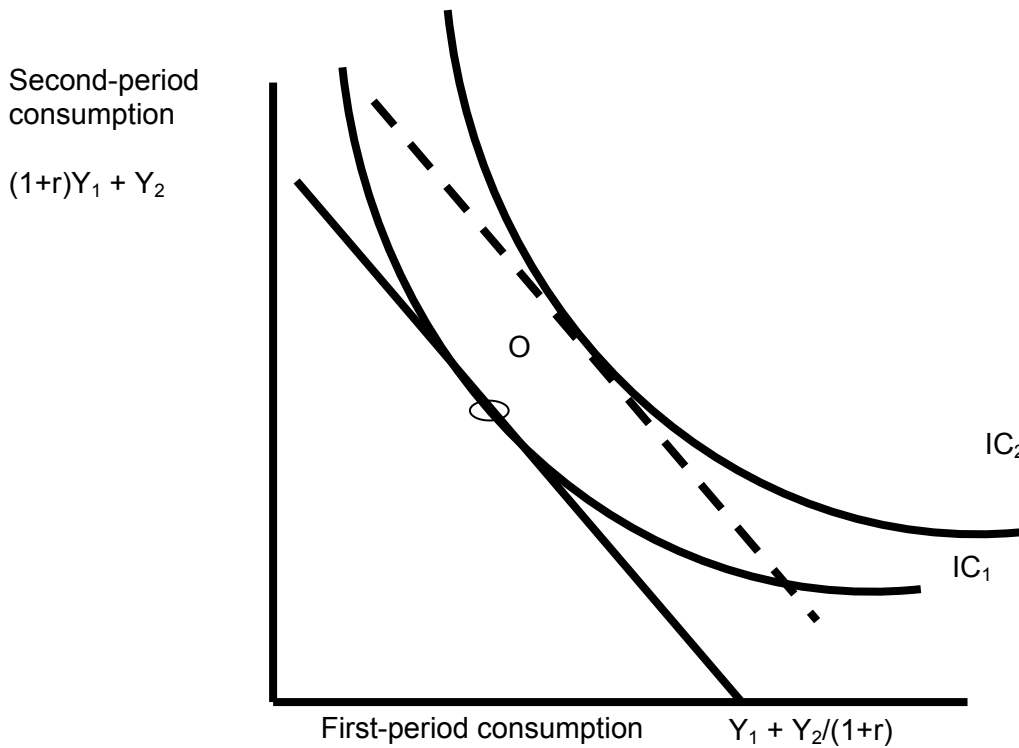

How changes in real interest rate affect consumption

- Economists decompose the impact of an increase in the real interest rate on consumption into two effects: an **income effect** and a **substitution effect**.
- The income effect is the change in consumption that results from the movement to a higher indifference curve.
- The substitution effect is the change in consumption that results from the change in the relative price of consumption in the two periods.

Second- period consumption

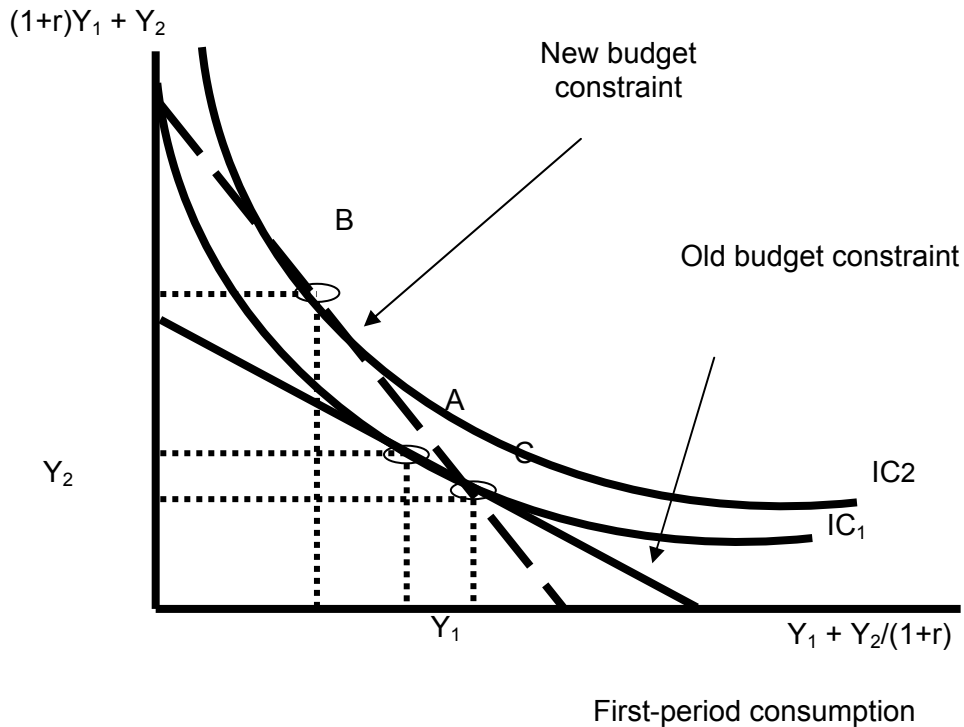

An increase in the interest rate rotates the budget constraint around the point C, where C is (Y_1, Y_2) . The higher interest rate reduces first period consumption (move to point A) and raises second-period consumption (move to point B).

- Irving Fisher’s Model shows that depending on the consumer preferences, changes in real interest rate could either raise or lower consumption.
- So, economic theory alone cannot predict how interest rate influences consumption. Therefore economists have studied the empirics of interest rate affecting the consumption and saving.

Savings and the Real Interest Rate

- Data shows that there’s no apparent relationship between the two variables. Or, savings does not depend on interest rate.
- Economists claim that income and substitution effects of higher interest rates approximately cancel each other.

Constraints on Borrowings

- The inability to borrow prevents current consumption from exceeding current income. A constraint on borrowing can therefore be expressed as $C_1 \leq Y_1$.

- This inequality states that consumption in period one must be less than or equal to income in period one. This additional constraint on the consumer is called a borrowing constraint, or sometimes, a liquidity constraint.
- The analysis of borrowing leads us to conclude that there are two consumption functions. For some consumers, the borrowing constraint is not binding, and consumption in both periods depends on the present value of lifetime income.
- For other consumers, the borrowing constraint binds. Hence, for those consumers who would like to borrow but cannot, consumption depends only on current income.
- If the consumer cannot borrow, he faces the additional constraint that 1st period consumption cannot exceed 1st period income.

2nd period consumption,
C2

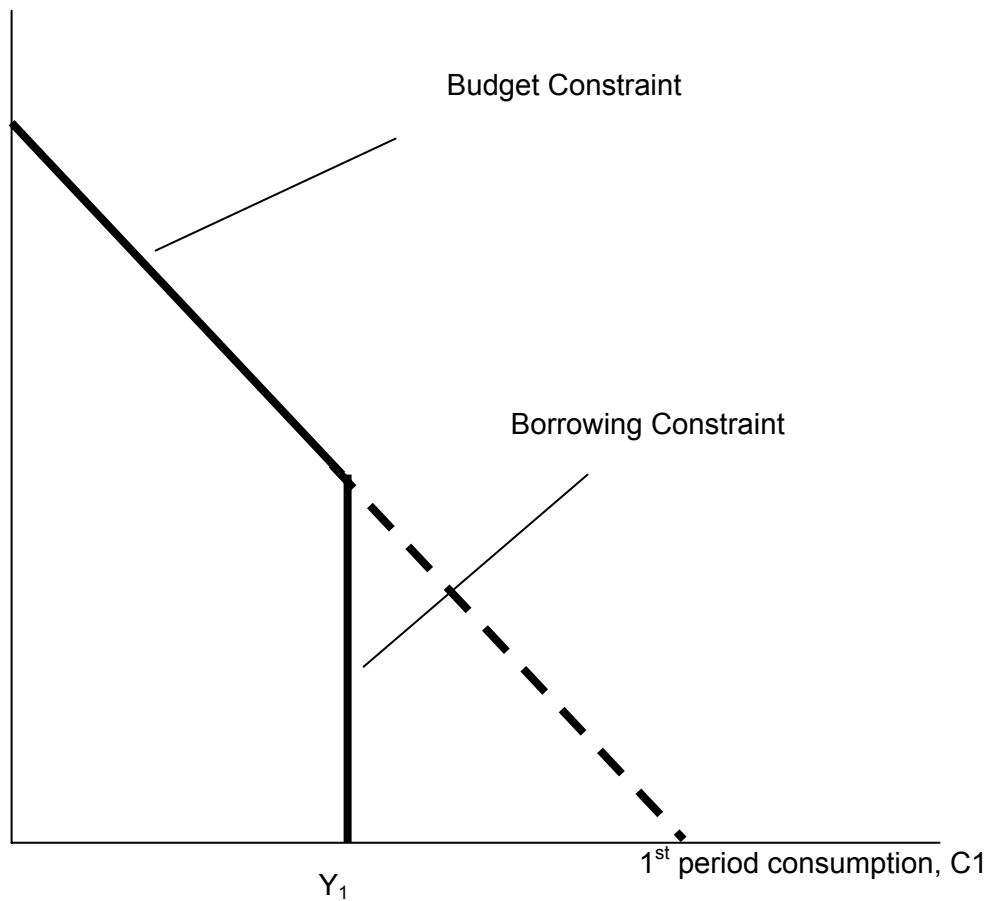

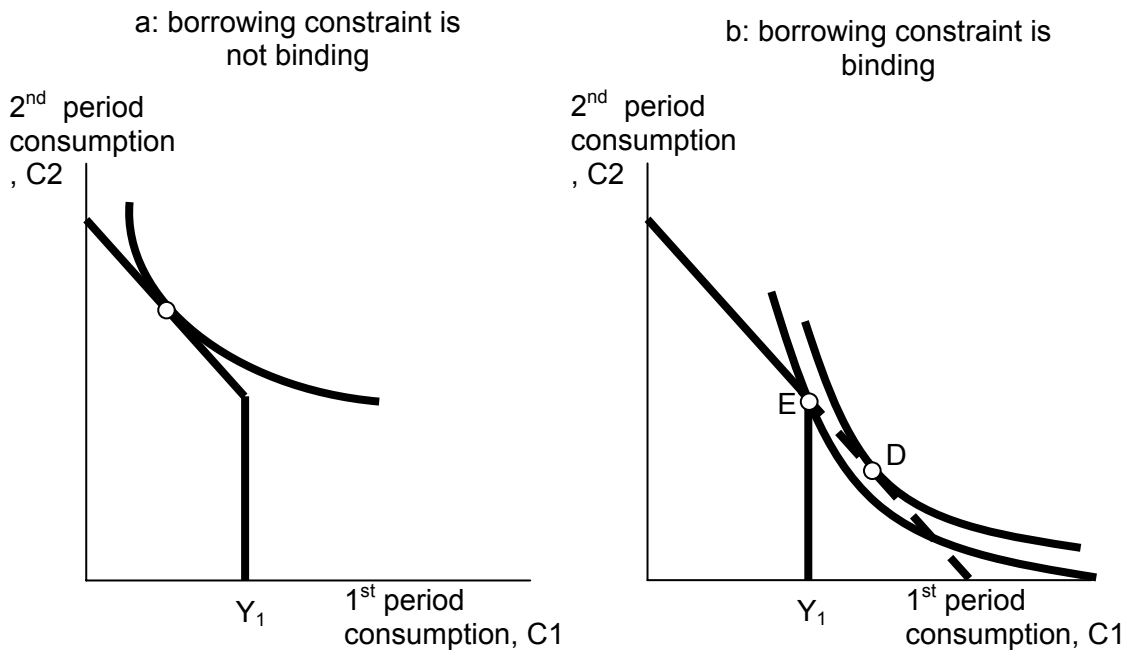

High Japanese Savings Rate

- Japan has one of the world’s highest savings rate.
- On one hand, many economists believe that this is a key to the rapid growth Japan experienced in the decades after World War II, The Solow growth model also shows that saving rate is a primary determinant of a country’s steady state level of income.

An increase in the saving rate raises investment causing the capital stock to grow toward a new steady state

Investment and depreciation

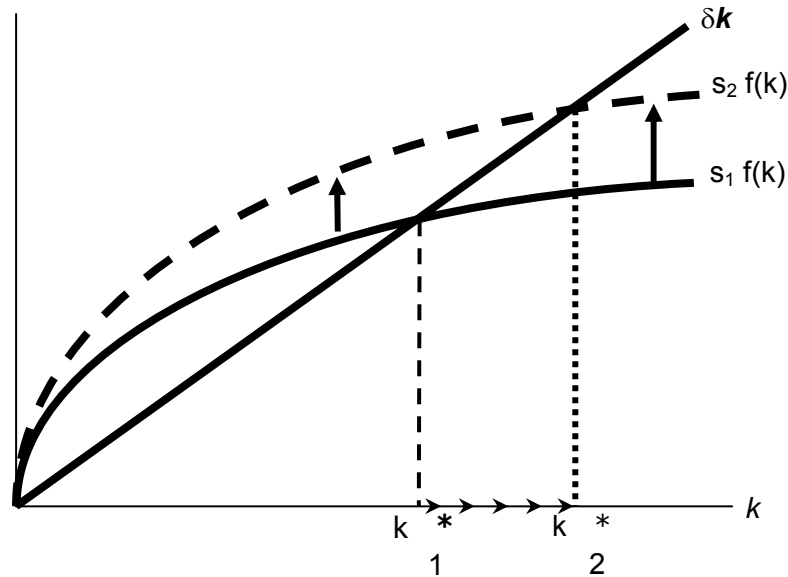

- On the other hand, some economists say that high savings rate has contributed to Japan’s slump during 1990s. High savings means lower consumption which according to IS-LM model translates into low aggregate demand and reduced income.
- Why Do Japanese consume so less or save so much?
 - It is harder for households to borrow in Japan

- In case of borrowing to purchase a house (the most common cause of borrowing), down payment rates are very high (up to 40%)
- Japanese Tax system encourages saving by taxing capital income very lightly
- Japanese are more risk averse and patient.

CONSUMPTION (Continued...)

John Maynard Keynes and the Consumption Function

The consumption function exhibits three properties that Keynes conjectured.

1. The marginal propensity to consume c is between zero and one.
2. The average propensity to consume falls as income rises.
3. Consumption is determined by current income.

Simon Kuznets and the Consumption Puzzle

- The failure of the secular-stagnation hypothesis and the findings of Kuznets both indicated that the average propensity to consume is fairly constant over time.
- This presented a puzzle: why did Keynes' conjectures hold up well in the studies of household data and in the studies of short time-series, but fail when long time series were examined?

Irving Fisher and Intertemporal Choice

- The economist Irving Fisher developed the model with which economists analyze how rational, forward-looking consumers make intertemporal choices-- that is, choices involving different periods of time.
- The model illuminates
 - the constraints consumers face,
 - the preferences they have, and
 - how these constraints and preferences together determine their choices about consumption and saving.

When consumers are deciding how much to consume today versus how much to consume in the future, they face an **intertemporal budget constraint**, which measures the total resources available for consumption today and in the future. The generalization is:

$$\frac{C_2}{1+r} : Y_1 + \frac{Y_2}{1+r}$$

Franco Modigliani and the life-cycle Hypothesis

In the 1950's, Franco Modigliani, Ando and Brumberg used Fisher's model of consumer behavior to study the consumption function. One of their goals was to study the consumption puzzle. According to Fisher's model, consumption depends on a person's lifetime income. Modigliani emphasized that income varies systematically over people's lives and that saving allows consumers to move income from those times in life when income is high to those times when income is low. This interpretation of consumer behavior formed the basis of his **life-cycle hypothesis**.

The Hypothesis

- Most people plan to stop working at about age 65, and they expect their incomes to fall when they retire, but don't want a drop in standard of living characterized by consumption.
- Suppose a consumer expects to live another T years, has wealth of W and expects to earn income Y until she retires R years from now.
 - What level of consumption will the consumer choose to have a smooth consumption over her life?

The Life-cycle Consumption Function

- The Lifetime resources of consumer for T years are wealth W and lifetime earnings of R x Y (assuming interest rate to be zero).
- To have smoothest consumption over lifetime, she divides such that

$$C = (W + RY) / T \quad \text{or}$$

$$C = (1 / T)W + (R / T)Y$$

- If she expects T = 50 and R = 30, then the consumption function will be

$$C = 1 / 50W + 30/50Y \text{ or}$$

$$C = 0.02W + 0.6Y$$

- Generalizing for Aggregate Consumption function of the economy:

$$C = \alpha W + \beta Y$$

Where, α = MPC out of Wealth

β = MPC out of Income

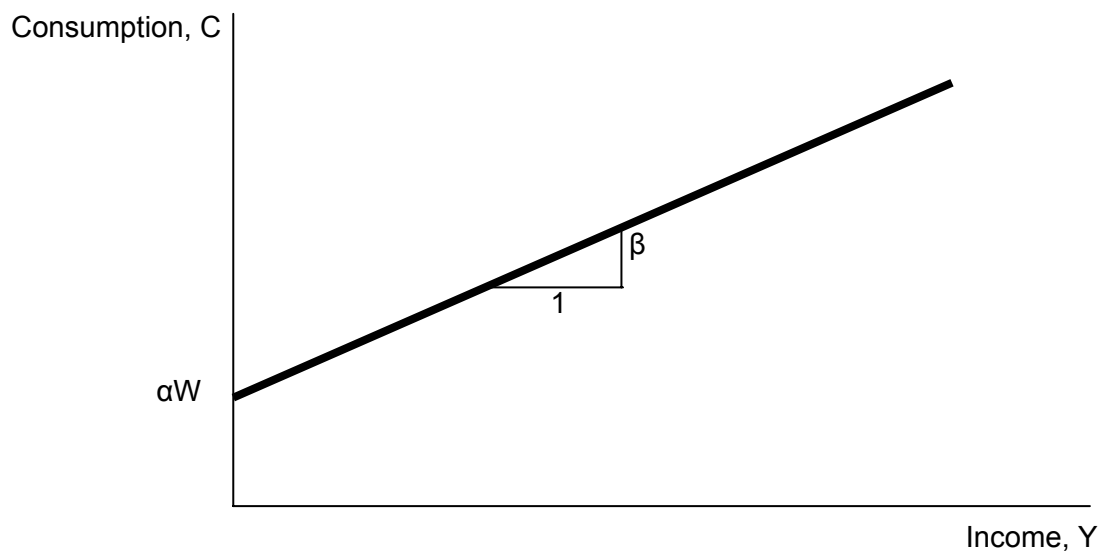

Solving the Consumption Puzzle

- According to Life-cycle consumption function,

$$APC = C/Y = \alpha (W/Y) + \beta$$

- Because, in short periods, wealth does not vary proportionately with incomes, High incomes corresponds to Low APC.
- But over longer periods, wealth and incomes grow together, resulting in constant W/Y ratio and hence a constant APC

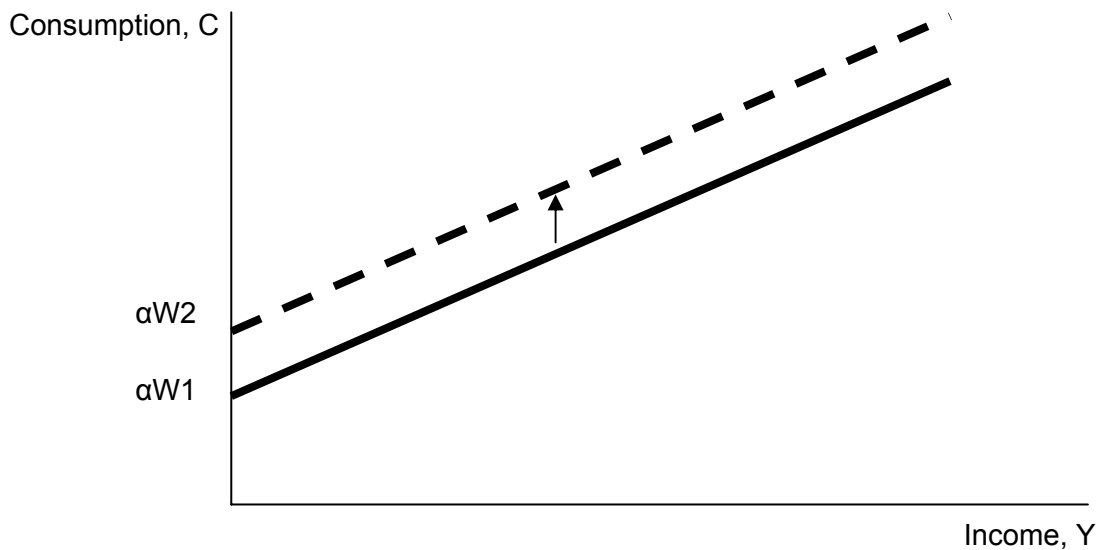

The Upward Shift prevents the APC from falling as income increases. Thus solving Keynes's puzzle

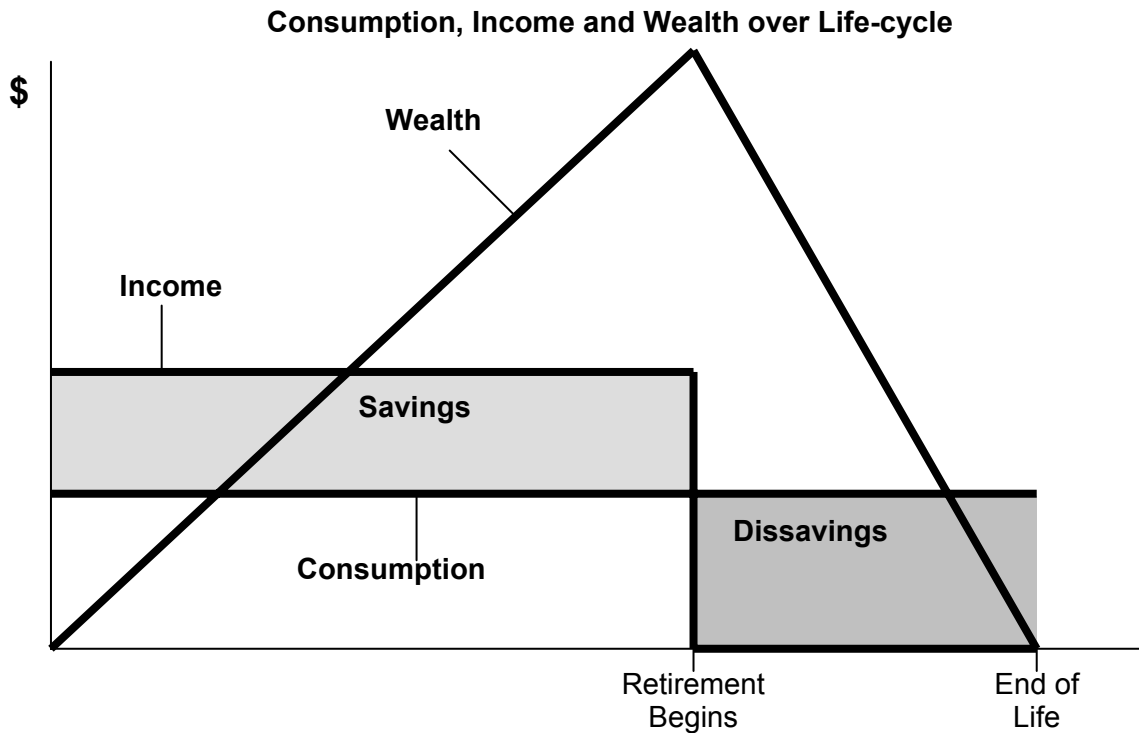

Consumption and Saving of Elderly

- Research findings show that elderly people do not dissave as much as the life cycle model predicts.
- In other words, the elderly do not run down their wealth as quickly as one would expect if they were trying to smooth their consumption over their remaining years of life.
- Reasons
 - They are concerned about unpredictable expenses. Additional saving that rises from uncertainty is called precautionary saving. This may be due to expecting a long life and to plan for a longer period of retirement.

- It is not completely persuasive considering the availability of annuity schemes of insurance companies and public health insurance plans.
- They may want to leave bequests to their children

Milton Friedman and the Permanent-Income Hypothesis

- In 1957, Milton Friedman proposed the permanent-income hypothesis to explain consumer behavior.
- Its essence is that current consumption is proportional to permanent income. Friedman's permanent-income hypothesis complements Modigliani's life-cycle hypothesis: both use Fisher's theory of the consumer to argue that consumption should not depend on current income alone.

But unlike the life-cycle hypothesis, which emphasizes that income follows a regular pattern over a person's lifetime, the permanent-income hypothesis emphasizes that people experience random and temporary changes in their incomes from year to year.

Friedman suggested that we view current income Y as the sum of two components, permanent income Y^P and transitory income Y^T .

$$Y = Y^P + Y^T$$

- Permanent Income is the part of income that people expect to persist in the future.
- Transitory income is the part of income that people do not expect to persist.
- Friedman reasoned that consumption should depend primarily on permanent income because consumers use savings and borrowings to smooth consumption in response to transitory changes in income.
- Friedman approximation of consumption function is:

$$C = \alpha Y^P$$

- While Average propensity to consume is:

$$APC = C/Y = \alpha Y^P / Y$$

- When $Y > Y^P$, APC Falls
- When $Y < Y^P$, APC rises

Robert Hall and the Random-Walk Hypothesis

Robert Hall was first to derive the implications of rational expectations for consumption. He showed that if the permanent-income hypothesis is correct and if consumers have rational expectations, then changes in consumption over time should be unpredictable. When changes in a variable are unpredictable, the variable is said to follow a **random walk**.

According to Hall, the combination of the permanent-income hypothesis and rational expectations implies that consumption follows a random walk.

LESSON 40

INVESTMENT

- Investment is the most volatile component of GDP. When expenditure on goods and services fall during a recession, much of the decline is usually due to a drop in investment spending.
- Economists study investment to better understand the fluctuations in the economy's output of goods and services.
- The models of GDP, such as IS-LM model, were based on a simple investment function relating investment to real interest rate: $I = I(r)$
- That function states that an increase in the real interest rate reduces Investment.
- Here we look more closely at the theory behind this investment function.

Three types of Investment Spending

- We shall build models of each type of investment to explain the fluctuations in the economy. Also these models will shed light on the questions such as:
 - Why is investment negatively related to the interest rate?
 - What causes investment function to shift?
 - Why does investment rise during booms and fall during recessions?

Business Fixed Investment

- The largest piece of investment spending (about $\frac{3}{4}$ of total) is business fixed investment
 - Business: these investment goods are bought by firms for use in future production.
 - Fixed: This spending is for capital that will stay put for a while (as opposed for inventory investment)
- Business Fixed investment includes everything from fax machines to factories, computers to company cars

The standard model of business fixed investment is called the **neoclassical model of investment**. It examines the benefits and costs of owning capital goods. Here are three variables that shift investment:

- 1) The marginal product of capital
 - 2) The interest rate
 - 3) Tax rules
- To develop the model, imagine that there are two kinds of firms:
 1. Production firms that produce goods and services using the capital that they rent
 2. Rental firms that make all the investments in the economy.
 In reality, however, most firms perform both functions

The Rental Price of Capital

- A typical production firm decides how much capital to rent by comparing the cost and benefit of each unit of capital.
- The firm rents Capital at a rental rate R and sells its output at a price P
- The real cost of a unit of capital to the production firm is R/P
- The real benefit of a unit of capital is the marginal product of capital, MPK (the extra output produced with one more unit of capital)
- MPK falls as the amount of capital rises

- So, to maximize profit, the firm rents capital until the MPK falls to:

$$\text{MPK} = R/P$$

- Hence MPK determines the downward sloping demand curve for capital for a firm
- While at point in time, the amount of capital in an economy is fixed, so supply curve is fixed
- The real rental price of capital adjusts to equilibrate the demand for capital and the fixed supply.

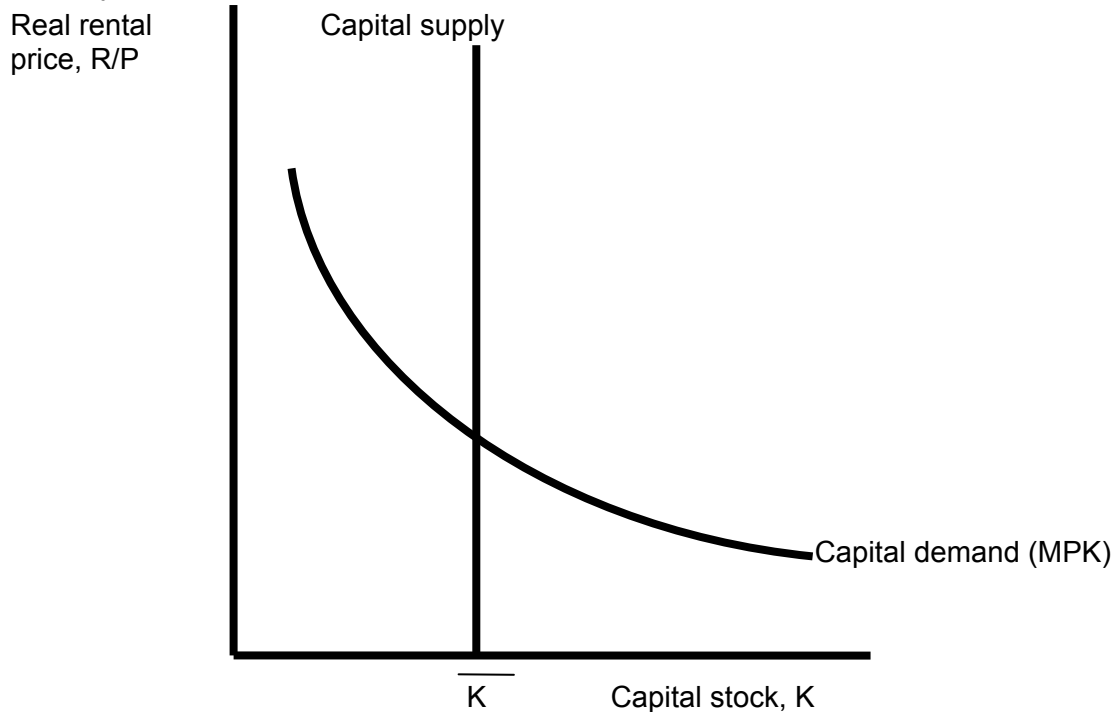

- The Cobb-Douglas production function serves as a good approximation of how the actual economy turns capital and labor into goods and services.
- The Cobb-Douglas production function is:

$$Y = AK^\alpha L^{1-\alpha}$$

Where

$Y \Rightarrow$ is output

$K \Rightarrow$ capital

$L \Rightarrow$ labor

$A \Rightarrow$ a parameter measuring the level of technology

$\alpha \Rightarrow$ a parameter between 0 and 1 that measures capital's share of output.

- The marginal product of capital (MPK) for the Cobb-Douglas production function is:

$$\text{MPK} = \alpha A (L/K)^{1-\alpha}$$
- Because the real rental price (R/P) equals MPK in equilibrium, we can write:

$$R/P = \alpha A (L/K)^{1-\alpha}$$
- This expression identifies the variables that determine the real rental price.

It shows the following:

- The lower the stock of capital, the higher the real rental price of capital
- The greater the amount of labor employed, the higher the real rental price of capitals
- The better the technology, the higher the real rental price of capital.

Events that reduce the capital stock, or raise employment, or improve the technology, raise the equilibrium real rental price of capital.

The Cost of Capital

- The Rental firms, just like car rental firms merely buy capital goods and rent them out.
- Let's consider the benefit and cost of owning capital.
 - The benefit of owning capital is the real rental price of capital R/P for each unit of capital it owns and rents out.

For each period of time that a firm rents out a unit of capital, the rental firm bears three costs:

1. Interest on their loans, which equals the purchase price of a unit of capital P_K times the interest rate, i , so iP_K
 2. The cost of the loss or gain on the price of capital denoted as $-\Delta P_K$
 3. **Depreciation** δ defined as the fraction of value lost per period because of the wear and tear, so δP_K
- Therefore,

$$\text{Total cost of capital} = iP_K - \Delta P_K + \delta P_K$$

Or

$$= P_K (i - \Delta P_K/P_K + \delta)$$

The cost of capital depends upon the price of capital, the interest rate, rate of change of capital prices and the depreciation rate.

- Example: A Car rental company
 - Buys cars for Rs.1, 000,000 each and rents them out to other businesses
 - If it faces an interest rate i of 10% p.a. so the interest cost, $iP_K = \text{Rs.}100, 000$ p.a.
 - Car prices are rising @ 6% per year, so excluding maintenance costs the firm gets a capital gain, $\Delta P_K = \text{Rs.}60,000$ p.a
 - Cars depreciate @ 20% p.a. so loss due to wear and tear, $\delta P_K = \text{Rs.}200, 000$
- So,

$$\begin{aligned} \text{Total cost of capital} &= iP_K - \Delta P_K + \delta P_K \\ &= 100,000 - 60,000 + 200,000 \\ &= \text{Rs.}240, 000 \end{aligned}$$

Summary

- Investment
 - Business Fixed Investment
 - Rental Price of Capital
 - Cost of Capital

INVESTMENT (Continued...)

The Cost of Capital

Total cost of capital = $iP_K - \Delta P_K + \delta P_K$

$$= P_K (i - \Delta P_K/P_K + \delta)$$

The cost of capital depends upon the price of capital, the interest rate, rate of change of capital prices and the depreciation rate.

- Assuming price of capital goods rises with the prices of other goods, so

$$\Delta P_K/P_K = \text{overall inflation rate, } \pi$$

Since,

$$r = i - \pi,$$

$$\text{Cost of Capital} = P_K(r + \delta)$$

- To express the cost of capital relative to other goods in the economy.
- The real cost of capital-- the cost of buying and renting out a unit of capital measured in terms of the economy's output is:

$$\text{Real Cost of Capital} = (P_K / P) (r + \delta)$$

Where

$r \Rightarrow$ the real interest rate

$P_K / P \Rightarrow$ the relative price of capital.

The Determinants of Investment

- Now consider a rental firm's decision about whether to increase or decrease its capital stock. For each unit of capital, the firm earns real revenue R/P and bears the real cost $(P_K / P) (r + \delta)$.
- The real profit per unit of capital is

$$\text{Profit rate} = \text{Revenue} - \text{Cost}$$

$$= R/P - (P_K / P) (r + \delta).$$

- Because real rental price equals the marginal product of capital, we can write the profit rate as

$$\text{Profit rate} = \text{MPK} - (P_K / P) (r + \delta)$$

- The change in the capital stock, called net investment depends on the difference between the MPK and the cost of capital.
 - If the MPK exceeds the cost of capital, firms will add to their capital stock.

– If the MPK falls short of the cost of capital, they let their capital stock shrink.

– Thus:

$$\Delta K = I_n [\text{MPK} - (\text{PK} / \text{P})(r + \delta)]$$

– Where $I_n ()$ is the function showing how much net investment responds to the incentive to invest.

The Investment Function

• We can now derive the investment function in the neoclassical model of investment. Total spending on business fixed investment is the sum of net investment and the replacement of depreciated capital.

• The investment function is:

$$I = I_n [\text{MPK} - (\text{PK} / \text{P})(r + \delta)] + \delta K$$

• This model shows why investment depends on the real interest rate.

• A decrease in the real interest rate lowers the cost of capital. It therefore raises the amount of profit from owning the capital and increases the incentive to accumulate more capital.

• Similarly an increase in real interest rate raises cost of capital and leads the firms to reduce their investment.

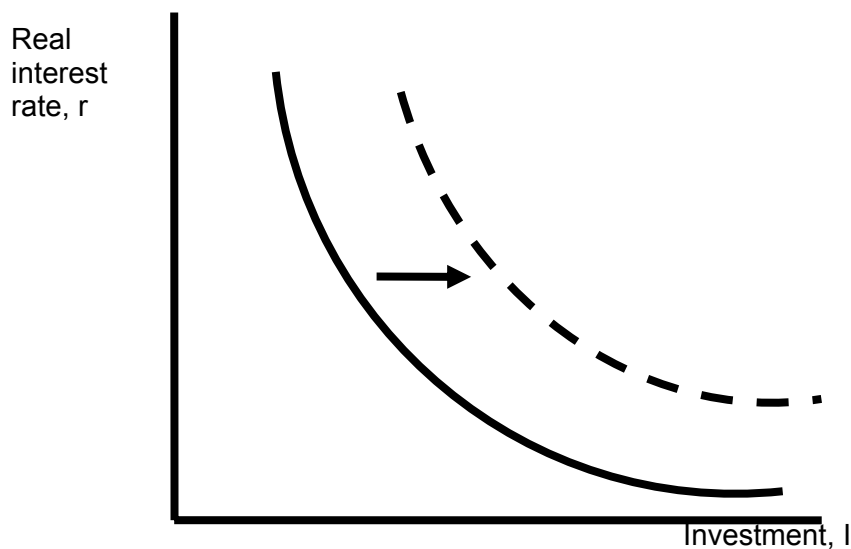

$I \uparrow$ as $r \downarrow$, hence the downward slope of the investment function. Also, an outward shift in the investment function may be a result of an increase in the marginal product of capital. e.g. a technological innovation

- Finally, we consider what happens as this adjustment of the capital stock continues over time.
 - If the marginal product begins above the cost of capital, the capital stock will rise and the marginal product will fall.
 - If the marginal product of capital begins below the cost of capital, the capital stock will fall and the marginal product will rise.
- Eventually, as the capital stock adjusts, the MPK approaches the cost of capital.
- When the capital stock reaches a steady state level, we can write:

$$MPK = (PK / P) (r + \delta)$$

- Thus, in the long run, the MPK equals the real cost of capital. The speed of adjustment toward the steady state depends on how quickly firms adjust their capital stock, which in turn depends on how costly it is to build, deliver and install new capital.

Taxes and Investment

- Tax laws influence the firms' incentives to accumulate the capital in many ways.
- Sometimes policymakers change the tax laws in order to shift the investment function and influence aggregate demand.
- Here we discuss two of the most important provisions of corporate taxes:
 - Corporate Income Tax
 - Investment Tax Credit
- Corporate income tax is a tax on corporate profits, and its effect on investment depends on how the law defines profit for the purpose of taxation.
- Suppose, at first, the law says:

$$\text{Profit rate} = R/P - (PK / P) (r + \delta)$$

- In this case, even though firms would be sharing a fraction of their income with the government, it would still be rational for them to invest if

$$R/P > (PK / P) (r + \delta)$$

- But in reality the definition of law is quite different than this.
 - Treatment of depreciation
 - Theoretically: current value of depreciation
 - Tax laws: depreciation at historical cost
- The Investment Tax Credit is a tax provision that encourages the accumulation of capital. It reduces a firm's taxes by a certain amount for each unit of money spent on capital goods.
- Since the firm recoups part of its expenditures on new capital in lower taxes, the credit reduces the effective purchase price of a unit of capital P_k . Thus reducing the cost of capital and raising investment.

Swedish Investment Funds System

- Tax incentives for investment are one tool policy makers can use to control aggregate demand.
- For example, an increase in the investment tax credit reduces the cost of capital, shifts investment function upward, and raises the aggregate demand.
- From mid-50s to mid-70s the govt. of Sweden attempted to control aggregate demand by encouraging or discouraging investment, through a system called Investment Fund subsidized investment
- In case of economic slowdown, the authorities offered a temporary investment subsidy, and in case of economic recovery, revoked it.
- Eventually subsidy became a permanent feature of Swedish tax policy.

INVESTMENT (Continued...)

The Stock Market and Tobin's q

- The term stock refers to the shares in the ownership of corporations
- Stock market is the market in which these shares are traded.
- The Nobel-Prize-winning economist James Tobin proposed that firms base their investment decisions on the following ratio, which is now called **Tobin's q**:

$$q = \frac{\text{Market Value of Installed Capital}}{\text{Replacement Cost of Installed Capital}}$$

- The numerator of Tobin's q is the value of the economy's capital as determined by the stock market. The denominator is the price of capital as if it were purchased today.
- Tobin conveyed that net investment should depend on whether q is greater or less than 1.
 - If $q > 1$, then firms can raise the value of their stock by increasing capital,
 - if $q < 1$, the stock market values capital at less than its replacement cost and thus, firms will not replace their capital stock as it wears out.
- Tobin's q and neo-classical model are closely related, since Tobin's q measures the expected future profitability as well as the current profitability.
- If the MPK exceeds cost of capital, the firms are earning profits on their installed capital, making rental firms desirable to own, raising market value of stocks of such firms, implying a high value of q

The Stock market as an Economic Indicator

- Although the volatility of stock market can give false signals about the future of economy, yet one should not ignore the link between the two.
- Changes in stock market often reflect changes in GDP. whenever stock market experiences a substantial decline, we should be ready for an upcoming recession.
- Why do stock prices and economic activity tend to fluctuate together?
- Tobin's q and AD-AS Model
 - Suppose there occurs a fall in stock prices. Since replacement cost of capital is stable, this will result in a fall in Tobin's q, reflecting investors' pessimism about the current or future profitability of capital.
- Some Additional Reasons
 - A fall in stock prices makes people poorer, depressing their spending, resulting in reduced aggregate demand
 - Fall in stock prices reflect bad news about technological progress and economic growth, resulting in slow expansion of natural rate of output.

Financing Constraints

- When a firm wants to invest in new capital, e.g. by building a new factory, it raises the funds in financial markets by
 - Obtaining loans from banks
 - Selling bonds to public
 - Selling shares in future profits on stock market
- Neo classical model assumes that if a firm is willing to pay cost of capital, financial markets will make the funds available.

- But sometimes firms face Financing constraints, limiting the amount of funds they can raise from financial market.
- So the amount a firm can spend on new capital goods is limited to the amount it is currently earning.
- For example, a recession reduces employment, rental price of capital and profits. If the firm expects the recession to be short lived, it will continue investing for long term profitability, thus having a small effect on Tobin's q .
- So the firm that can raise funds in financial markets will face a small effect of recession on the investment.
- While incase of firms facing constraints, the fall in current profits restrict the spending on new capital goods and may prevent such firms from making profitable investment.

Residential Investment

We will now consider the determinants of residential investment by looking at a simple model of the housing market. Residential investment includes the purchase of new housing both by people who plan to live in it themselves and by landlords who plan to rent it to others.

To keep things simple, we shall assume that all housing is owner-occupied.

There are two parts to the model:

- 1) The market for the existing stock of houses determines the equilibrium housing price
 - 2) The housing price determines the flow of residential investment.
- The relative price of housing adjusts to equilibrate supply and demand for the existing stock of housing capital.
 - Construction firms buy materials and hire labor to build the houses and then sell them at market price.
 - Their costs depend on the overall price level P while their revenue depends on the price of houses P_H .
 - The Higher the P_H , the greater incentive to build house.

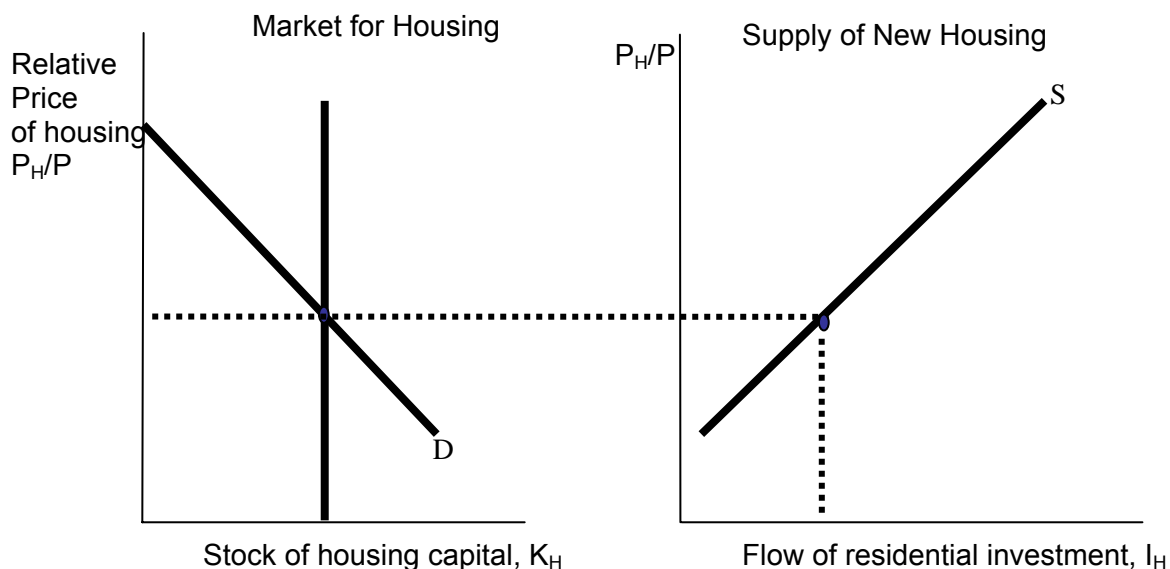

- This model of residential investment is much similar to q theory of business fixed investment, which states that business fixed investment depends on the market price of installed capital relative to its replacement cost, which in turn depends on expected profits from owning installed capital
- The residential investment depends on the relative price of housing, which in turn depends on demand for housing, depending on the imputed rent that individuals expect to receive from their housing

LESSON 43

INVESTMENT (Continued...)

Inventory Investment

- Inventory investment, the goods that businesses put aside in storage, is at the same time negligible and of great significance.
- It is one of the smallest components of spending, yet its volatility makes it critical in the study of economic fluctuations.
- In recession, firms stop replenishing their inventory as goods are sold, and inventory investment becomes negative.
 1. When sales are high, the firm produces less than it sells and it takes the goods out of inventory. This is called **production smoothing**.
 2. Holding inventory may allow firms to operate more efficiently. Thus, we can view **inventories as a factor of production**.
 3. Also, firms don't want to run out of goods when sales are unexpectedly high. This is called **stock-out avoidance**.
 4. Lastly, if a product is only partially completed, the components are still counted in inventory, and are called, **work in process**.

Seasonal Fluctuation and Production Smoothing

- Contrary to the expectations of many economists and researchers, firms do not use inventories to smooth production over time.
- The clearest evidence comes from industries with seasonal fluctuations in demand. e.g. fan manufacturing. One would expect that firms would build up inventories in times of low sales and draw them down in times of high sales.
- Yet in most industries firms do not use inventories to smooth production over the year, rather seasonal pattern matches seasonal pattern in sales.

The Accelerator Model of Inventories

The **accelerator model** assumes that firms hold a stock of inventories that is proportional to the firm's level of output.

When output is high, manufacturing firms need more materials and supplies on hand, and more goods in process of completion.

When Economy is booming, retail firms want to have more merchandise on their shelves to show customers.

- Thus, if N is the economy's stock of inventories and Y is output, then

$$N = \beta Y$$

where β is a parameter reflecting how much inventory firms wish to hold as a proportion of output.

- Inventory investment I is the change in the stock of inventories $\beta \Delta Y$.
- Therefore,

$$I = \Delta N = \beta \Delta Y$$

The accelerator model predicts that inventory investment is proportional to the change in output

- When output rises, firms want to hold a larger stock of inventory, so inventory investment is high
- When output falls, firms want to hold a smaller stock of inventory, so they allow their inventory to run down, and inventory investment is negative.

The model says that inventory investment depends on whether the economy is speeding up or slowing down.

Inventories and the Real Interest Rate

- Like other components of investment, inventory investment depends on the real interest rate.
- When a firm holds a good in inventory and sells it tomorrow rather than selling it today, it gives up the interest it could have earned between today and tomorrow.
- Thus, the real interest rate measures the opportunity cost of holding inventories.
- When the interest rate rises, holding inventories becomes more costly, so rational firms try to reduce their stock.
- Therefore, an increase in the real interest rate depresses inventory investment.

LESSON 44

MONEY

Money Supply

- Earlier, we introduced the concept of money supply in a highly simplified way.
- We defined quantity of money as the number of rupees held by public, and assumed that central bank controls the supply of money by increasing or decreasing the number of rupees in circulation through open-market operations.
- Although a good approximation, this definition omits the role of banking system in determining the money supply.
- Here, we'll see that the money supply is determined not only by the Central Bank, but also by the behavior of households (which hold money) and banks (where money is held).
- Recall, the Money supply includes both currency in the hand of public and deposits at banks that households use on demand for transactions.

$$M = C + D$$

Where

M ---> Money Supply

C ---> Currency

D ---> Demand Deposits

100% Reserve Banking

- Imagine a world without banks, where all the money takes the form of currency, and the quantity of money is simply the amount of currency that public holds (assume \$1,000).
- Now a new bank comes in and accepts deposits but does not make loans. Its only purpose is to provide a safe place for depositors to keep money

The deposits that banks have received but have not lent out are called reserves.

Some Reserves are held in the vaults of local banks but most are held at the central bank.

Consider the case where all deposits are held as reserves: banks accept deposits, place the money in reserve, and leave the money there until the depositor makes a withdrawal or writes a check against the balance.

In a 100% reserve banking system, all deposits are held in reserve and thus the banking system does not affect the supply of money.

- Suppose that households deposit the economy's entire \$1,000 in First bank. This bank's balance sheet will look like:

Assets		Liabilities	
Reserves	\$1,000	Deposits	\$1,000

- The bank is not making loans so it is not earning profit rather a small fee to cover its cost.
- The money supply in the economy before and after the creation of bank remains the same, i.e. \$1,000. So 100% reserve deposit does not affect money supply in economy

Fractional Reserve Banking

- Now, if the banks start to use some of their deposits to make loans (e.g. to households for house finance and to firms for capital finance), they can charge interest on the loans.

- The banks must keep some reserve on hand so that reserves are available whenever depositors want to make withdrawals.
- As long as the amount of new deposits approximately equals the amount of withdrawals, a bank need not keep all its deposits in reserves.
- Note: a *reserve-deposit ratio* is the fraction of deposits kept in reserve. **Excess reserves** are reserves above the reserve requirement.
- **Fractional-reserve banking**, a system under which banks keep only a fraction of their deposits in reserve. In a system of fractional reserve banking, banks create money.

LESSON 45

MONEY (Continued...)**How does the Central Bank control the money supply?**

- 1) Open Market Operations
- 2) Changing the Reserve Requirements
- 3) Changing Discount rate

Three Instruments of Money Supply

- Open market operations are the purchase and sale of government bonds by the central bank.
 - When the central bank buys bonds from public, the money it pays for the bonds increases the monetary base and thus increase the money supply
 - When the central bank sells the bonds to the public, the money it receives reduces monetary base and hence reduce money supply
- Reserve requirements are central banks regulations that impose on banks a minimum reserve-deposit ratio.
 - An increase in reserve requirements raises reserve deposit ratio and thus lowers the money multiplier and the money supply
- The Discount rate is the interest rates that central bank charges when it lends to the banks.
- Banks borrow from central bank when they find themselves with too few reserves to meet reserve requirements. The lower the discount rate, the cheaper are borrowed reserves and more demands for such loans
- Hence a reduction in discount rate raises the monetary base and the money supply.
- Although these instrument give central bank substantial power to influence the the money supply, yet it can't do it perfectly. Bank discretion in conditioning business can cause the money supply to change the way central bank did not anticipate.
 - Excessive Reserves
 - No limit on the amount of bank borrowings from discount window

Money Demand**Classical Theory of Money Demand**

- The Quantity Theory of Money assumes that the demand for real money balances is directly proportional to income,

$$(M/P) d = kY$$

- Where k is a constant measuring how much people want to hold for every dollar of income.

Keynesian Theory of Money Demand

- It presents a more realistic money demand function where the demand for real money balances depends on i and Y:

$$(M/P) d = L(i, Y)$$

- Recall, that money serves three functions

1. Unit of Account
 2. A store of value
 3. A medium of Exchange
- The first function can not by itself generate any demand for money, because we can quote prices in any currency without holding any amount of it. So we shall focus on the rest of the two functions as we look at theories of money demand

Portfolio Theories of Money Demand

- Theories of money demand that emphasize the role of money as a store of value are called portfolio theories. According to these theories, people hold money as part of their portfolio of assets.
- The key point is that money offers a different combination of risk and return than other assets, particularly a safe return (nominal). While other assets may fall in both real and nominal terms.
- These theories predict that demand for money should depend on the risk and return offered by money and other assets.
- Also money demand should depend on total wealth, because wealth measures the size of portfolio to be allocated among money and other assets.
- So we may write the money demand function as

$$(M/P)^d = L(r_s, r_b, \pi^e, W)$$

Where

- r_s = expected real return on stock
- r_b = expected real return on bonds
- π^e = expected inflation rate
- W = real wealth
- If r_s or r_b rises, money demand reduces, because other assets become more attractive
- A rise in π^e also reduces the money demand because money becomes less attractive
- An increase in W raises money demand because higher wealth means higher portfolio.
- Money Demand Function $L(i, Y)$: A useful simplification:
 - Uses real income Y as proxy for real wealth W
 - Nominal interest rate $i = r_b + \pi^e$
- Are these theories useful for studying money demand?
- The answer depends on which measure of money are we using.

<u>Symbol</u>	<u>Assets included</u>
C	Currency
M1	C + demand deposits, travelers' checks, other checkable deposits
M2	M1 + small time deposits, savings deposits, money market mutual funds, money market deposit accounts
M3	M2 + large time deposits, repurchase agreements, institutional money market mutual fund balances

- Economists say that M1 is a dominated asset: as a store of value, it exists alongside other assets that are always better.
- Thus it is not optimal for people to hold money as part of their portfolio and portfolio theories cannot explain the demand for these dominated forms of money
- But these theories would be more plausible if we adopt a broader measure of money like M2.

Transactions Theories of Money Demand

- Theories which emphasize the role money as a medium of exchange acknowledge that money is a dominated assets and stress that people hold money, unlike other assets, to make purchases.
- These theories best explain why people hold narrow measure of money as opposed to holding assets that dominate them.
- These theories take many forms depending on how one models the process of obtaining money and making transactions assuming
 - Money has the cost of earning a low rate of return
 - Money makes transactions more convenient
- One prominent model to explain the money demand function is Baumol-Tobin Model developed in 1950.

Baumol-Tobin Model of Cash Management

- This model analyzes the cost and benefits of holding money.
 - Benefit: Convenience (much less trips to banks)
 - Costs: foregone interest on money had it been deposited in a savings account
- Example:
 - A person plans to spend Y dollars over the course of an year (assuming constant price levels and real spending). What should be the optimal size of cash balances for him?
- Possibilities
 - Withdraw Y dollars at the beginning of the year and gradually spend the money balance averaging $Y/2$ over the year
 - Draw $Y/2$ at the beginning of year, spend it in six months then draw the rest $Y/2$ to be spent in next $\frac{1}{2}$ year. Average balance = $Y/4$
 - Generalizing: money holding vary between Y/N and zero, averaging $Y/(2N)$, where N is the number of trips to bank

- One implication of the Baumol-Tobin model is that any change in the fixed cost of going to the bank F alters the money demand function-- that is, it changes the quantity of money demanded for a given interest rate and income.

A Closer Look at Money Creation

Assume each bank maintains a *reserve-deposit ratio (rr)* of 20% and that the initial deposit is \$1000.

First bank Balance Sheet	
Assets	Liabilities
Reserve \$200 Loans \$800	Deposits \$1,000

Second bank Balance Sheet	
Assets	Liabilities
Reserve \$160 Loans \$640	Deposits \$800

Third bank Balance Sheet	
Assets	Liabilities
Reserve \$128 Loans \$512	Deposits \$640

Mathematically, the amount of money the original \$1000 deposit creates is:

Original Deposit	= \$1000
First bank Lending	= (1-rr) × \$1000
Second bank Lending	= (1-rr) ² × \$1000
Third bank Lending	= (1-rr) ³ × \$1000
Fourth bank Lending	= (1-rr) ⁴ × \$1000
	⋮
	⋮

Total Money Supply	= [1 + (1-rr) + (1-rr) ² + (1-rr) ³ + ...] × \$1000
	= (1/rr) × \$1000
	= (1/.2) × \$1000
	= \$5000

- The banking system’s ability to create money is the primary difference between banks and other financial institutions.
- Financial markets have the important function of transferring the economy’s resources from households (who wish to save some of their income for the future) to those households and firms that wish to borrow to buy investment goods to be used in future production
- The process of transferring funds from savers to borrowers is called financial intermediation.

A model of Money supply

- Three exogenous variables:
 - The **monetary base B** is the total number of dollars held by the public as currency C and by the banks as reserves R .
 - The **reserve-deposit ratio rr** is the fraction of deposits D that banks hold in reserve R .
 - The **currency-deposit ratio cr** is the amount of currency C people hold as a fraction of their holdings of demand deposits D .

Definitions of money supply and monetary base:

$$M = C + D$$

$$B = C + R$$

Solving for M as a function of 3 exogenous variables:

$$M/B = \frac{C/D + 1}{C/D + R/D}$$

Making substitutions for the fractions above, we obtain:

$$M = \frac{cr + 1}{cr + rr} \times B$$

Lets call this money multiplier, m

So

$$M = m \times B$$

Because the monetary base has a multiplied effect on the money supply, the monetary base is sometimes called *high-powered money*.

• An Example

- Suppose, monetary base B is \$500 billion, the reserve deposit ratio rr is 0.1 and currency deposit ratio cr is 0.6
- The money multiplier is:

$$m = \frac{0.6 + 1}{0.6 + 0.1} = 2.3$$

- And the money supply is:

$$M = 2.3 \times \$ 500 \text{ billion} = \$1,150 \text{ billion}$$

Let's go back to our three exogenous variables to see how their changes cause the money supply to change:

1. The money supply M is proportional to the monetary base B. So, an increase in the monetary base increases the money supply by the same percentage.
2. The lower the reserve-deposit ratio rr (R/D), the more loans banks make, and the more money banks create from every dollar of reserves.
3. The lower the currency-deposit ratio cr (C/D), the fewer dollars of the monetary base the public holds as currency, the more base dollars banks hold in reserves, and the more money banks can create. Thus a decrease in the currency-deposit ratio raises the money multiplier and the money supply.